

Amphenol Charles Industries' CUBE sectionalizer cabinets are designed to provide robust protection for underground distribution systems deployed in outdoor environments. These cabinets are built to withstand the harshest environments while providing safe and reliable protection for your equipment. Fabricated from high-quality, corrosion-resistant metal, our cabinets feature a sectionalized design that allows for easy installation and maintenance. The door is safeguarded with a locking mechanism to ensure that your equipment is secure.



CUBE Sectionalizer Cabinet

MARKETS SERVED:

- Telecom / FTTX
- Utility
- Wireless
- Broadband Cable

FEATURES

- Constructed of durable 14 gauge mild steel with a powder-coated finish that resists chipping, cracking, and fading
- Provides a low-cost, safe means of sectionalizing and tap point for underground distribution systems
- Available for use on single and three-phase systems rated 15kV through 35kV, in 200A or 600A
- Mounting plates with parking stands, light gray in color for visibility contrast
- Secure padlock locking mechanism resists prying
- Included with a wind stop for technician safety
- Available in 5 different sizes
- Meets ANSI C57.12.28 standards

Product Dimensions

All dimensions are in inches

CUBE TPC303622

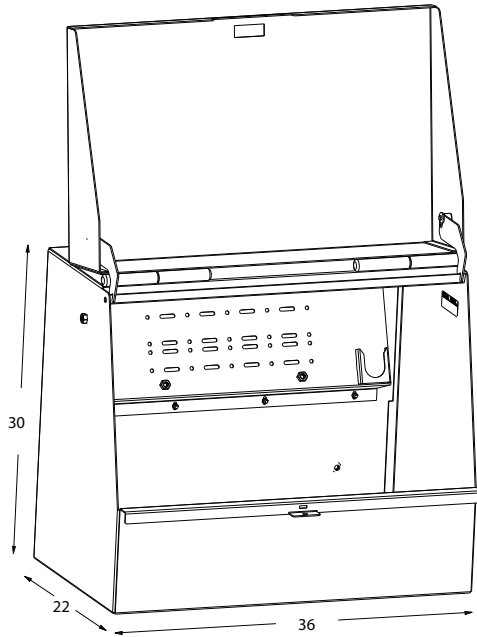

CUBE TPC306622

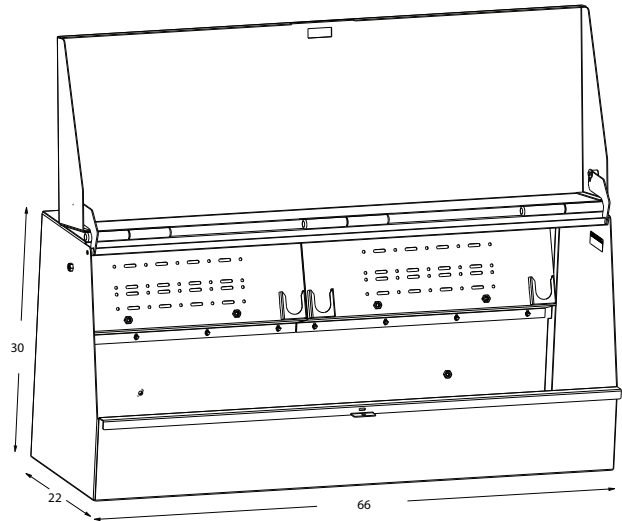

CUBE TPC308422

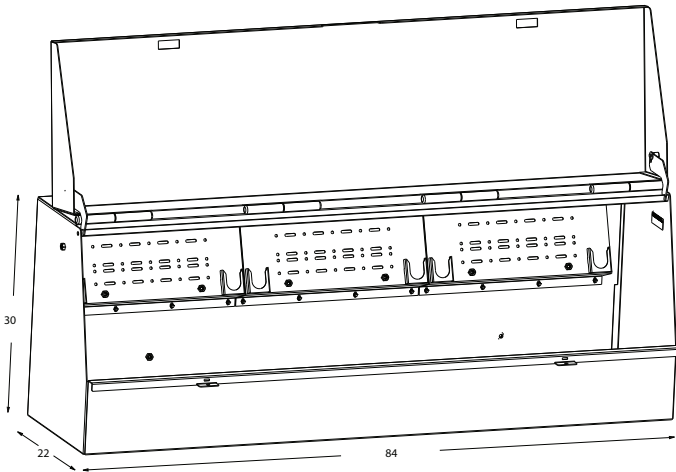

CUBE TPC308430

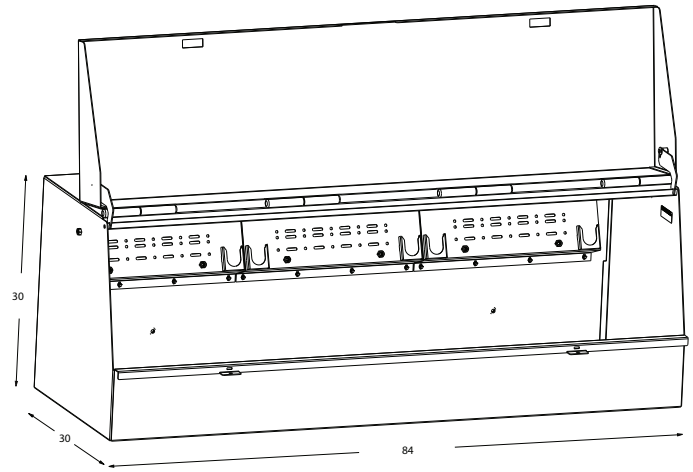

CUBE TPC309622

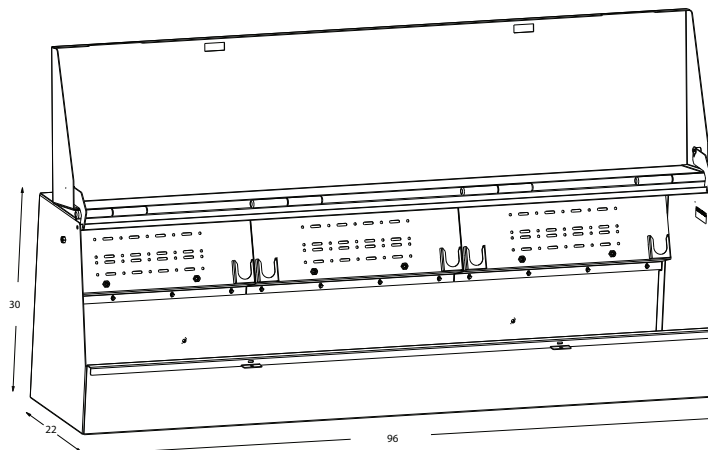

Part Numbers

Part Number	Description
CUBE-TPC303622	30"x36"x22" Enclosure, pad lock, dark green
CUBE-TPC306622	30"x66"x22" Enclosure, pad lock, dark green
CUBE-TPC308422	30"x84"x22" Enclosure, pad lock, dark green
CUBE-TPC308430	30"x84"x30" Enclosure, pad lock, dark green
CUBE-TPC309622	30"x96"x22" Enclosure, pad lock, dark green

Product Photos



Charles Industries, LLC

An Amphenol Company

1450 American Lane, 20th Floor, Schaumburg, IL 60173

 mktserv@charlesindustries.com

 (847) 806-6300

