

# AT&T Mobility Approved IS-48 Indoor/Outdoor Security Shrouds



Charles IS-48 security shrouds provide an aesthetic and effective method of protecting in-building wireless, DAS, and small cell radio equipment in venue installations. There are models that can be used to cover existing equipment on a wall or backboard and enclosed models with integrated backboards for new installations. They feature a slanted top to prevent placing unwanted objects. The units come with a variety of knockouts and openings for easy cable ingress and egress. Integrated bonding and grounding is included. Optional AC load centers and integrated fiber terminals are available. Some models are configured with brackets to mount common remote radio heads.

## Use Cases

- Stadiums and arenas
- Theatres
- Parking garages
- Airports
- Premises telecom rooms

Prepared for



February 2021

## Specifications

Wall footprint	.48" x 48" (units can be joined to cover 96" space)	
Depth Options	.14 inch or 20 inch	
Material	.0.125 welded Aluminum	<b>MADE IN THE USA</b>
Colors	.Powder coated Off-white, Gray or Black	
Ambient temp range	-.40° to +115° F/-40° to +46° C	
Operating temp range (inside enclosure)	-.40° to +149° F/-40° to +65° C	
Bonding and grounding	.(2) 2x8 position ground bars; (4) pairs of external ground studs	
Cable entries.	Varies by model	

# AT&T Mobility Approved IS-48 Concealment Shroud Covers

IS-48 "0" series is an aesthetic shroud cover which conceals and protects equipment that is already installed and mounted on a wall. The shrouds cover a commonly used 48 x 48 inch footprint. The shrouds have 3 pass-through knockouts on each end so units can be joined to conceal and protect a larger backboard up to 96 inches. IS-48 units are available in depths of 14 or 20 inches and in a number of colors.

Charles Part Number	CEQ Number	Wall Footprint	Depth	Mounting	Color	Approx. Weight	Ship Qty. Per Pallet	Configuration*
IS-4814481A0GNN	52019	48" x 48"	14"	Wall	Off-white	59 lb.	2	Empty shroud cover
IS-4814481D0GNN	52035	48" x 48"	14"	Wall	Gray	59 lb.	2	Empty shroud cover
IS-4814481F0GNN	52028	48" x 48"	14"	Wall	Black	59 lb.	2	Empty shroud cover
IS-4820481A0GNN	52030	48" x 48"	20"	Wall	Off-white	67 lb.	2	Empty shroud cover
IS-4820481D0GNN	52029	48" x 48"	20"	Wall	Gray	67 lb.	2	Empty shroud cover
IS-4820481F0GNN	52025	48" x 48"	20"	Wall	Black	67 lb.	2	Empty shroud cover

\* For customized sizes or configurations, please consult your Charles salesperson for further details or call (847) 806-6300.

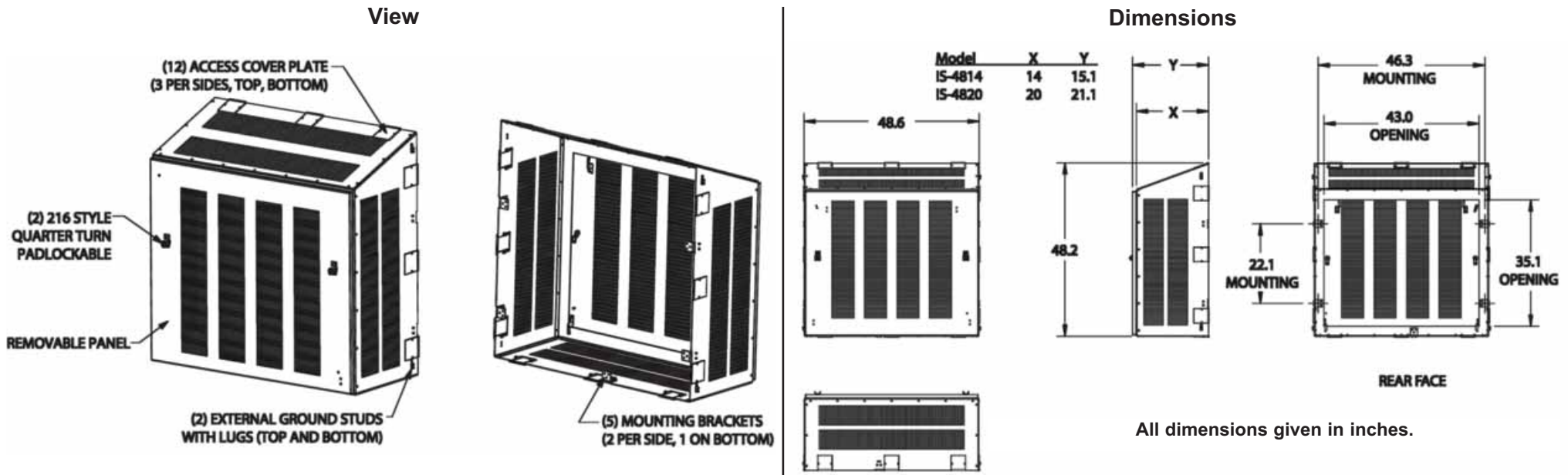

# AT&T Mobility Approved

## IS-48 Concealment Shroud Enclosures

IS-48 units are available as aesthetic shroud enclosures to install, conceal, and protect in building wireless radio equipment. These shrouds have a wall mounted footprint of 48 x 48 inches and come in depths of 14 or 20 inches. A number of power options and fiber terminals can be factory installed. Bracketry to mount common remote radio heads is also available. Please contact Charles with your specific requirements.

Charles Part Number	CEQ Number	Wall Footprint	Depth	Mounting	Color	Approx. Weight	Ship Qty. Per Pallet	Configuration*
IS-4814481ANGNN	52021	48" x 48"	14"	Wall	Off-white	100 lb.	2	Empty Enclosure
IS-4814481DNGNN	52022	48" x 48"	14"	Wall	Gray	100 lb.	2	Empty Enclosure
IS-4814481FNGNN	52020	48" x 48"	14"	Wall	Black	100 lb.	2	Empty Enclosure
IS-4820481ANGNN	52023	48" x 48"	20"	Wall	Off-white	110 lb.	2	Empty enclosure
IS-4820481DNGNN	52027	48" x 48"	20"	Wall	Gray	110 lb.	2	Empty enclosure
IS-4820481FNGNN	52024	48" x 48"	20"	Wall	Black	110 lb.	2	Empty enclosure

\* For customized sizes, configurations and other colors, please consult your Charles salesperson for further details or call (847) 806-6300.

**View (IS-4820481XNGNN)**

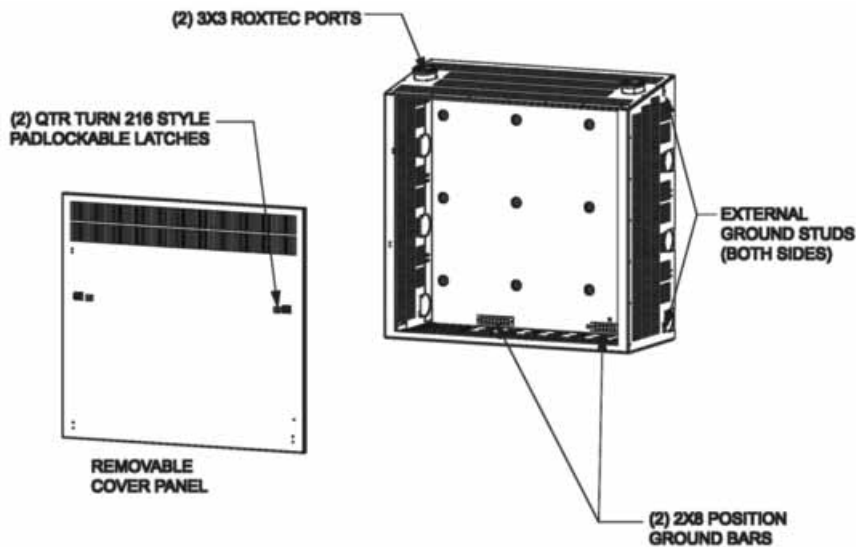

**Dimensions (IS-4820481XNGNN)**

