

Engineering Guidelines for the *AdrenaLine*™ Series of OSP xDSL Single-Line Conditioners Powered by *Phylog*®

PART #	PAGE #
1. GENERAL	1
1.1 Document Purpose	1
1.2 Product Description	1
2. OSP PLANNING	2
2.1 Product Applications	2
2.2 Anticipated Product Performance	3
3. OSP ENGINEERING	5
3.1 Verifying Loop Requirements	5
3.3 Determining Product Placement	7
3.2 Selecting Specific Product	7
4. ADRENALINE INSTALLATION	7
4.1 Determining Mounting Type	8
4.2 Installing the Selected AdrenaLine Unit	9
4.3 Testing the Installation	10
5. OSP MAINTENANCE & TROUBLESHOOTING	10
6. TECHNICAL ASSISTANCE	10
7. WARRANTY	10
8. RETURNS AND REPLACEMENT	10
9. SPECIFICATIONS	10
9.2 Ordering Information	10
9.3 Trademark Information	11
9.4 Compliance Information	11
9.1 Electrical and Physical Specifications	10
9.5 Acronyms & Abbreviations	11
10. TROUBLESHOOTING	12

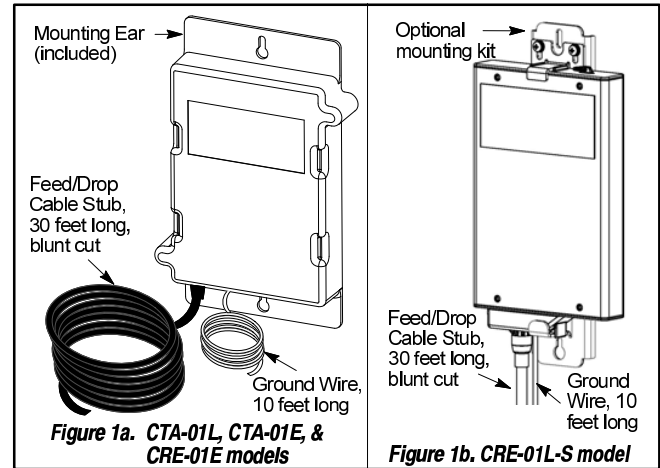

Figure 1. AdrenaLine xDSL Line Conditioner

- IMPORTANT NOTE -

For the most current, up-to-date, AdrenaLine documentation, always go to www.charlesindustries.com/main/adrenaline.html, or call the Charles Technical Support Group for assistance at 1-800-607-8500.

1. GENERAL

1.1 Document Purpose

This document provides general, planning, engineering, installation, maintenance, and technical specification information on the Charles Industries' AdrenaLine™ series of xDSL single-line conditioners for Outside Plant (OSP) applications. Figure 1 shows a single-line AdrenaLine unit. See Table 14 on Page 10 for specific model numbers in the series.

- NOTE -

Hereafter, all AdrenaLine xDSL Single-Line Conditioners may be referred to as the "AdrenaLine." Specific models or units will be specified where differences apply.

1.2 Product Description

The AdrenaLine xDSL Single-Line Conditioner is an analog device that improves available ADSL/ADSL2/ADSL2+ bandwidth through noise filtering and signal amplification. The line conditioner system employs Phylog® Inc.'s TripleStream® technology and is packaged in a hardened OSP enclosure system. The AdrenaLine xDSL Line Conditioner is placed at an approximate mid-point between the DSLAM equipment and customer premise equipment. AdrenaLine tunes its internal circuitry to compensate for distance, wire gauge and other plant variables,

and conditions the DSL line in both directions to maximize rate and reach. Minimal power is required, and negligible disturbance is imposed on adjacent pairs. Single line units are available in express or line power. Table 1 provides product specifications for express and line power.

Table 1. Single-line Unit Specifications

AdrenaLine Specifications (see also Table 8)
CO Voltage Requirement: -48 VDC
Minimum Input Voltage: -22 VDC when CPE is off-hook
Maximum Input Voltage: -56 VDC
Loop Polarity: Ring is negative with respect to Tip
Loop Current: 20 mA minimum at the CPE (within AdrenaLine placement guidelines)
Power Consumption: 250 mW maximum
C-Message Noise, dBmC, nominal: CTA-01L = 6, CTA-01E = 1, CRE-01E = 1.
Insertion Loss, dB, nominal: CTA-01L = 0.4, CTA-01E = 1.2, CRE-01E = 1.2.
CO Current, mA, minimum: CTA-01L = 35, CTA-01E = 10, CRE-01E = 10.
Tested and designed to the following industry standards
Bellcore SR-3580 NEBS Level 3 Requirements: <ul style="list-style-type: none"> ○ GR-1089-CORE, Electromagnetic Compatibility and Electrical Safety - Generic Criteria for Network Telecommunications Equipment ○ GR-63-CORE, NEBS Requirements: Physical Protection
Bellcore GR-78-CORE, Generic Requirements for the Physical Design and Manufacture of Telecommunications Products and Equipment
Bellcore GR-506-CORE: LATA Switching Systems Generic Requirements - Signaling for Analog Interfaces Switching
Bellcore TR-NWT-000057, Functional Criteria for Digital Loop Carrier Systems

Table 1 (Continued) - Single-line Unit Specifications

Bellcore TR-NWT-000335: Voice Grade Special Access Services - Transmission Parameter Limits and Interface Combinations
Bellcore TR-NWT-000393, Generic Requirements for Basic Access Digital Subscriber Lines
Bellcore TR-NWT-000507: LATA Switching Systems Generic Requirements - Transmission

Bellcore TR-TSY-000510: LATA Switching Systems Generic Requirements - System Interfaces
DSL Forum TR-067, ADSL Interoperability Test Plan, May 2004
EN 60950
ITU-T G.992.1 ADSL, Annex A (POTS) only
ITU-T G.992.3 ADSL2, Annex A (POTS) only
ITU-T G.992.5 ADSL2+, Annex A (POTS) only
ANSI T1.401: Interface Between Carriers and Customer Installations-Analog Voicegrade Switched Access Lines Using Loop-Start and Ground-Start Signaling
ANSI T1.413-1998 Annex E POTS Splitter Requirements
Ameritech AM TR-TMO-000122 Ameritech Unbundled Analog Loops Technical Specifications

Note: Only the applicable sections of the referenced specifications apply.

2. OSP PLANNING

To help determine whether AdrenaLine will fit into your network scheme or configuration, consider the typical DSL applications for AdrenaLine and the anticipated product performance and expectations, as described in this section and as illustrated in Table 3 through Table 7.

2.1 Product Applications

AdrenaLine boosts your existing DSL bandwidth for standards based ADSL/ADSL2/ADSL+. CTA models are optimized for shorter loops. CRE models are optimized for longer loops. See Table 8 for loop length guidelines.

The AdrenaLine CTA xDSL line conditioners improve data rates 30-100% for a given distance and improve reach 20-30% for a given data rate (see Table 2). The AdrenaLine CRE models improve data rates 80-300% for a given distance and improve reach 20-30% for a given data rate.

Table 2. Expected Performance Improvements

	Bandwidth	Reach
CTA	30-100%	20-30%
CRE	80-300%	20-30%

Note: Bandwidth improvements for the same reach, reach improvements for the same bandwidth.

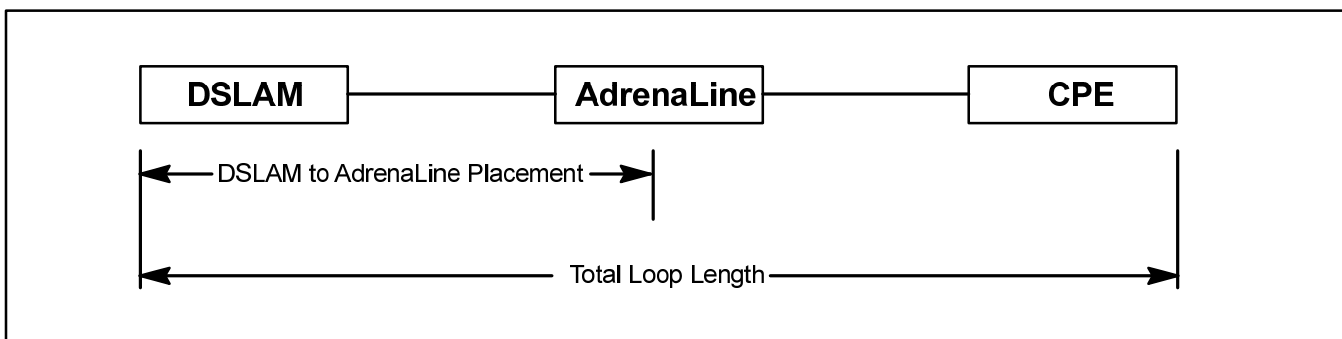

Figure 2. Typical AdrenaLine Application

2.1.1 ADSL2 and ADSL2+ Application

ADSL2+ applications include: voice, data and video (known as “Triple Play”). AdrenaLine is currently designed to be compatible with ADSL2/ADSL2+ DSLAMs. ADSL2+ is capable of supporting three simultaneous 3.8 Mbps video channels over maximum distances of up to 8,000 feet.

Three simultaneous 3.8 Mbps standard digital video channels with voice and data bandwidth requirements soon get into a fringe area of deployment beyond 5,000 feet of 26 AWG cable without either the use of AdrenaLine or extending the DSLAM closer to the customer.

2.1.2 ADSL Application

ADSL applications include voice and data, however, they could include a stand-alone data service offering. AdrenaLine is currently designed to be compatible with ADSL and ADSL2+ DSLAMs. An ADSL circuit connects an ADSL modem on each end of a twisted-pair copper telephone line, creating three information channels including a high speed downstream channel, a medium speed duplex channel, depending on the implementation of the ADSL architecture, and POTS (Plain Old Telephone Ser-

vice). The POTS channel is split off from the digital modem by filters, thus guaranteeing uninterrupted POTS even if ADSL fails. The high-speed channel ranges from 1.5 to 6.1 Mbps.

Downstream data rates depend on a number of factors, including the length of the copper line, its wire gauge, the presence of bridged taps, and cross-coupled interference. Line attenuation increases with line length and frequency, and decreases as wire diameter increases.

2.2 Anticipated Product Performance

The tables in Paragraphs 2.2.1 and 2.2.2 that follow contain downstream data rates measured in a lab environment using wire line simulators. Actual data rates in the Outside Plant (OSP) will be lower depending on the OSP network conditions where AdrenaLine is installed. Data rates will be lower when disturbers (e.g., ISDN, T1, HDSL2, HDSL4, and other ADSL signals) are present in the same cable.

2.2.1 ADSL2+ Performance Expectations

See Table 2 through Table 4 for ADSL2+ performance expectations.

Table 3. ADSL2+ Downstream Lab Performance Example (Without AdrenaLine Installed)

Total Loop Distance											
Kft 22 AWG	9.6	11.2	12.8	14.4	16.0	17.6	19.2	20.8	22.4	24.0	25.6
Kft 24 AWG	7.6	8.9	10.1	11.4	12.7	13.9	15.2	16.5	17.7	19.0	20.3
Kft 26 AWG	6.0	7.0	8.0	9.0	10.0	11.0	12.0	13.0	14.0	15.0	16.0
Downstream Rates Mbps											
	21.05	17.91	14.95	12.32	9.92	7.79	6.13	4.83	3.71	2.83	2.08
10 Kft 26 AWG loop length gives 9.92 Mbps											
14 Kft 26 AWG loop length gives 3.71 Mbps											

Table 4. ADSL2+ Downstream Lab Performance Example (With AdrenaLine CTA Installed)

Total Loop Distance													
Kft 22 AWG	9.6	11.2	12.8	14.4	16.0	17.6	19.2	20.8	22.4	24.0	25.6		
Kft 24 AWG	7.6	8.9	10.1	11.4	12.7	13.9	15.2	16.5	17.7	19.0	20.3		
Kft 26 AWG	6.0	7.0	8.0	9.0	10.0	11.0	12.0	13.0	14.0	15.0	16.0		
CO To AdrenaLine CTA Placement			Downstream Rates Mbps										
Kft 22 AWG	Kft 24 AWG	Kft 26 AWG											
4.8	3.8	3.0	23.27	22.72	19.90	16.45	12.23	9.59	7.26	5.81			
6.4	5.1	4.0	21.15	20.90	19.89	16.62	13.28	9.73	7.67	5.72	4.65		
8.0	6.3	5.0		18.42	18.20	17.62	14.90	12.28	9.21	7.36	5.67	4.62	
9.6	7.6	6.0			15.52	15.52	15.42	13.89	11.82	9.02	7.26	5.69	4.69
11.2	8.9	7.0				12.81	12.74	12.82	11.96	10.40	8.23	6.63	5.31
12.8	10.1	8.0					10.49	10.51	10.49	9.91	8.72	6.95	5.71
10 Kft 26 AWG loop length with 6 Kft 26 AWG AdrenaLine placement gives 15.42 Mbps													
14 Kft 26 AWG loop length with 7 Kft 26 AWG AdrenaLine placement gives 8.23 Mbps													

2.2.2 ADSL Performance Expectations

See Table 2 and Table 5 through Table 7 for ADSL performance expectations.

Table 5. ADSL Downstream Lab Performance Example (Without AdrenaLine Installed)

Total Loop Distance												
Kft 22 AWG	11.2	12.8	14.4	16.0	17.6	19.2	20.8	22.4	25.1	26.8	30.4	32.2
Kft 24 AWG	8.9	10.1	11.4	12.7	13.9	15.2	16.5	17.7	19.7	21.1	23.3	24.7
Kft 26 AWG	7.0	8.0	9.0	10.0	11.0	12.0	13.0	14.0	15.0	16.0	17.0	18.0
Downstream Rates Mbps												
	8.17	8.17	8.17	7.62	5.73	4.41	3.5	2.61	1.89	1.31	0.99	0.69
14 Kft 26 AWG loop length gives 2.61 Mbps												
18 Kft 26 AWG loop length gives 0.69 Mbps												

Table 6. ADSL Downstream Lab Performance Example (With AdrenaLine CTA Installed)

Total Loop Distance												
	Kft 22 AWG	11.2	12.8	14.4	16.0	17.6	19.2	20.8	22.4	24.0	25.6	
	Kft 24 AWG	8.9	10.1	11.4	12.7	13.9	15.2	16.5	17.7	19.0	20.3	
	Kft 26 AWG	7.0	8.0	9.0	10.0	11.0	12.0	13.0	14.0	15.0	16.0	
CO To AdrenaLine CTA Placement			Downstream Rates Mbps									
Kft 22 AWG	Kft 24 AWG	Kft 26 AWG										
4.8	3.8	3.0	8.17	8.17	8.17	8.17	6.71	4.74	4.15			
6.4	5.1	4.0		8.17	8.17	8.17	6.82	5.05	4.08	3.05		
8.0	6.3	5.0			8.17	8.17	8.17	6.30	5.23	4.05	3.12	
9.6	7.6	6.0				8.17	8.17	8.17	6.58	4.95	4.12	3.25
11.2	8.9	7.0					8.17	8.17	7.86	5.36	4.40	3.43
12.8	10.1	8.0						8.17	8.06	7.13	4.91	4.08
14 Kft 26 AWG loop length with 7 Kft 26 AWG AdrenaLine placement gives 5.36 Mbps												

Table 7. ADSL Downstream Lab Performance Example (With AdrenaLine CRE Installed)

Total Loop Distance												
	Kft 22 AWG	20.8	22.4	24.0	25.6	27.2	28.8	31.8	35.8			
	Kft 24 AWG	16.5	17.7	19.0	20.3	21.5	22.8	25.0	27.4			
	Kft 26 AWG	13.0	14.0	15.0	16.0	17.0	18.0	19.0	20.0			
CO To AdrenaLine CRE Placement			Downstream Rates Mbps									
Kft 22 AWG	Kft 24 AWG	Kft 26 AWG										
9.6	7.6	6.0	8.17	7.62	6.09	4.99	3.60					
11.2	8.9	7.0	8.17	7.06	5.78	4.22	3.43	2.25				
12.8	10.1	8.0		6.37	5.09	4.15	3.05	2.35	1.59			
14.4	11.4	9.0			4.85	3.95	3.01	2.15	1.63	0.94		
14 Kft 26 AWG loop length with 7 Kft 26 AWG AdrenaLine placement gives 7.06 Mbps												
18 Kft 26 AWG loop length with 9 Kft 26 AWG AdrenaLine placement gives 2.15 Mbps												

Table 8. Single-Line Unit Application Limits with AdrenaLine

Model		26 AWG Cable* Minimum - Maximum	24 AWG Cable* Minimum - Maximum	22 AWG Cable* Minimum - Maximum	C-Message Noise, dBrnC, Nominal	Insertion Loss, dB, Nominal	CO Current, mA, Minimum
CTA-01L - Line Power, Shorter Loops	Loop Length	6 - 12.6 Kft	7.6 - 18 Kft	9.6 - 18 Kft	6	0.4	35
		500 - 1050 Ω	395 - 934 Ω	310 - 583 Ω			
	Placement	3 - 6 Kft	3.8 - 9.6 Kft	4.8 - 15.4 Kft			
250 - 500 Ω		197 - 500 Ω	156 - 500 Ω				
CRE-01L-S - Line Power, Longer Loops	Loop Length	11 - 15.6 Kft	13.9 - 25 Kft	17.6 - 36 Kft	6	0.4	35
		917 - 1300 Ω	723 - 1300 Ω	570 - 1166 Ω			
	Placement	5 - 8 Kft	6.7 - 12.8 Kft	8.6 - 20.2 Kft			
416 - 667 Ω		348 - 664 Ω	280 - 654 Ω				
CTA-01E - Express Power, Shorter Loops	Loop Length	6 - 16 Kft	7.6 - 22 Kft	9.6 - 29 Kft	1	1.2	10
		500 - 1333 Ω	395 - 1142 Ω	310 - 940 Ω			
	Placement	3 - 8 Kft	3.8 - 11 Kft	4.8 - 14 Kft			
250 - 666 Ω		195 - 571 Ω	155 - 454 Ω				
CRE-01E - Express Power, Longer Loops	Loop Length	16 - 21.3 Kft	22 - 28 Kft	29 - 36 Kft	1	1.2	10
		1333 - 1775 Ω	1142 - 1455 Ω	940 - 1166 Ω			
	Placement**	6.6 - 10.7 Kft	8.8 - 14 Kft	12 - 18 Kft			
550 - 890 Ω		455 - 725 Ω	390 - 585 Ω				

* Assuming buried cable at 20° C. ** Minimum CRE-01E to CPE ohm value is 500 ohms for 26 AWG, 450 ohms for 24 AWG, and 400 ohms for 22 AWG.
 Note: The nominal operating voltage is -48 VDC. The minimum AdrenaLine input voltage is -22 VDC (off-hook); maximum is -56 VDC.
 Note: Power consumption is approximately 250 mW.

3. OSP ENGINEERING

3.1 Verifying Loop Requirements

3.1.1 Loop Resistance

AdrenaLine should be placed at the ideal loop resistance point, which is to be measured or calculated in ohms for each individual application. It must be placed between the absolute maximum and minimum to function properly. Table 8 depicts minimum and maximum resistance levels and loop distances, in Kilofeet and ohms, for each AdrenaLine model.

- NOTE -

Charles Industries strongly recommends the actual resistance between the DSLAM and the AdrenaLine placement point be verified by measurement at the time of splicing.

3.1.2 AdrenaLine Powering Options

The decision to use **Line Power** or **Express Power** will be determined by the number of spare pairs available to transmit power for express power and the availability of an installed power source. Line power has distance limitations affecting required line current to the CPE (20 mA min.). Each AdrenaLine consumes 250 mW of power.

3.1.2.1 Line Power

Line-Powered units will require the normal POTs line power of -48 VDC, 35 mA. This assumes one cable pair carries both power and

signal. Table 8 provides limits for AdrenaLine by part numbers for line-powered units.

- NOTE -

If the DSLAM is located in an RT or DLC cabinet, there may not be sufficient voltage to the line-powered AdrenaLine to ensure it will remain functional when the CPE goes off-hook. Equipment in an RT is typically output current limited to preserve battery voltage. If this is the case, express power will be required for AdrenaLine deployment.

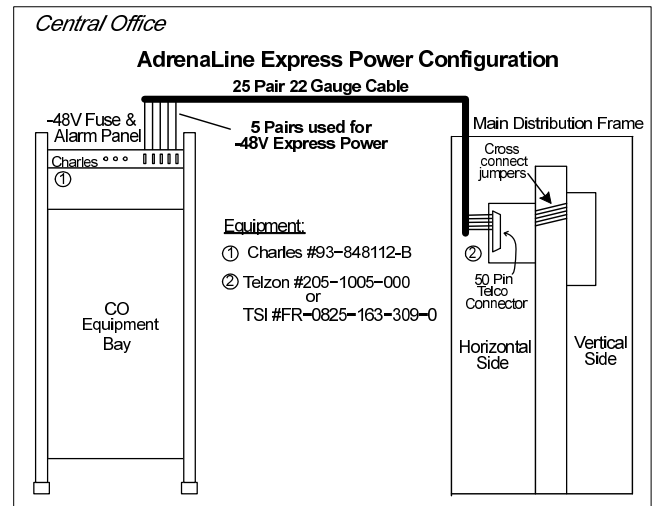

Figure 3. AdrenaLine Express Power Configuration

3.1.2.2 Express Power

Express-Powered units will require a separate power source of -48 VDC from either the CO or the RT. Figure 3 depicts an installed power source from the CO equipment bay to the main distribution frame. Table 8 provides limits for AdrenaLine by part numbers for express power.

Depending on the power source, distance, cable conditions, etc., up to five Express Power AdrenaLine units can be powered from a single power pair. When sizing a power pair, keep in mind the minimum operational requirements for each individual AdrenaLine unit. The minimum input voltage for each unit is -22 VDC. The minimum current requirement is 10mA for each unit. Reference the application note, *Powering Multiple Express Power AdrenaLine Units* for additional information.

- NOTE -

See the Troubleshooting section if problems occur after AdrenaLine is placed in a line that was properly conditioned as stated below.

3.1.3 Line Qualification or Conditioning for DSL & POTS*

The following network conditions, and the values stated, are critical to ensuring the wire pair into which AdrenaLine will be spliced is “conditioned” for carrying DSL signals and POTS. If the wire pair doesn’t comply with these values prior to installing AdrenaLine, Charles Industries strongly recommends the wire pair be modified to achieve or exceed these levels. All these parameters can be measured at the CPE NID using a Dynatel 950 (or equivalent) test set.

- NOTE -

If installing ADSL service in conjunction with AdrenaLine for the first time, check for any serious faults on the cable pair such as shorts, grounds, splits, opens, and actual loop length.

Equipment needed (verify all equipment is calibrated):

- Dynatel 950ADSL2+ (or equivalent) piece of equipment
- Standard telecom telephone test set
- Standard DMM (or equivalent) piece of equipment
- Standard TDR (or equivalent) piece of equipment

Check the following items to verify the line quality:

1. **Check and verify the fatness of the line (maximum obtainable downstream and upstream data rates):** It is essential to verify the actual achievable data rate that the pair

will support. (*See the note at the bottom of the page.) This is best accomplished by connecting a Dynatel 950ADSL2+ (or equivalent) test set (a modem can also be used) to the loop at the furthest CPE location served by AdrenaLine, and opening the DSLAM maximum downstream data rate setting to its highest setting (typically 32 Mb/s) and the DSLAM minimum downstream data rate to its lowest setting (typically 32 Kb/s). Also, set the DSLAM upstream data rates to their maximum and minimum settings (typically 1024 Kb/s and 32 Kb/s, see Table 9 and Table 10 for sample test profiles). After the DSLAM and test set or modem are in synchronization, obtain the Actual and Achievable downstream and upstream data rates from the DSLAM interface screen.

2. **Resistance (tip-ring, tip-ground, and ring-ground):** > 5 meg-ohms
3. **Input Capacitance:** = 0.083 μ F/mile
4. **DC Voltage:** Tip-ring polarity (ring must be negative with respect to tip)
5. **Replace standard load coils with Smart Coils if required to maintain POTS voice quality.**
6. **Remove any bridge taps:** If bridge taps are found but cannot be removed, it is recommended that no bridge tap be within 1000 feet of either modem. As the AdrenaLine, to some extent, replicates a modem, the bridge tap should not be within 1000 feet of it in either (up/downstream) direction.
7. **Offending transmission sources:** Follow local ADSL practices and guidelines for multiple services in the same cable/binder group.
8. **Insertion Loss:** \leq 8 dB prior to insertion of AdrenaLine (line powered AdrenaLine will add 0.4 dB nominal, express powered AdrenaLine will add 1.2 dB nominal)
9. **C-Message Noise:** \leq 20 dBmC prior to insertion of AdrenaLine (line powered AdrenaLine will add 6 dBmC nominal, express powered AdrenaLine will add 1 dBmC nominal)
10. **CO Voltage Requirement:** -48 VDC nominal

*The following standard documents are recommended for review.

1. *RUS Standard for Acceptance Tests and Measurements of Telecommunication Plant. This RUS Standard can be accessed via Internet at: <http://www.usda.gov/rus/telecom/publications/publications.htm>*
2. *American National Standards Institute (ANSI) T1.506-1997. This standard provides performance specifications for the two-way digital or digital equivalent transmission path between the exchange carrier’s end office and an interexchange carrier’s point of termination. This set of specifications will enable the provision of quality end-to-end performance for switched voice and voiceband data telephone services. This standard defines analog performance-related transmission parameters and specifies limits. This ANSI Standard can be purchased from two ANSI resellers:

 - Global Engineering Documents, 15 Inverness Way, East Englewood, CO 80112. www.global.ihs.com*
 - Techstreet, 777 East Eisenhower Parkway, Ann Arbor, MI 48108. www.techstreet.com**

- 11. **CO Current Requirement:** 10 mA minimum for express power, 35 mA for line power
- 12. **Total Loop Current at the NID (with AdrenaLine in place):** ≥ 20 mA
- 13. **AC Voltage, Tip-Ground:** < 5 VAC (should match ring-ground AC voltage)

Min SNR Margin	1.0 dB	1.0 dB
Bit Swapping	enabled	enabled

- 14. **AC Voltage, Ring-Ground:** < 5 VAC (should match tip-ground AC voltage)
- 15. **AC Voltage, Tip-Ring:** 0 VAC
- 16. **Longitudinal Balance:** ≥ 60 dB
- 17. **Power Influence:** ≤ 80 dBmC

Table 9. ADSL Line Test Profile Parameters

Name	ADSL Line Test Profile	
Transmission System	G.992_1	
Trellis Coding	enabled	
Reed Solomon	enabled	
S=1/2	enabled	
SRA	disabled	
SRA DownShift Interval	30 sec	
SRA UpShift Interval	30 sec	
Parameter	Downstream	Upstream
Max Bitrate	8192 kbps	1024 kbps
Min Bitrate	32 kbps	32 kbps
Max Delay	20 ms	20 ms
Impulse Noise Protection	1	1
Max SNR Margin	30.0 dB	30.0 dB
SNR Margin Upshift	9.0 dB	9.0 dB
Target SNR Margin	6.0 dB	6.0 dB
SNR Margin Downshift	3.0 dB	3.0 dB
Min SNR Margin	1.0 dB	1.0 dB
Bit Swapping	enabled	enabled

- NOTE -

*If turning up xDSL services with AdrenaLine on loop lengths greater than 18 Kft, and it was previously loaded, the line may require the addition of **Smart Coils**.*

When verifying the pair for use, it may be required to select a different pair in the binder group for deployment of the AdrenaLine due to the severity of the condition of the first pair chosen.

Table 10. ADSL2+ Line Test Profile Parameters

Name	ADSL2+ Line Test Profile	
Transmission System	G.992_5	
Trellis Coding	enabled	
Reed Solomon	enabled	
S=1/2	enabled	
SRA	enabled	
SRA DownShift Interval	30 sec	
SRA UpShift Interval	30 sec	
Parameter	Downstream	Upstream
Max Bitrate	32000 kbps	1024 kbps
Min Bitrate	32 kbps	32 kbps
Max Delay	0 ms	20 ms
Impulse Noise Protection	1	1
Max SNR Margin	30.0 dB	30.0 dB
SNR Margin Upshift	9.0 dB	9.0 dB
Target SNR Margin	6.0 dB	6.0 dB
SNR Margin Downshift	3.0 dB	3.0 dB

3.1.4 System Ground

Perform system grounding per local company practice.

3.2 Selecting Specific Product

The *AdrenaLine Placement Calculator* will recommend the appropriate unit based on the input provided.

3.3 Determining Product Placement

The best way to determine AdrenaLine placement is to use the *AdrenaLine Placement Calculator* at:

<http://www.charlesindustries.com/main/adrenalinetool.html>

For single-gauge loops, the ideal AdrenaLine placement is halfway between the DSLAM and the CPE (see Table 8 for more information). For multiple-gauge loops, you must use the AdrenaLine Placement Calculator mentioned above to find the ideal placement point. Install AdrenaLine as close as possible to the ideal placement location within the total CO/DSLAM-to-CPE loop, per local or company practice.

4. ADRENALINE INSTALLATION

Each AdrenaLine comes fully-assembled, prewired, encapsulated, and ready to install. Installation consists of inspecting the equipment, following all safety precautions (shown before Paragraph 4.2), determining the mounting location and type (see Paragraph 4.1), gathering the necessary tools and equipment, preparing the installation site, mounting the equipment, making all line wiring or splicing connections from the AdrenaLine to the feed cable, and any applicable site cleanup (see Paragraph 4.2).

- INSPECTION NOTE -

Visually inspect the unit for damage prior to installation. If the equipment was damaged in transit, immediately report the extent of the damage to the transportation company or according to local company practices and procedures.

- EQUIPMENT IDENTIFICATION NOTE -

Charles Industries' equipment is identified by a model and serial number imprinted on a label on the equipment. Please include both the model number and serial numbers when making equipment inquiries.

4.1 Determining Mounting Type

Prior to installing the AdrenaLine, the specific mounting type should be determined. AdrenaLine can be mounted in underground applications (manholes), in buried applications (handholes or pedestals), or in aerial applications (on poles).

4.1.1 Underground OSP Placement

The AdrenaLine xDSL Line Conditioner can be placed either inside or outside the manhole with a cable stub entry through the manhole wall.

4.1.1.1 Inside Manhole

Two methods of placement inside a manhole are recommended, and space availability will dictate which method will be used. One method is rack-mounting inside the manhole, and the other is wall mounting.

4.1.1.2 Outside Manhole

AdrenaLine can be placed outside the manhole with the cable stub entry through the manhole wall.

4.1.2 Buried OSP Placement

Buried applications place the AdrenaLine below the ground surface in three different configurations: direct buried near a direct buried splice case, in a handhole with a splice case, and direct buried near an above-ground pedestal.

4.1.2.1 Direct Buried

In direct-buried applications, the AdrenaLine is placed below grade (depth determined per company practice, but typically 24"-30") and spliced into a direct-buried splice case.

4.1.2.2 Handhole

In handhole applications, AdrenaLine is placed in a handhole, along with a splice case, for easy splicing.

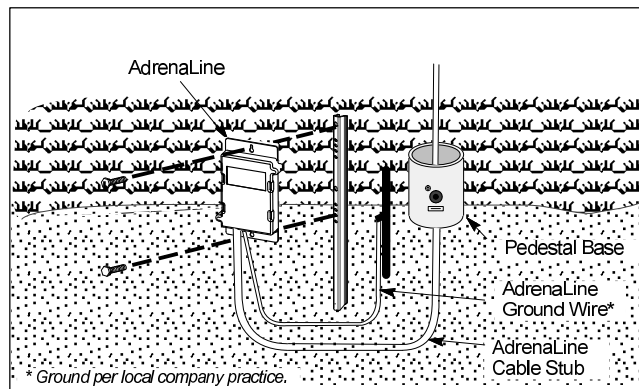

Figure 4. Above Grade Example with Buried Cable and Above-Grade Pedestal

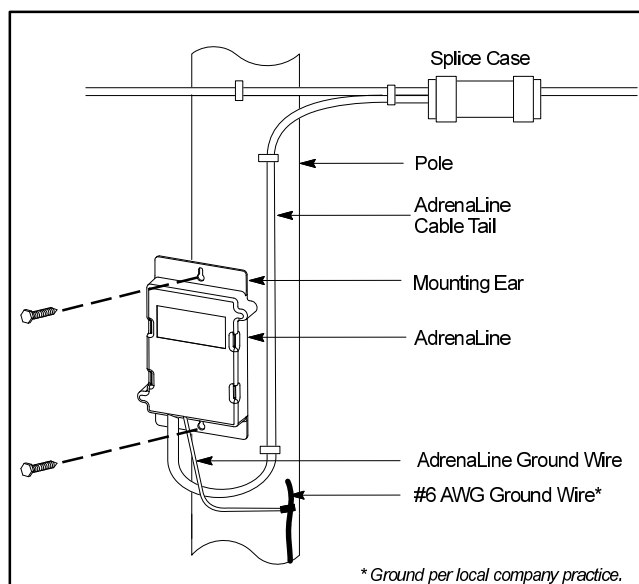

Figure 5. Aerial Installation Example on a Pole

4.1.2.3 Pedestal Housing

In pedestal housing applications, the AdrenaLine is buried adjacent to a pedestal, with the AdrenaLine cable-tail entering the pedestal through the bottom of the pedestal base, as shown in Figure 4.

4.1.3 Aerial OSP Placement (Pole)

In aerial applications, the AdrenaLine is mounted to a pole, as shown in Figure 5.

- CAUTION -

Perform all bonding and grounding prior to any electrical and communications connections.

- GROUNDING WARNING -

Always follow local codes and company practices for performing proper cable and site bonding and grounding.

- WARNING -

Be careful not to damage any buried cables or service wires while digging to prepare a hole/trench, to expose cables or while driving stakes.

4.2 Installing the Selected AdrenaLine Unit

Once the specific AdrenaLine unit to install has been selected, received, and inspected, and the type of mounting has been determined (Paragraph 4.1), follow the steps enumerated below to install the AdrenaLine.

- Obtain tools, materials, and equipment.** Assemble all the equipment and tools necessary to install and mount the AdrenaLine, according to the mounting type. The following are either required or helpful:

Required:

- Charles AdrenaLine model of choice
- Cable grounding materials and equipment
- Mounting screws or bolts or other fastening hardware (2)
- Bolt or screw driving tools (*screwdriver/wrenches/socket set*)
- Line or wire splicing and connection equipment

Optional:

- Trenching equipment, and/or digging or soil moving tools
- Cable preparation & sheath opening tools and equipment
- Conduit and conduit caps
- Hammer, mallet, or sledgehammer (*to pound metallic stakes*)
- Site cleanup tools and containers
- Insulated* work gloves (*for use when pounding metallic stakes*)
- Mounting stake Spray paint
- Level Tape measure
- Safety glasses Work gloves

- Locate the exact mounting location.** Find the predetermined, proposed, installation area per company practice and then select the best AdrenaLine mounting location within that area.
- Establish an earth ground.** *Always follow local codes and company practice when preparing earth ground and when grounding cables/equipment.* Verify an earth ground is or will be accessible and available at or near the mounting location. If an earth ground must be prepared, prepare one per local codes and per local company practice.
- Prepare the site.** Prepare the site to accept the AdrenaLine unit and also prepare the upstream or nearby splice case which will be used to connect the AdrenaLine cable tail

wires. Prepare any necessary cable trench per local company trenching requirements.

- Route the AdrenaLine cable tail.** Route the cable tail of the AdrenaLine unit toward the splice case, pedestal, or housing. Follow company practice for cable support, slack, and storage concerns or requirements.

- CAUTION -
Do not excessively bend the cable - observe proper cable bend radius requirements.

- Mark mounting holes.** For wall or pole mounting, place the AdrenaLine up against the wall or pole in the proposed final mounting position and mark the exact mounting hole locations on the wall or pole. For rack or stake mounting, determine and mark which rack or stake mounting holes will be used to mount the AdrenaLine.

- Mount the AdrenaLine unit.** Gather all materials, follow all safety precautions and local codes, prepare the installation site, and mount the unit.

- CAUTION -
Do not overtighten the mounting bolts, to prevent accidental cracking of the housing.

- Determine, measure, and mark cable tail sheath opening point.** Sheath preparation and the length of exposed cable wire for splicing will depend on the type of splice housing used when splicing the AdrenaLine cable tail. Adequate AdrenaLine cable stub wire should be made available according to the existing splice arrangement. Mark the cable sheath opening point on the AdrenaLine cable tail stub after determining or establishing an adequate length of cable wire to match the existing splice.

- Score, cut, and open the cable sheath.** *Always follow safety precautions when working with cables and cable opening and cutting tools.* Perform the cable sheath opening procedure, per local practices.

- Bond the cable tail.** Perform cable bonding with a cable bond clamp at the cable tail sheath opening, then bond the cable at the clamp to an approved ground with a bond strap or wire, all per local company practice.

- Ground AdrenaLine's green ground wire.** Connect the external, green, ground wire on the AdrenaLine unit to an approved earth ground, per local company practice.

- Perform splicing.** Open the splice case and perform splicing per local company practice. Refer to Table 11 and Table 12 as needed.

CO side	Tip/Ring	White-Blue/Blue
CPE side	Tip/Ring	White-Orange/Orange
Not Used	Not Used	White-Green/Green

Table 11. Cable-Stub Wire Colors - Line Power

CO side	Tip/Ring	White-Blue/Blue
CPE side	Tip/Ring	White-Orange/Orange
Grd/Power (-48 VDC)	Tip/Ring	White-Green/Green

Table 12. Cable-Stub Wire Colors - Express Power

4.3 Testing the Installation

- NOTE -

Important: AdrenaLine line-powered units are polarity sensitive and should be spliced "Tip to White-Blue" and "Ring to Blue" conductors.

Test or verify the connections for proper operation and make any needed corrections, changes or adjustments, per local company practice. Verify -48 VDC is on the blue wire of the AdrenaLine unit.

5. OSP MAINTENANCE AND TROUBLESHOOTING

After installing AdrenaLine into the network using the guidelines in Part 3, use Table 15 and Figure 6 to help diagnose troubles that may occur after AdrenaLine is installed into the network.

6. TECHNICAL ASSISTANCE

If technical assistance is required, contact Charles Industries' Technical Services Department by calling or using one of the following options:

- 847-806-8500 (Tech. Service local)
- 800-607-8500 (Tech. Service toll-free)
- 847-806-8556 (Tech. Service FAX)
- techserv@charlesindustries.com (email)

- EQUIPMENT IDENTIFICATION NOTE -

Charles Industries' equipment is identified by a model and serial number imprinted on a label on the front of the equipment. Please include both the model number and serial numbers when making equipment inquiries.

7. WARRANTY

Charles Industries, Ltd. offers a 1-year limited warranty for materials and workmanship on AdrenaLine products. Contact your local Sales Representative or the Charles Customer Service Department at the address or telephone numbers below for warranty details. The warranty provisions are subject to change without

notice. The terms and conditions applicable to any specific sale of product shall be defined in the resulting sales contract.

Charles Industries, Ltd.
 5600 Apollo Drive
 Rolling Meadows, Illinois 60008-4049
 847-806-6300 (Customer Service)
 847-806-6653 (Customer Service FAX)
 mktserv@charlesindustries.com (email)
 www.charlesindustries.com (website)

8. RETURNS AND REPLACEMENT

For inquiries regarding returns and replacements of AdrenaLine units, please consult Charles Industries, Ltd. Technical Services department. Reference the Technical Assistance section of this document for contact information.

9. SPECIFICATIONS

9.1 Electrical and Physical Specifications

See Table 1 for electrical and signalling specifications, and Table 13 for physical specifications.

Table 13. Physical Specifications, Single-Line Units

Feature	CTA-01E, CTA-01L & CRE-01E	CRE-01L-S Only
Width, including brackets	7 in. (17.8 cm)	5.2 in. (13.2 cm)
Height, including brackets	10.6 in. (26.9 cm)	10.8 in. (27.4 cm)
Height, without brackets	8.125 in. (20.6 cm)	7.7 in. (19.6 cm)
Mounting hole centers	9.25 in. (23.5 cm)	9.75 in. (24.8 cm)
Length, cable stub, BSW 24 ga.	30 feet (9.14 m)	30 ft. (9.14 m)
Length, 14 ga. ground cable	10 feet (3.05 m)	10 ft. (3.05 m)
Depth	2 in. (5.1 cm)	1.5 in. (3.8 cm)
Weight (w/o cable, approx.)	3 lbs. (1.3 Kg)	2.2 lb. (1 Kg)
Operating Temperature	-40° to 150°F (-40° to 65°C)	

NOTE: All dimensions and weights are approximate.

9.2 Ordering Information

To order units, call the telephone number shown in Part 7 and please specify a specific model number shown in Table 14.

Model #	# of Lines	Power
CTA-01L	1	Line Power (same pair)
CRE-01L-S	1	
CRE-01E	1	Express Power (separate pair)
CTA-01E	1	

The availability of features and technical specifications herein subject to change without notice.

Table 14. AdrenaLine™ Series Model Numbers

9.3 Trademark Information

AdrenaLine is a Charles Industries product founded upon Phylogy's TripleStream technology and is sold and manufactured by Charles under agreement with Phylogy. Patent pending.

- *Charles*® is a registered trademark of Charles Industries, Ltd.
- *AdrenaLine*™ is a trademark of Charles Industries, Ltd.
- *Phylogy*® is a registered trademark of Phylogy.
- *TripleStream*® is a registered trademark of Phylogy.
- *Splice and Walk Away*® is a registered trademark of Phylogy.

9.4 Compliance Information

- CLASS compatible
- E911 compliant

9.5 Acronyms & Abbreviations

The following acronyms, abbreviations, and trademarks are found in this practice.

ADSL -	Asymmetric Digital Subscriber Line
AdrenaLine™	AdrenaLine is a trademark of Charles Industries.
ADSL2 -	Second generation ADSL, also known as ITU G.992.3/4, capable of extending ADSL data rates to 12 Mb/s downstream and 3.5 Mb/s upstream.
ADSL2+ -	Next generation of ADSL, also known as ITU G.992.5, capable of extending the data rates to 24 Mb/s downstream and 1 Mb/s upstream by doubling ADSL transmission speed from 1.1 MHz to 2.2 MHz.
AWG -	American Wire Gauge
C -	Celsius
CEV -	Controlled Environment Vault
CI -	Charles Industries
CKT -	Circuit
cm -	Centimeter
CO -	Central Office

CPE -	Customer Premises Equipment
CRE -	Charles, Reach Extended
CTA -	Charles, Tripleplay ADSL
CV -	Code Violations
dB -	decibel
DLC -	Digital Loop Carrier
DMM -	Digital Multi-Meter
DSL -	Digital Subscriber Line
DSLAM -	DSL Access Multiplexer
EN -	European Norm
F -	Fahrenheit
GR -	Generic Requirement
HDSL -	High-bit-rate Digital Subscriber Line
Hz -	Hertz
in. -	inch
ITU -	International Telecommunications Union
Kbps -	Kilobits per second
KHz -	KiloHertz
MHz -	MegaHertz
Mb/s -	Megabits per second
ms -	millisecond
mW -	milliWatt
NID -	Network Interface Device
OSP -	OutSide Plant
POTS -	Plain Old Telephone Service
PSD -	Power Spectral Density
RT -	Remote Terminal
SNR -	Signal to Noise Ratio
SR -	Special Report
TDR -	Time Domain Reflectometer
TripleStream®	TripleStream is a product and trademark of Phylogy®, Inc.
UL -	Underwriter's Laboratories
VAC -	Volts, Alternating Current
VDC -	Volts, Direct Current
VoIP -	Voice over Internet Protocol
W -	Watts

10. TROUBLESHOOTING

The following section may be referenced when troubleshooting the AdrenaLine unit.

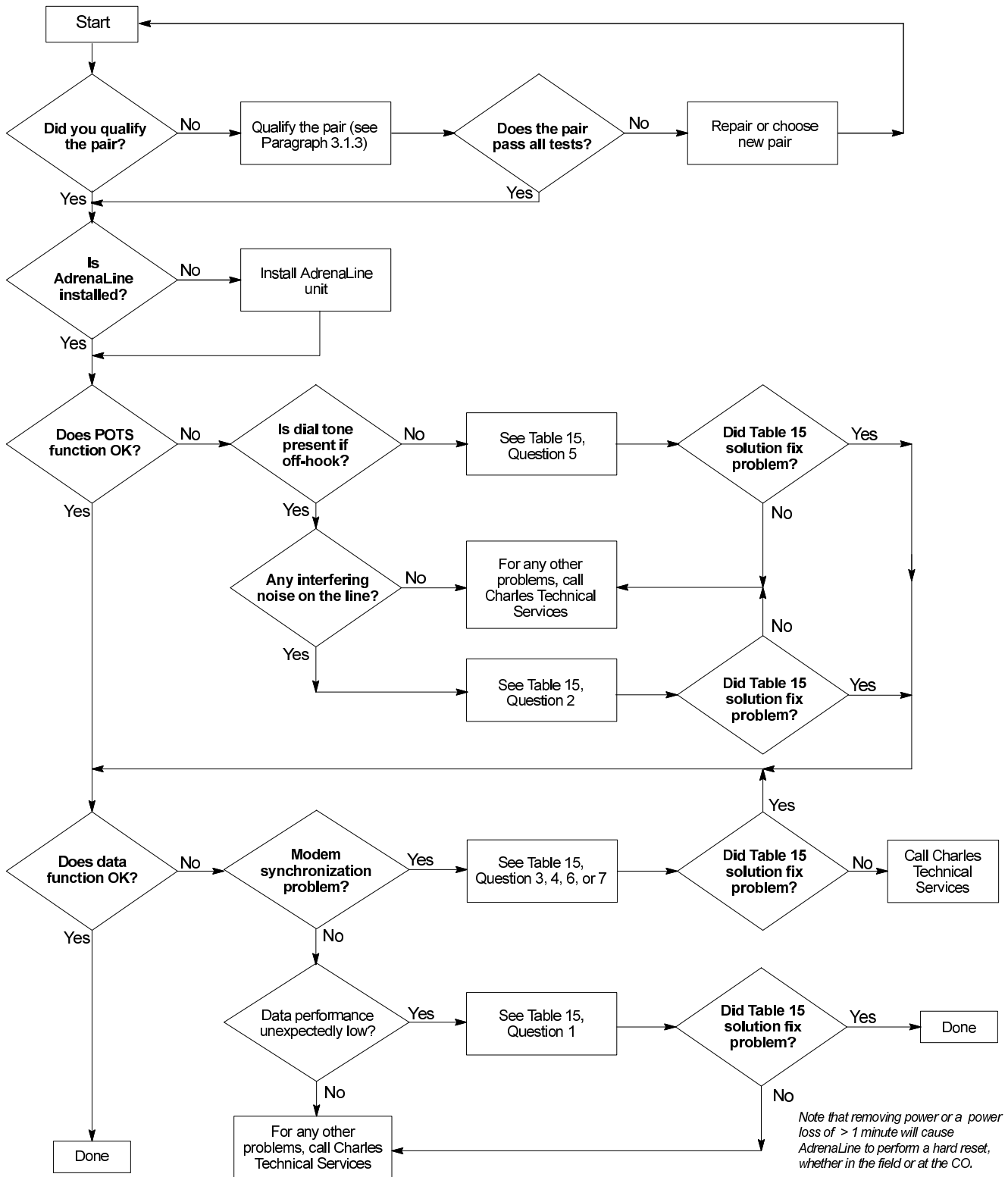

Figure 6. AdrenaLine Troubleshooting Flowchart

Table 15. Troubleshooting Questions and Answers	
Problem	Solution
<p>1. I am not getting the downstream data rates that I expected after installing AdrenaLine.</p>	<p>Assuming synchronization has occurred, if the expected downstream and upstream data rates are not achieved (see Table 3 through Table 7), follow these steps:</p> <p>A. Verify the AdrenaLine placement is per these guidelines. Correct the placement as needed.</p> <p>B. Refer to the <i>Line Qualification</i> section (see Paragraph 3.1.3). Check and verify the fatness of line. If the line meets the standards set forth in the <i>Line Qualification</i> requirements, proceed to Step C. If the line does not meet the standards set forth in the <i>Line Qualification</i> requirements, follow standard local practices, correct the problem areas, and re-test.</p> <p>C. If the problem persists, capture the DSLAM settings, and consult with Charles Industries' Technical Support for further guidance.</p> <p><i>Note: When re-verifying the pair for use, it may be required to select a different pair in the binder group for deployment of the AdrenaLine due to the severity of the condition of the first pair chosen.</i></p>
<p>2. I can hear a "hum" in the receiver of my phone that I didn't hear before I installed AdrenaLine.</p>	<p>Assuming synchronization has occurred, if audible noise occurs, follow these steps:</p> <p>A. At the NID, with the AdrenaLine in place, disconnect the house from the line and verify the audible noise. If audible noise is verified, proceed to Step B. If audible noise is not verified, the problem is in the house. Follow local practices to correct the problem.</p> <p>B. At the NID, verify the following measurements without the AdrenaLine on the line, as the line may have changed from the initial qualification of the line (e.g., moisture in cable, loose grounds, or high resistance connections). <u>Equipment Needed:</u> <input type="checkbox"/> Dynatel 950ADSL2+, or equivalent piece of equipment <input type="checkbox"/> Standard Telecom telephone test set</p> <ul style="list-style-type: none"> <input type="checkbox"/> AC voltage, tip-ground: Measure VAC RMS (should be < 5 VAC and match ring-ground measurement) <input type="checkbox"/> AC voltage, ring-ground: Measure VAC RMS (should be < 5 VAC and match tip-ground measurement) <input type="checkbox"/> AC voltage, tip-ring: 0 VAC RMS <input type="checkbox"/> Longitudinal balance: ≥ 60 dB <input type="checkbox"/> Power influence: ≤ 80 dBrc <input type="checkbox"/> Circuit noise (C-message): ≤ 20 dBrc <p>After making the above measurements, if the line is not within the recommended guidelines, follow standard company guidelines to bring the values within specification(s). If the line is found to be within specification(s) or if correction(s) were made to bring the line within specification(s), replace the AdrenaLine and take another set of measurements (also see the notes in the next step).</p> <p>C. If audible sound still persists, consult Charles Industries' Technical Support for further assistance.</p> <p><i>Notes:</i></p> <ul style="list-style-type: none"> <input type="checkbox"/> <i>If an audible sound is heard <u>prior</u> to the installation of the AdrenaLine, the audible sound will still be present after AdrenaLine.</i> <input type="checkbox"/> <i>If the total loop length was greater than 18 Kft and it was previously loaded, the line may require the addition of the Smart Coil to bring the line back into specification.</i> <input type="checkbox"/> <i>With the addition of the AdrenaLine on the line, the Circuit Noise will increase by 1dB nominal for the CTA-01E and 6 dB nominal for the CTA-01L.</i>

Table 15. Troubleshooting Questions and Answers

Problem	Solution
<p>3. My modem loses synchronization with the DSLAM when I lift the phone off-hook. Synchronization occurred for longer than 5 minutes after a <u>Line Powered</u> AdrenaLine unit was first installed.</p>	<p>There are two common causes for this condition: 1) Tip-Ring polarity is reversed, and 2) the DSLAM is in an RT or DLC cabinet and is likely not providing sufficient current to guarantee the AdrenaLine unit input voltage of -22 VDC when the CPE phone goes off-hook.</p> <p>A. Get the following equipment, which may be needed:</p> <ul style="list-style-type: none"> <input type="checkbox"/> A standard DMM, or equivalent piece of equipment. <p>B. Verify the polarity of the Tip and Ring leads (Ring must be negative with respect to Tip). If polarity is incorrect, make corrections as needed and re-verify. If polarity is correct, proceed to the next step.</p> <p>C. Verify the following measurements:</p> <ul style="list-style-type: none"> <input type="checkbox"/> CO voltage, -44 to -56 VDC. <input type="checkbox"/> CO current, 35 mA minimum (off-hook). <input type="checkbox"/> Loop current at CPE, 20 mA min. within the placement guidelines of AdrenaLine (off-hook). <input type="checkbox"/> AdrenaLine input voltage, -22 VDC minimum when off-hook. <p>If any of the measurements are out of specification, make corrections and re-verify.</p> <p>D. If the problem persists, consult Charles Industries' Technical Support for further assistance.</p>
<p>4. My modem loses synchronization with the DSLAM when I lift the phone off-hook. Synchronization occurred for longer than 5 minutes after an <u>Express Powered</u> AdrenaLine unit was first installed.</p>	<p>A. Verify the following measurements:</p> <ul style="list-style-type: none"> <input type="checkbox"/> CO voltage, -44 to -56 VDC (at CO or RT) <input type="checkbox"/> Current, 10 mA minimum <input type="checkbox"/> Input voltage at the AdrenaLine, -22 VDC minimum (Power Pair) <p>If any of the measurements are out of specification, make corrections and re-verify.</p> <p>B. If the problem persists, consult Charles Industries' Technical Support for further assistance.</p>
<p>5. I do not have POTS functionality, and I did before I installed AdrenaLine.</p>	<p>A. Get the following equipment, which may be needed:</p> <ul style="list-style-type: none"> <input type="checkbox"/> Standard Telecom telephone test set <p>B. At the NID, with AdrenaLine in place, disconnect the house from the line and verify dial tone. If dial tone is achieved, the problem is in the house. Follow local practices to correct the problem.</p> <p>C. Test for dial tone at the AdrenaLine unit on the white/blue pair. If no dial tone, the problem is in the CO or between the CO and AdrenaLine unit.</p> <p>D. Check for dial tone at the AdrenaLine unit on the white/orange pair. If dial tone is ok, then the problem is between the AdrenaLine unit and the NID. If no dial tone, replace AdrenaLine unit and re-test.</p>
<p>6. My modem loses synchronization with the DSLAM for short periods up to 2 minutes. The modem and DSLAM were synchronized for greater than 5 minutes after I installed AdrenaLine.</p>	<p>A. Get the following equipment, which may be needed:</p> <ul style="list-style-type: none"> <input type="checkbox"/> Dynatel 950ADSL2+, or equivalent piece of equipment <input type="checkbox"/> Standard Telecom telephone test set <p>B. Disconnect the house from the line at the NID.</p> <p>C. Verify the AdrenaLine placement is within the recommended guidelines by taking actual resistance measurements between the DSLAM and the AdrenaLine, and between the AdrenaLine and the CPE. If placement is incorrect, relocate AdrenaLine as necessary and re-verify. If placement is correct, proceed to the next step.</p> <p>D. Confirm the loss of synchronization at the NID (or, for CTA-01L and CTA-01E units, at the NID or AdrenaLine unit splice point) by monitoring the data rate and POTS performance, using a Dynatel 950ADSL2+, or equivalent piece of equipment. If loss of synchronization is confirmed, consult with Charles Industries Technical Support for further assistance. If no loss of synchronization is confirmed, proceed to the next step.</p> <p>E. Re-connect the house and re-verify loss of synchronization. If the problem persists, correct the problem in the house, using company standard practices.</p>

Table 15. Troubleshooting Questions and Answers

Problem	Solution
<p>7. I have waited for 5 minutes after installing AdrenaLine and the modem and DSLAM have never synchronized.</p>	<p>A. Get the following equipment, which may be needed :</p> <ul style="list-style-type: none"> <input type="checkbox"/> Dynatel 950ADSL2+, or equivalent piece of equipment <input type="checkbox"/> Standard Telecom telephone test set <input type="checkbox"/> A standard DMM or equivalent piece of equipment <p>B. Verify that the line has been qualified.</p> <p>If the line was not qualified, refer to Paragraph 3.1.3 to qualify the line.</p> <p>If the line was previously qualified, proceed to the next step as the line may have changed from the initial qualification.</p> <p>C. Verify the AdrenaLine placement is within the recommended guidelines by taking actual resistance measurements between both the DSLAM and the AdrenaLine, and between the AdrenaLine and the CPE.</p> <p>If placement is incorrect, relocate the AdrenaLine as necessary and re-verify.</p> <p>If placement is correct, proceed to the next step.</p> <p>D. Verify the following measurements at the CO or RT:</p> <ul style="list-style-type: none"> <input type="checkbox"/> Verify minimum output current, (Line power, 35 mA with the customer telephone off-hook, Express Power, 10 mA) <input type="checkbox"/> Verify output voltage (-44 to -56 VDC) <p>If any of the measurements taken are out of specification, make corrections and re-verify.</p> <p>If measurements are in line with the minimum specification, proceed to the next step.</p> <p>E. Perform a reset on the AdrenaLine by disconnecting battery at the CO for at least 1 minute.</p> <p>F. Verify the following measurements at the AdrenaLine:</p> <ul style="list-style-type: none"> <input type="checkbox"/> Verify polarity of the Tip and Ring leads (Ring must be negative with respect to Tip). If polarity is incorrect, make corrections as needed. <input type="checkbox"/> Verify minimum output current (Line power, 35 mA, Express Power, 10 mA) <input type="checkbox"/> Verify minimum output voltage (22 VDC, on-hook or off-hook) <p>If any of the measurements taken are out of specification, contact Charles Industries' Technical Support for further assistance.</p> <p>If measurements are in line with the minimum specification, proceed to the next step.</p> <p>G. Using a Dynatel 950ADSL2+ or equivalent piece of equipment, confirm AdrenaLine's operation by monitoring the data rate and POTS performance at a point just beyond the AdrenaLine. <i>Note, select a location for monitoring that is at least 0 ohms for CTA-01L and CTA-01E units, or for CRE-01E units, at least 500 ohms for 26 AWG, 450 ohms for 24 AWG, and 400 ohms for 22 AWG, from the AdrenaLine, towards the CPE.</i></p> <p>If AdrenaLine performance is not what is expected, consult with Charles Industries Technical Support for further assistance.</p> <p>If performance of the AdrenaLine is within expectations, proceed to next step.</p> <p>H. Verify the following measurements, at the NID, with the line disconnected from the house:</p> <ul style="list-style-type: none"> <input type="checkbox"/> Verify minimum current at the NID with the telecom telephone test set off-hook (Line power unit, 20 mA; Express power unit, AdrenaLine Independent). <p>If measurements are within the minimum specification, proceed to the next step.</p> <p>I. Confirm operation of the AdrenaLine at the NID by monitoring the data rate and POTS performance using a Dynatel 950ADSL2+ or equivalent piece of equipment (with the CPE disconnected at the NID).</p> <p>If the problem persists, consult Charles Industries' Technical Support for further assistance.</p> <p>If the operation of the AdrenaLine and POTS performance is confirmed, proceed to next step.</p> <p>J. Re-connect the house and re-verify performance.</p> <p>If problem persists, correct the problem in the house, using company standard practices.</p>