

3660-03 2W ARD/MRD Channel Unit 600 Ohms

CONTENTS	PAGE
Part 1. GENERAL	2
Part 2. APPLICATION GUIDELINES	2
Part 3. CIRCUIT DESCRIPTION	3
Part 4. INSPECTION	6
Part 5. MOUNTING	6
Part 6. INSTALLER CONNECTIONS	6
Part 7. OPTIONS	7
Part 8. TESTING	8
Part 9. TECHNICAL ASSISTANCE	8
Part 10. WARRANTY & CUSTOMER SERVICE	8
Part 11. SPECIFICATIONS	10

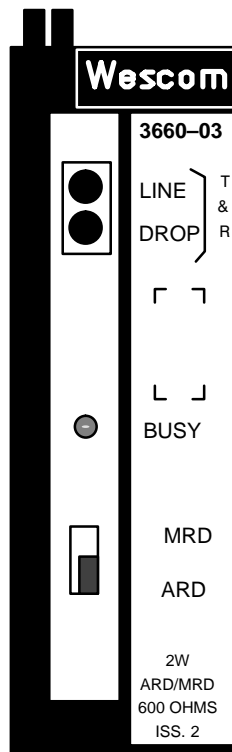

Figure 1. 3660-03 2W ARD and MRD Channel Unit (Issue 2)

1. GENERAL

1.1 Document Purpose

This document provides information on the Charles Industries 3660–03 2-Wire ARD/MRD Channel Unit. The 3660–03 is shown in Figure 1.

1.2 Document Status

This document is reprinted to include a general editorial update.

1.3 Equipment Function

The channel unit is used in the Charles Industries 360/363 D4 Digital Carrier Terminal to provide an interface to ringdown type circuits.

1.4 Equipment Mounting

The 3660–03 mounts in any channel unit slot of a 360/363 D4 terminal. The 3660–03 is equipped with an insert/eject lever in the form of a hinged front panel which ensures a positive connection of the channel unit's card-edge connector to the backplane connector when the unit is installed. The insert/eject lever also facilitates removal of the unit.

1.5 Equipment Features

The 3660–03 channel unit includes the following features:

- Two Automatic Ringdown modes: Standard PLAR or FXS Ringdown
- Two Manual Ringdown modes: No Code or Repeat Input
- 600 ohm +2.15 uF 2W impedance
- Input TLP range: –16 to +0.5 dBm
- Output TLP range: –16.5 to 0.0 dBm
- Built-in hybrid-balancing network
- Integral precision ringback tone generator
- Front-panel BUSY LED indicator
- Front-panel bantam breaking jacks for accessing the 2-wire facility
- Short-loop control (less than 300 ohms)

2. APPLICATION GUIDELINES

The 3660–03 can be optioned for either Automatic (ARD) or Manual (MRD) Ringdown. In the ARD configuration, the 3660–03 provides for two types of automatic ringdown modes: Standard PLAR or FXS Ringdown. In the MRD configuration, the 3660–03 provides for two types of manual ringdown modes: No Code or Repeat Input. Refer to the following paragraphs and Figure 2, Figure 3, and Figure 4 for descriptions of each mode of operation.

2.1 Automatic Ringdown (ARD)

In ARD configuration, Standard PLAR or FXS Ringdown mode is used. Figure 2 shows a typical Standard PLAR application. The 3660–03 at the East End and the 3660–03 (or equivalent) at the West End are both set for PLAR operation and the same signaling (D3 or D4). Figure 3 shows a typical FXS Ringdown application. The 3660–03 at the East End is set for FXS Ringdown and the FXS unit at the West End is set for loop start operation. Basic operation is the same in both modes. When a telephone at either end goes off-hook, interrupted ringing is applied to the telephone at the other end. When the telephone is answered, ringing is removed automatically and voice communication can begin. Both ends must return to onhook before a new call can begin.

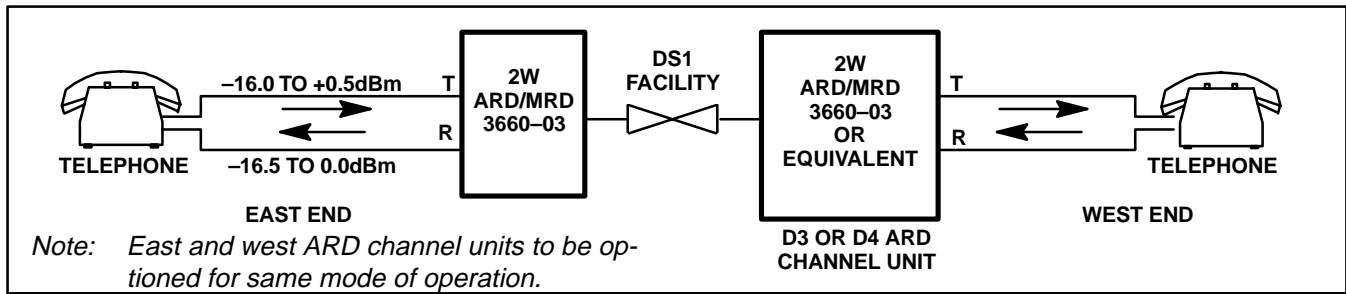

Figure 2. Typical Standard PLAR Application

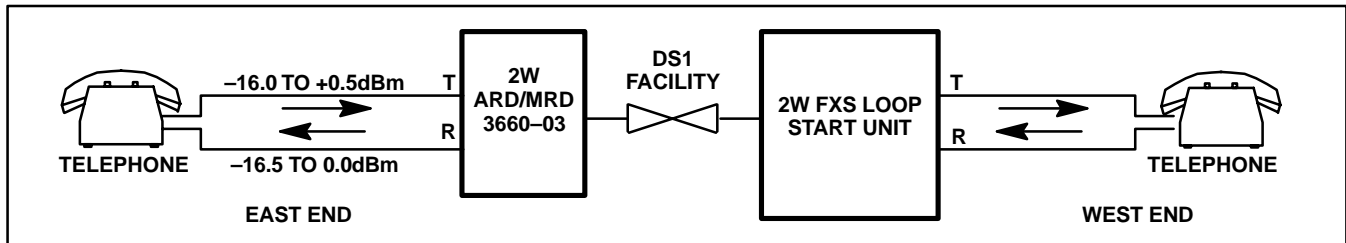

Figure 3. Typical FXS Ringdown Application

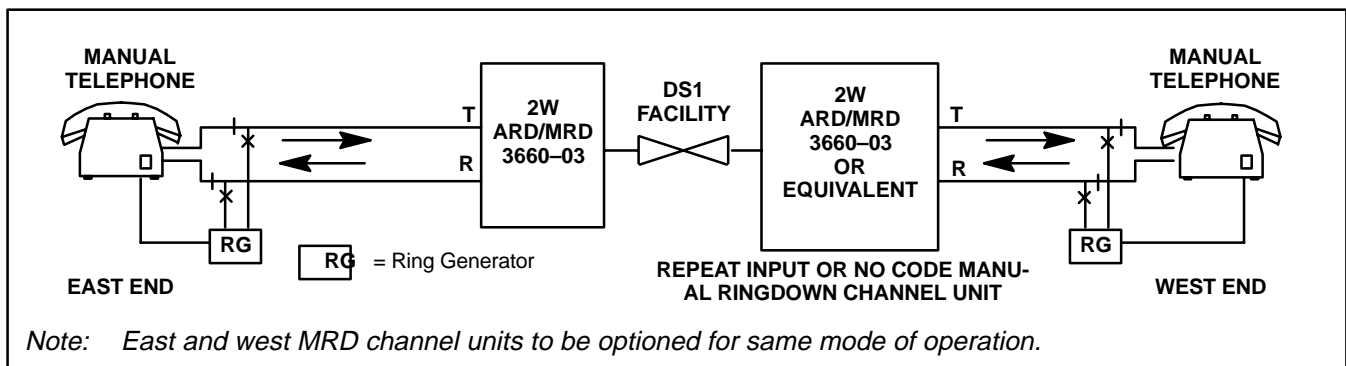

Figure 4. Typical Repeat Input Manual or No Code Manual Ringdown Application

2.2 Manual Ringdown

In the MRD configuration, the No Code or Repeat Input Manual Ringdown mode is used. Referring to Figure 4, when the ringing voltage is applied to the 2W facility at the East End, the 3660-03 passes this ringing signal over the DS1 Facility to the West End Channel Unit. If the West End Channel Unit is set in the No Code Manual Ringdown mode, a single two-second burst of ringing voltage is applied toward the West End Telephone when ringing voltage is removed from the 2W facility at the East End. If the West End Channel Unit is set for Repeat Input Manual Ringdown, ringing voltage is repeated toward the West End Telephone as it was applied by the East End.

3. CIRCUIT DESCRIPTION

Refer to Figure 5, the 3660-03 (Issue 2) block diagram, while reading the following circuit description.

3.1 Transmit VF Path

VF (Voice Frequency) signals applied to the input T&R (pins 50 and 48) are routed through the DROP and LINE breaking-jacks to the 2W/4W HYBRID circuit. The 2W/4W HYBRID extracts the transmit signal from the combined signal at the 2-wire input.

The output of the 2W/4W HYBRID is adjusted via the XMT PRESCRIPTION ATTEN circuit which provides 0 to 16.5dB of attenuation in 0.1dB increments for adjusting the input level to achieve a +5.2dBm level at the input to the ENCODER. The input T&R leads will accept a TLP range from -16.0 to +0.5dBm.

The transmit signal from the XMT PRESCRIPTION ATTEN is passed to the XMT CUT circuit. The transmit path is cut whenever ringing is applied to or received at the 2W input. The VF signal is sent to the summing amp. Ringback tone is inserted here into the transmit path toward the originating station when ringing is applied to T&R. The VF signal is then applied to the XMT FILTER for suppression of frequencies that are outside the bandwidth of the standard voice frequency and prevents them from entering the ENCODER.

3.2 Receive VF Path

The PCM digital signal transmitted from the far-end is received by the 360/363 D4 terminal common equipment and, in turn, is routed to the 3660–03 via the RDATA lead. The DECODER and RCV FILTER then, in turn, perform a Digital-to- Analog (D/A) conversion of the signal.

The receive signal from the RCV FILTER is passed to the summing amp. When the 3660–03 is set for FXS Ring-down and detects loop closure at T&R, the receive path is cut at the RCV FILTER and ringback tone inserted at the summing amp toward the local station.

The receive signal from the summing amp is then applied to the RCV PRESCRIPTION ATTEN circuit which provides 0 to 16.5dB of attenuation in 0.1dB increments for adjusting the level to the desired output level at T&R. The 2W output level can be adjusted from 0.0 to –16.5dBm.

3.3 Transmit Signaling

The 3660–03 will detect Loop-Closure (LC) in the Automatic Ringdown mode and detect ringing in the Manual Ringdown modes.

Note: In the Automatic Ringdown mode, the BATTERY FEED AND CURRENT DETECTOR is connected to the 2W facility through the 2W/4W HYBRID circuit. The BATTERY FEED AND CURRENT DETECTOR circuit provides talk-battery to the telephone connected to the other end of T&R and detects loop closure. Loop closure information is processed by the CONTROL LOGIC. This information is then sent to the ENCODER to be multiplexed onto the T1 line as the A&B signaling bits.

Note: In the Manual Ringdown modes, the RINGING DETECTOR is connected to the 2W facility through the 2W/4W HYBRID circuit. The RINGING DETECTOR circuit detects ringing applied to T&R by the manual ringdown station connected to the other end of T&R (talk-battery is not supplied by the 3660–03 in the Manual Ringdown modes). The ringing information is then passed on to the CONTROL LOGIC and the ENCODER to be multiplexed on to the T1 line, as stated in the Automatic Ringdown mode.

3.4 Receive Signaling

The 3660–03 provides interrupted ringing (2 seconds on and 4 seconds off) for the Automatic Ringdown modes; continuous ringing for the Repeat Input Manual Ringdown mode; and two-second burst for the No Code Manual Ringdown mode.

3.4.1. Standard PLAR or FXS Ringdown Mode

The DECODER extracts the A and B signaling bits from the received PCM word during the 6th and 12th frames, respectively. The B bit is ignored, and the A bit is sent through the CONTROL LOGIC. When an off-hook signal is received from the far-end, the CONTROL LOGIC enables the 2X4 SECOND TIMER to operate the R RELAY. This applies ringing voltage (2 seconds on and 4 seconds off) to the local station. If the local station goes off-hook during the ringing period, the RING TRIP DETECTOR detects loop closure and disables the R RELAY. The BATTERY FEED AND CURRENT DETECTOR is then connected back to T&R through the 2W/4W HYBRID circuit. If the local station goes off-hook during the silent period, the BATTERY FEED AND CURRENT DETECTOR detects loop closure and disables the R RELAY.

3.4.2. Repeat Input Manual Ringdown Mode

When the distant station applies ringing on the 2-wire facility, the ringing signal is received by the CONTROL LOGIC via the RCV A signaling bit. The CONTROL LOGIC enables the R RELAY, and ringing voltage is repeated toward the local station, via T&R, as sent by the distant station.

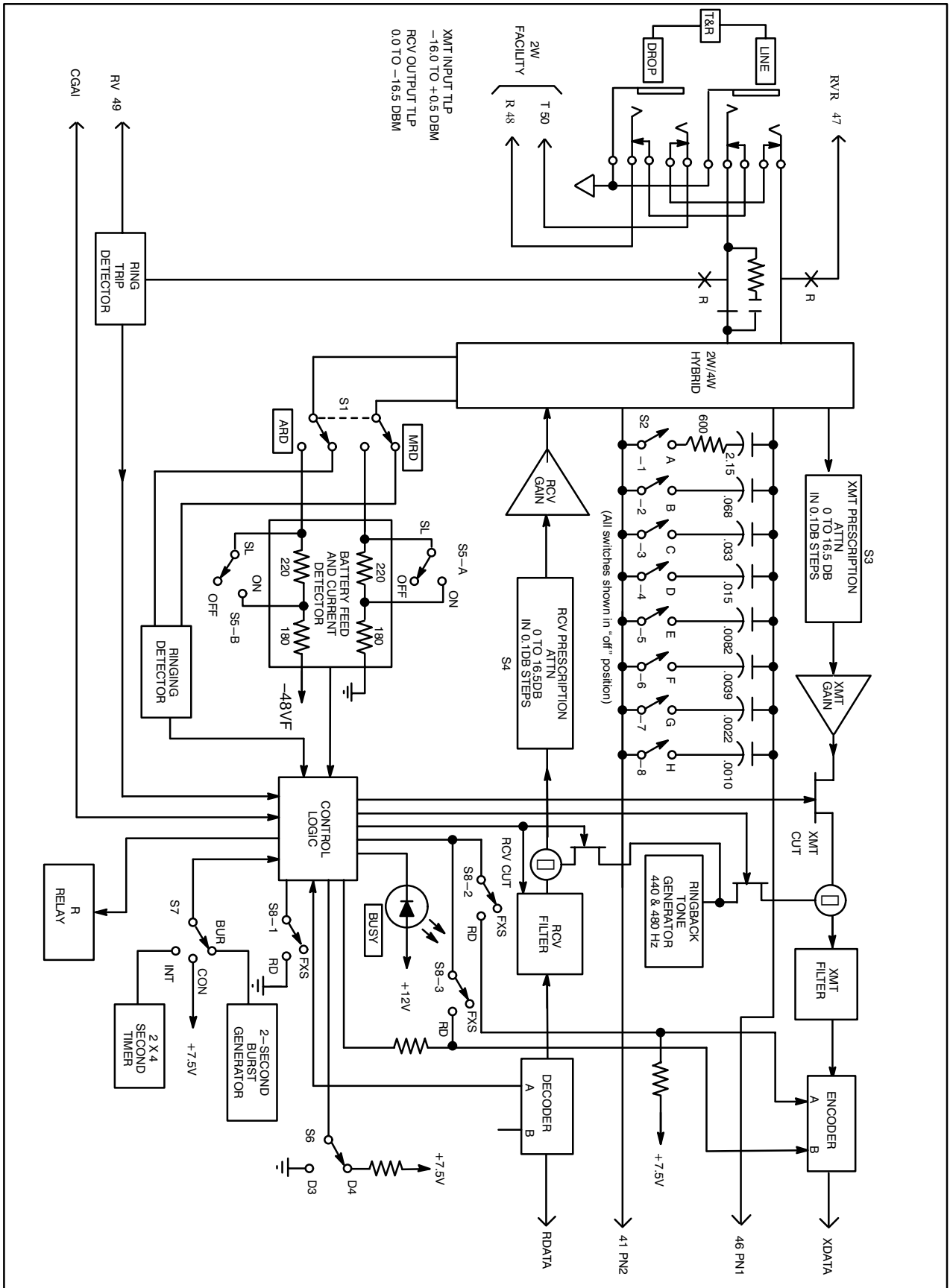

Figure 5. 3660-03 2W ARD/MRD Block Diagram

3.4.3. No Code Manual Ringdown Mode

When the distant station applies ringing on the 2-wire facility, the ringing signal is received by the CONTROL LOGIC via the RCV A signaling bit. When the distant station removes the ringing, the CONTROL LOGIC enables the 2-SECOND BURST GENERATOR (enabling the R RELAY), and a single 2-second burst of ringing is applied toward the local station.

3.5 Trunk Processing During a Carrier Group Alarm (CGA)

During a carrier failure, the CONTROL LOGIC circuit disables the Ringing Circuit.

4. INSPECTION

Inspect the equipment thoroughly upon delivery. If the equipment has been damaged in transit, immediately report the extent of damage to the transportation company.

Charles Industries equipment is identified by a model and issue number imprinted on the front panel or located elsewhere on the equipment. Each time a major engineering design change is made on the equipment, the issue number is advanced by one number on any following models that are manufactured. Therefore, be sure to include both the model number and its issue number when making inquiries about the equipment.

Each channel unit is shipped in a static-protective carton to prevent electrostatic charges from damaging CMOS devices. A unit intended for future use should be tested as soon as possible and returned to its protective carton for storage. A protective carton can be identified by a black coating on the inside. Previously, an uncoated carton was used, and the channel unit was enclosed in a black or brown static-protective plastic bag.

CAUTION

Do not ship or store modules near strong electrostatic, electromagnetic, or magnetic fields. Use the original static-protective packaging for shipping or storage.

5. MOUNTING

CAUTION

Removal and installation of modules should be done with care. Do not force a module into place. If excessive resistance is encountered while installing a module, remove the module and check the card guide and connector to verify proper alignment and the absence of foreign material.

Align the channel unit with the appropriate card-guided slot of the terminal. With the front panel in a horizontal (up) position, slide the unit into the slot. When the top portion of the hinged front panel is under the front lip of the terminal, push down on the front panel until it is in the vertical position. The channel unit's card-edge connector will begin to make contact with the inner portion of the backplane connector. Continue applying light pressure onto the bottom edge of the front panel until the unit snaps into place.

6. INSTALLER CONNECTIONS

Installer connections are made to the channel unit by wire-wrapping leads onto the associated 50-pin connectors located on the backplane assembly of the 360/363 D4 terminal. On connectorized 360/363 D4 terminals (360–10, –11, etc.) connections are made via 25-pair female connectors (CINCH 222–22–50–023 or equivalent) to the appropriate 25-pair male connectors of the 360/363 D4 terminal.

7. OPTIONS

The 3660–03 is equipped with DIP and slide switches that are used to condition the module for proper application and operation. Refer to Figure 6 for the location of these options while reading the following instructions.

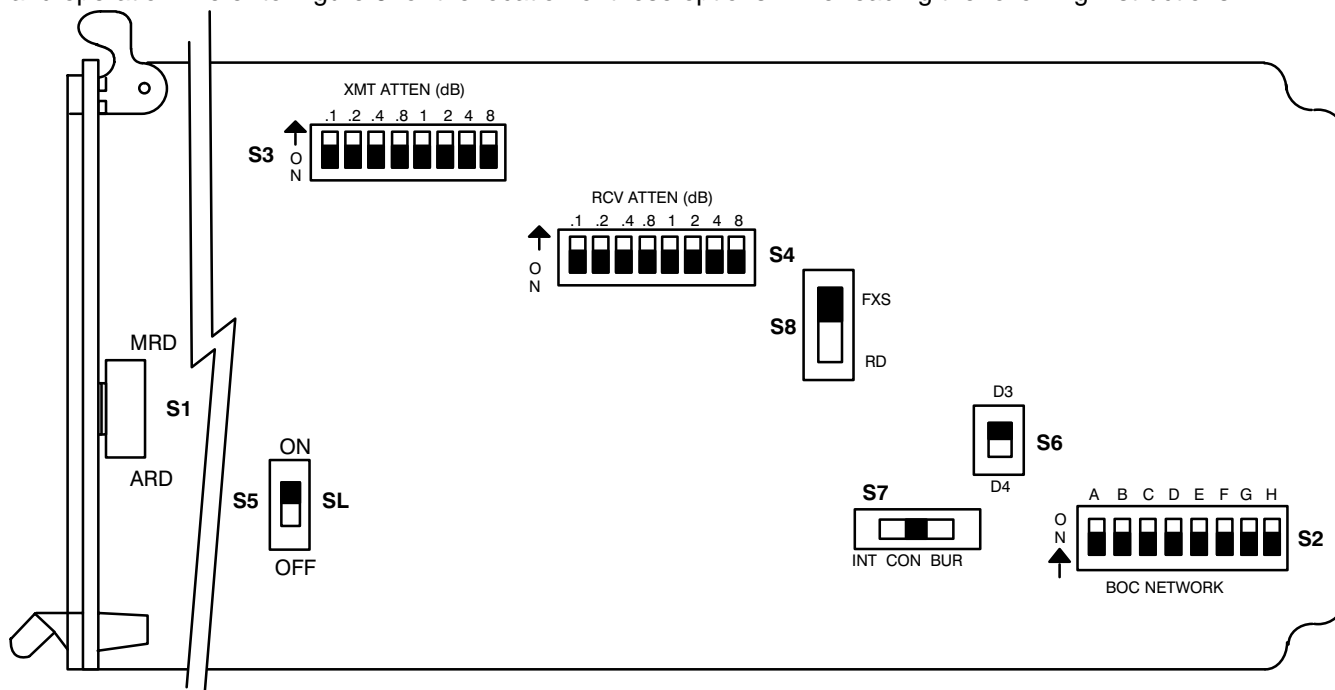

Figure 6. 3660–03 (Issue 2) Option Locations

7.1 Ringdown Signaling Mode, Switches S1, S6, S7 and S8

These switches configure the unit for one of the four possible ringdown modes. Set these switches per Table 1.

Table 1. Mode Selection

Mode	S1	S6	S7	S8
ARD NORMAL	ARD	See Note	INT	RD
ARD FXS	ARD	D3	INT	FXS
MRD NO CODE	MRD	D4	BUR	RD
MRD REPEAT INPUT	MRD	D4	CON	RD

Note: If the far-end unit uses D3 ARD signaling, set S6 to D3; if the far-end unit uses D4 ARD signaling, set S6 to D4.

7.2 2W XMT (input) Level Adjustment, Switch S3

Switch S3 is an eight-section DIP switch that is used to set the 2W XMT (input) TLP levels between -16.0 and $+0.5$ dBm. To adjust the transmit path to a given TLP, switch S3 is set to a value that equals the difference between -16 and the TLP. For example, to set the input TLP to a -1.5 dBm, switch S3 would be set for a total of 14.5 dB by placing the 8, 4, 2, 0.4 and 0.1 sections in the ON position.

7.3 2W RCV (output) Level Adjustment, Switch S4

Switch S4 is an eight-section DIP switch that is used to set the 2W receive (output) TLP levels between -16.5 and 0.0 dBm. To adjust the receive path to a given TLP, switch S4 is set to a value that equals the difference between 0 and the TLP. For example, to set the output TLP to a -1.5 dBm, switch S4 would be set for a total of 1.5 dB by placing the 1, 0.4 and 0.1 sections in the ON position.

7.4 Switch S5–SL ON, OFF (Short Loop)

For a short-loop length (below 300 ohms), set S5 to the OFF position. If the loop length is 300 ohms or greater, set S5 to the ON position.

7.5 Switch S2 Hybrid Balance Impedance

Switch S2 is an eight-section DIP switch used for selecting the appropriate amount of capacitance required for balancing the 2W/4W hybrid circuit. Hybrid balance can also be provided by an external compromise network or PBN via pins 46 and 41 (PN1 and PN2, respectively).

7.5.1. Switch S2-A (Compromise Balance Network) (CBN)

Switch S2–A is used to select a compromise balance network of 600 ohms in series with a 2.15uF capacitor. To select this option, set switch S2–A to ON.

7.5.2. Switches S2–B Through S2–H (Build-Out Capacitance) (BOC)

Switches S2–B through S2–H provide up to 0.1313uF BOC for balancing the hybrid circuitry relative to the line connected to the 2-wire port of the 3660–03. By placing the individual switches to the ON position, the required amount of capacitance can be added in approximately 0.001uF increments.

8. TESTING

Place a call end-to-end through the facility to verify proper operation. If trouble is encountered, recheck all installer connections, options and alignment settings, and verify that the channel unit is making positive connection to the backplane connector. If trouble persists, replace the unit with a similar unit known to be in proper operating order, and retest the facility. Channel unit testing for fault diagnosis or verification of circuit operation is provided in Section 360–001–205.

9. TECHNICAL ASSISTANCE

9.1 Technical Assistance — U.S.

If technical assistance is required, contact Charles Industries' Technical Services Center at:

847–806–8500

847–806–8556 (FAX)

800–607–8500

techserv@charlesindustries.com (e-mail)

9.2 Technical Assistance — Canada

Canadian customers contact:

905–821–7673 (Main Office)

905–821–3280 (FAX)

10. WARRANTY & CUSTOMER SERVICE

10.1 Warranty

Charles Industries, Ltd. offers an industry-leading, 5-year warranty on products manufactured by Charles Industries. Contact your local Sales Representative at the address or telephone numbers below for warranty details. The warranty provisions are subject to change without notice. The terms and conditions applicable to any specific sale of product shall be defined in the resulting sales contract.

Charles Industries, Ltd.
5600 Apollo Drive
Rolling Meadows, Illinois 60008–4049

Telephone: 847–806–6300 (Main Office)
847–806–6231 (FAX)

10.2 Field Repairs (In-Warranty Units)

Field repairs involving the replacement of components within a unit are not recommended and may void the warranty and compatibility with any applicable regulatory or agency requirements. If a unit needs repair, contact Charles Industries, Ltd. for replacement or repair instructions, or follow the *Repair Service Procedure* below.

10.3 Advanced Replacement Service (In-Warranty Units)

Charles Industries, Ltd. offers an “advanced replacement” service if a replacement unit is required as soon as possible. With this service, the unit will be shipped in the fastest manner consistent with the urgency of the situation. In most cases, there are no charges for in-warranty repairs, except for the transportation charges of the unit and for a testing and handling charge for units returned with no trouble found. Upon receipt of the advanced replacement unit, return the out-of-service unit in the carton in which the replacement was shipped, using the pre-addressed shipping label provided. Call your customer service representative at the telephone number above for more details.

10.4 Standard Repair and Replacement Service (Both In-Warranty and Out-Of-Warranty Units)

Charles Industries, Ltd. offers a standard repair or exchange service for units either in- or out-of-warranty. With this service, units may be shipped to Charles Industries for either repair and quality testing or exchanged for a replacement unit, as determined by Charles Industries. Follow the *Repair Service Procedure* below to return units and to secure a repair or replacement. A handling charge applies for equipment returned with no trouble found. To obtain more details of this service and a schedule of prices, contact the CI Service Center at 217–932–5288 (FAX 217–932–2943).

Repair Service Procedure

1. Prepare, complete, and enclose a purchase order in the box with the equipment to be returned.
2. Include the following information:
 - Company name and address
 - Contact name and phone number
 - Inventory of equipment being shipped
 - Particulars as to the nature of the failure
 - Return shipping address
3. Ship the equipment, purchase order, and above-listed information, transportation prepaid, to the service center address shown below.

CI Service Center
Route 40 East
Casey, IL 62420–2054
4. Most repaired or replaced units will be returned within 30 or 45 days, depending on the product type and availability of repair parts. Repaired units are warranted for either 90 days from the date of repair or for the remaining unexpired portion of the original warranty, whichever is longer.

11. SPECIFICATIONS

11.1 Electrical

The electrical characteristics of the 3660–03 (Issue 2) are as follows:

11.1.1. Transmission

- (a) 2-WIRE IMPEDANCE: 600 ohms + 2.15uF.
- (b) TRANSMIT (INPUT) TLP RANGE: –16 to +0.5 dBm
- (c) RECEIVE (OUTPUT) TLP RANGE: –16.5 to 0.0 dBm
- (d) LONGITUDINAL BALANCE: 58.0dB minimum at 200Hz to 1kHz; 53dB minimum at 3kHz (referenced to –16dBm TLP).
- (e) SIGNAL TO DISTORTION RATIO: 35dB minimum at 0.0 to –30dBm0; 29dB minimum at –40dBm0; 25dB minimum at –45dBm0.
- (f) TRANS-HYBRID LOSS: SRL 20dB, ERL 34dB.
- (g) RETURN LOSS: SRL 20dB minimum; ERL 28dB.
- (h) TRANSMIT/RECEIVE IDLE CHANNEL NOISE: 20dBmC0 maximum.
- (i) LEVEL TRACKING (MEASURED SINGLE- ENDED at 1010Hz): ± 0.25 dB from +3 to –37dBm0, ± 0.5 dB from –38 to –50dBm0.
- (j) FREQUENCY RESPONSE (REFERENCED AT 1kHz):

Frequency (Hz)	XMT (dB)	RCV (dB)
60	< 20.0	–
200	–3.0 to 0.25	–2.0 to 0.0
300	–0.5 to 0.25	–0.5 to 0.25
1000	0 (REFERENCE)	0 (REFERENCE)
3000	–0.5 to 0.25	–0.5 to 0.25
3400	–1.5 to 0.0	–1.5 to 0.0
4000	< –14.0	< –14.0

- (k) –48V CURRENT DRAW: Idle, 20mA; busy, 35mA.

11.1.2. Signaling

- (l) RINGING SENSITIVITY: 65 Vrms at 20Hz.
- (m) LOOP CLOSURE DETECT: Detect, less than or equal to 2k ohms; no detect, greater than or equal to 10k ohms.
- (n) RINGBACK TONE: 440Hz + 480Hz.
- (o) RINGBACK TONE LEVEL: Less than –14dBm0.
- (p) INTERRUPTED RINGING: Ringing period, 2 ± 0.3 seconds; silent period, 4 ± 0.5 seconds.
- (q) 2-SECOND BURST RINGING: 2 ± 0.3 seconds.
- (r) SIGNALING RANGE: 2000-ohm loop.
- (s) 20Hz RINGING RANGE: 2000-ohm loop.

11.2 Physical

The physical characteristics of the 3660–03 (Issue 2) are as follows in Table 2.

Table 2. Physical Specifications

Feature	U.S.	Metric
Height	4.25 inches	10.8 cm
Width	1.31 inches	3.3 cm
Depth	10.31 inches	26.2 cm
Weight	1 lb.	454 kg
Temperature	32° to 122° F	0 to 50° C.
Humidity	To 95% (no condensation)	

