

3659-00 2-Wire Duplex (2W DX) Channel Unit

 Recognized under Underwriters Laboratories Standard 1459, Second Edition*

| CONTENTS | PAGE |
|--|------|
| Part 1. GENERAL | 2 |
| Part 2. INSPECTION | 2 |
| Part 3. APPLICATION GUIDELINES | 3 |
| Part 4. CIRCUIT DESCRIPTION | 3 |
| Part 5. MOUNTING | 6 |
| Part 6. INSTALLER CONNECTIONS | 7 |
| Part 7. OPTIONS | 7 |
| Part 8. ALIGNMENT | 9 |
| Part 9. TESTING | 10 |
| Part 10. TECHNICAL ASSISTANCE | 10 |
| Part 11. WARRANTY & CUSTOMER SERVICE | 10 |
| Part 12. SPECIFICATIONS | 11 |

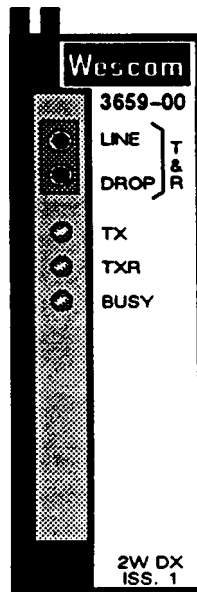

Figure 1. 3659-00 2W DX Channel Unit

1. GENERAL

1.1 Document Purpose

This document provides information on the Charles 3659–002–Wire Duplex (2W DX) Channel Unit, shown in Figure 1.

***CAUTION**

Field repairs/modifications may void compliance with Underwriters Laboratories Standard 1459 – 2nd Edition. Compliance is restricted to inside plant wiring.

1.2 Document Status

This document is reprinted to include a general editorial update.

1.3 Equipment Function

The 3659–00 channel unit is used in the Charles 360/363 D4 Digital Carrier Terminal to provide an interface to special service circuits.

1.4 Equipment Location/Mounting

Occupies one channel unit slot of a Charles 360/363 D4 Digital Carrier Terminal Channel Bank Assembly.

1.5 Equipment Features

- Complies with AT&T Publication 43801
- Termination impedance of 900 ohms in series with 2.15uF
- Built-in hybrid-balancing compromise network of 900 ohms in series with 2.15uF, selectable
- Built-in jack (J3) to mount an optional 3690–10 Compromise Network Subassembly or an optional 3690–11, –12, or –13 Precision Balance Network Subassembly, and provisions (pins 41 and 46) to connect an external PBN
- Built-in jacks (J2 and J4) to mount optional 3691–00 Nonloaded Cable Equalizer and/or 3691–01 H88 Loaded Cable Equalizer Subassemblies for post- and/or pre-equalization
- DX line-balancing resistors and capacitors
- Immediate-idle or delayed-busy trunk processing during carrier failure, selectable
- Transmit and receive prescription attenuation of 16.5dB, in 0.1dB increments
- Front-panel BUSY LED indicator
- Front-panel-accessible pin-jack test points (TX and TXR) for monitoring the transmit level
- Front-panel-accessible bantam breaking-jacks for accessing the distant (line) or local (drop) end
- Recognized under Underwriters Laboratories Standard 1459, Second Edition

2. INSPECTION

2.1 Inspect for Damages

Inspect the equipment thoroughly upon delivery. If the equipment has been damaged in transit, immediately report the extent of damage to the transportation company.

2.2 Equipment Identification

Charles Industries' equipment is identified by a model and issue number imprinted on the front panel or located elsewhere on the equipment. Each time a major engineering design change is made on the equipment, the issue number is advanced by 1 and imprinted on subsequent units manufactured. Therefore, be sure to include both the model number and its issue number when making inquiries about the equipment.

2.3 Static Concerns

Each module is shipped in static-protective packaging to prevent electrostatic charges from damaging static-sensitive devices. Use approved static-preventive measures, such as static-conductive wrist straps and a static-dissipative mat, when handling modules outside of their protective packaging. A module intended for future use should be tested as soon as possible and returned to its original protective packaging for storage.



STATIC-SENSITIVE

This equipment contains static-sensitive electronic devices. To prevent electrostatic charges from damaging static-sensitive units:

- Use approved static preventive measures (such as a static-conductive wrist strap and a static-dissipative mat) at all times whenever touching units outside of their original, shipped static-protective packaging.
- Do not ship or store units near strong electrostatic, electromagnetic, or magnetic fields.
- Use static-protective packaging for shipping or storage.

3. APPLICATION GUIDELINES

The 3659–00 provides a direct interface between 2-wire metallic facilities using DX signaling circuits and the common equipment units of a 360/363 D4 terminal. DX signaling provides simultaneous signaling in both directions and is generally used in PBX tie trunks and toll-connecting trunks with metallic facilities that do not exceed five kilohms of loop resistance.

The 3659–00 provides electronic DX signaling on one end (see Figure 2) of a metallic facility; the other end of the metallic facility must be terminated in the appropriate DX signaling equipment, electronic or electromechanical.

The distant end of the carrier facility can be terminated typically in any one of the following channel unit types: 2W DX, 4W DX, 2W E&M, 4W E&M, 4W PLR, or 4W USF.

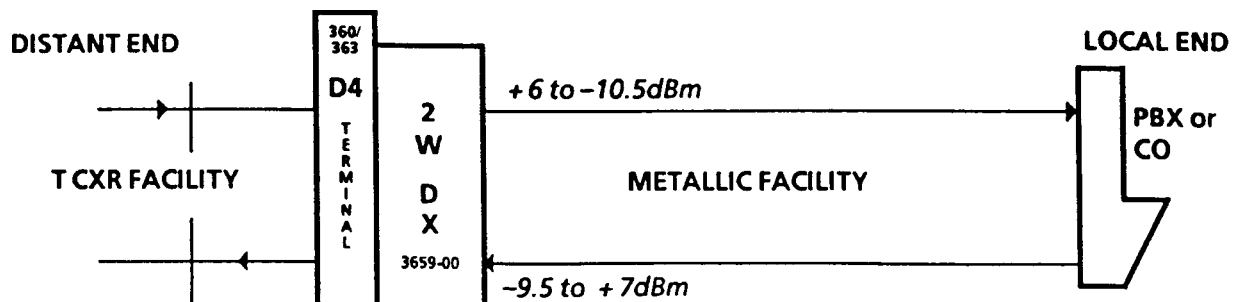

Figure 2. 3659–00 2W DX Channel Unit Typical Application

4. CIRCUIT DESCRIPTION

Refer to the block diagram in Figure 3 while reading the following circuit description.

4.1 Transmit VF Path

Voice Frequency (VF) signals applied to the input T&R leads (pins 50 and 48) are routed through the DROP and LINE breaking-jacks to transformer T1. In turn, transformer T1 provides DC isolation from the metallic facility and accepts input signals from -9.5 to $+7$ dBm. After passing through the 2W/4W HYBRID, the VF signals are routed to the XMT GAIN circuit. The circuit provides signal amplification, and is factory adjusted to compensate for

losses in the transformer and filters. The equalizer subassembly, in conjunction with XMT GAIN, provides amplitude post-equalization for nonloaded or loaded cable.

From the XMT GAIN circuit, signals pass to the XMT ATTN circuit, which is adjusted to provide the proper signal level to the ENCODER. Adjustment is accomplished by push-on jumper options that provide attenuation in the following steps: 0.1, 0.2, 0.4, 0.8, 1, 2, 4, and 8dB. By selecting appropriate steps, any attenuation value between 0.1 and 16.5dB, in 0.1dB increments, can be obtained.

The adjusted VF signal is then applied to the XMT FILTER for suppression of frequencies that are outside the bandwidth of the standard voice frequency and prevents them from entering the ENCODER.

The filtered VF signal is then applied to the ENCODER. The ENCODER performs an Analog-To-Digital (A/D) conversion of the VF signal and sends the resulting PCM signal to the 360/363 D4 terminal common equipment via the XDATA lead.

4.2 Receive VF Path

The PCM signals from the RDATA lead are sent to the DECODER where a Digital-To-Analog (D/A) conversion takes place. The resultant analog signal is then sent to the RCV FILTER.

The output of the DECODER is applied to the RCV FILTER circuit. The RCV FILTER reconstructs the transmitted waveform from the stair step output of the DECODER; additionally it suppresses frequencies above 4kHz.

From the RCV FILTER, signals pass to the RCV ATTN circuit, which is adjusted to provide the required output level at the 2-wire pair. Adjustment is accomplished via push-on jumper options which provide attenuation in the following steps: 0.1, 0.2, 0.4, 0.8, 1, 2, 4, and 8dB. By selecting appropriate steps, any attenuation value between 0.1 and 16.5dB, in 0.1dB increments, can be obtained. The output of the RCV ATTN is forwarded to the RCV GAIN circuit. The equalizer subassembly, in conjunction with RCV GAIN, provides amplitude pre-equalization for nonloaded or loaded cable. Without the optional equalizer subassembly the RCV GAIN provides the proper output at the T&R leads when a + 5.2dBm signal is present at the decoder output.

The output of the RCV GAIN circuit is applied to the 2W/4W HYBRID, which contains an inverting and a noninverting operational amplifier. The inverting amplifier's output is coupled through transformer T1 to the 2-wire pair, while the noninverting amplifier's output is applied to the hybrid-balance circuitry. The resulting signals from both amplifiers are nulled at the input of the transmit amplifier circuitry.

4.3 Signaling

In the transmit direction, the 3659–00 converts unbalanced conditions across the metallic facility into signaling levels that are multiplexed with the outgoing PCM data. In the receive direction, signaling information is demultiplexed from the incoming PCM data and converted into unbalanced conditions across the metallic facility.

The reference voltage for the DX BRIDGE & DRIVER CIRCUIT is provided by the REFERENCE SUPPLY. The DETECTOR CIRCUIT converts the DX signaling states to logic levels for application to the ENCODER signaling inputs. There is 4uF midpoint capacitance across the A&B leads to reduce switching transients. The C BAL capacitors and R BAL resistors are provided to balance the line capacitance and resistance. Capacitance or resistance is added to the circuit by screw options MC, NC, SC, TC, UC, VC, and WC.

4.4 Transmit Signaling

When the distant DX station is idle (on-hook), its DX set keeps the metallic facility (see Figure 2) balanced. In this condition, the DETECTOR circuit sends an idle condition to the A and B signaling inputs of the ENCODER which, in turn, transmits it to the distant end of the T carrier indicating that the distant DX station is idle.

When the distant DX station is busy (off hook), the metallic facility becomes unbalanced. This condition is detected across the DX BRIDGE by the DETECTOR circuit, which in turn, forwards this busy condition to the A and B signaling inputs of the ENCODER. The ENCODER then transmits the busy signal to the distant end of the T carrier indicating that the distant DX station is busy.

4.5 Receive Signaling

Receive signaling, from the distant end of the T carrier, is demultiplexed from the incoming PCM bit stream and controls the status of the A signaling output of the DECODER. When idle, the A signaling output is logic 1; the S RELAY CIRCUIT is inactive and the metallic facility is balanced. When the level at the A signaling output is logic 0 (busy condition), the S RELAY CIRCUIT operates (via the RELAY DRIVER). This causes the BUSY LED to illuminate and the 5 RELAY CIRCUIT contacts to reverse state which removes ground and transfers –48V to the DX BRIDGE thereby unbalancing the metallic facility. This indicates a busy condition to the distant DX station.

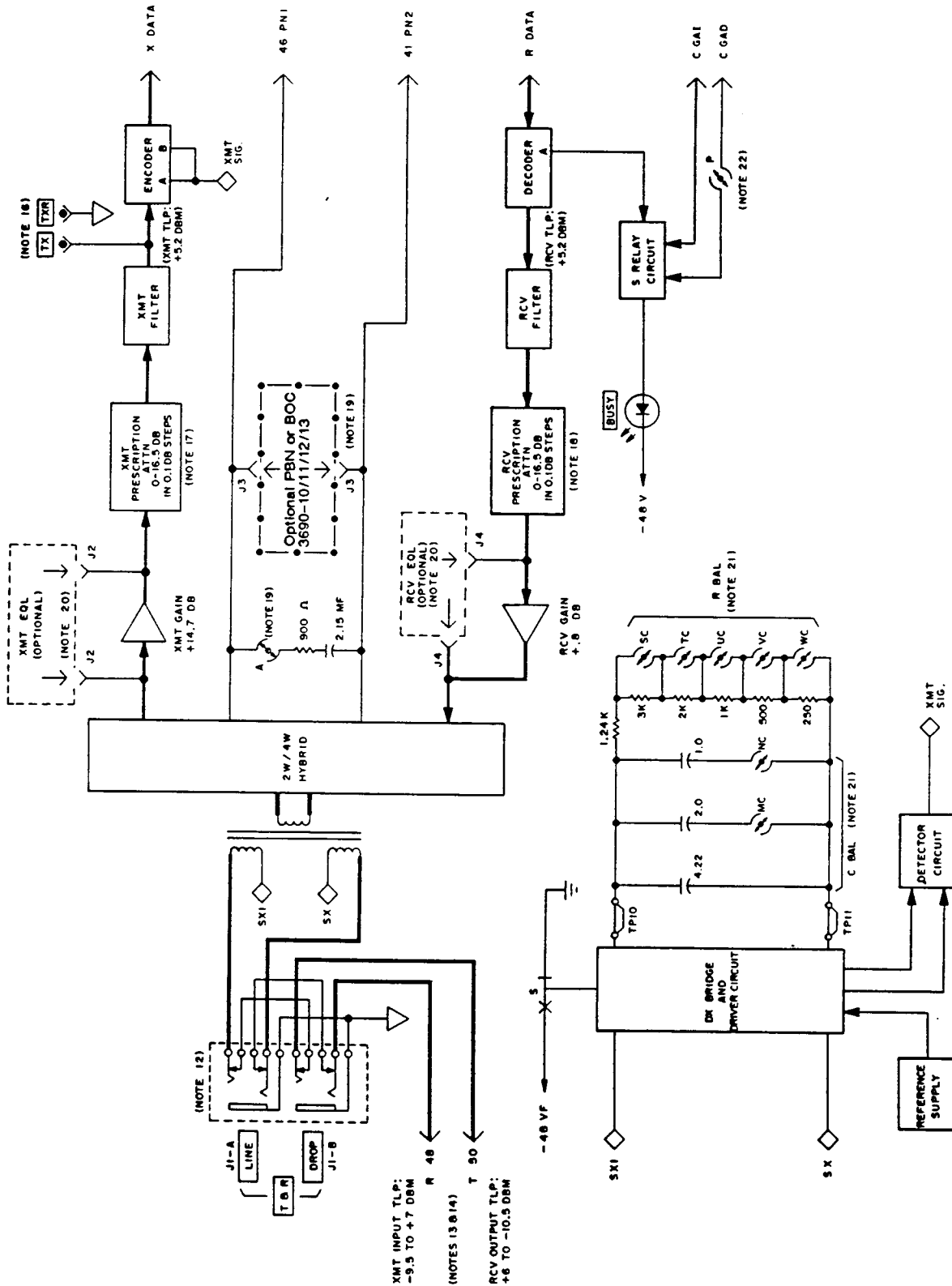

Figure 3. 3659-00 2W DX Channel Unit (Issue 1) Block Diagram

Table 1. Notes for the Block Diagram

NOTES:

1. CONNECTOR.
2. PRIMARY TRANSMISSION PATH.
3. PC MOUNT TEST POINT.
4. SIGNAL FLOW DIRECTION.
5. N.O., N.C. RELAY CONTACTS.
6. FRONT PANEL MARKING.
7. OPTIONAL CIRCUIT ENCLOSURE.
8. RECEPTACLE TYPE OPTIONAL STRAP.
9. ALTERNATE POSITION.
9. OPEN, CLOSED SCREW OPTION.
10. COIL TYPE TEST POINT.
11. GANGED SWITCHES ARE INDICATED BY DASHED CONNECTION LINE OR SUFFIXED REF. DESIG.
12. PC MOUNT TEST JACKS:

| MARKING | FUNCTION |
|------------------|---------------------------------|
| T&R LINE (J1-A) | ACCESS TOWARDS CHANNEL UNIT |
| T&R DROP (J1-B) | ACCESS TOWARDS OFFICE EQUIPMENT |
| TX&TXR (TP3&TP4) | 4 WIRE XMT MONITOR |

13. THE XMT INPUT RANGE AT T & R :
+7DBM TO -9.5DBM. THE UNIT IS FACTORY ADJUSTED FOR 0DBM INPUT. THE XMT ATTEN IS SET FOR 9.5DB ATTENUATION.
14. THE RCV OUTPUT RANGE AT T & R :
+6DBM TO -10.5DBM. THE UNIT IS FACTORY ADJUSTED FOR -3DBM OUTPUT. THE RCV ATTEN IS SET FOR 9DB ATTENUATION.
15. ALL LIKE-DESIGNATED POINTS ARE CONNECTED.
16. THE LEVEL AT THE TRANSMIT UNBALANCED MONITOR POINTS TX-TXR, MEASURED WITH A BRIDGED METER SHOULD BE +5.2DBM ± 0.1DBM.
17. THE XMT ATTEN PROVIDES 16.5DB ATTENUATION IN 0.1DB STEPS TO ACCOMMODATE INPUT RANGE OF FROM +7DBM TO -9.5DBM WITH -9.5DBM INPUT, NO ATTENUATION IS NEEDED. WHEN INPUT GOES UP, AN APPROPRIATE AMOUNT OF ATTENUATION IS ADDED SUCH THAT THE LEVEL AT TX-TXR IS MAINTAINED AT ±5.2DBM ± 0.1DB.
18. THE RCV ATTEN PROVIDES 16.5DB ATTENUATION IN 0.1DB STEPS TO ACCOMMODATE OUTPUT RANGE OF FROM +6DBM TO -10.5DBM. FOR +6DBM OUTPUT LEVEL, NO ATTENUATION IS NEEDED. AN APPROPRIATE AMOUNT OF ATTENUATION IS ADDED WHEN LOWER OUTPUT LEVEL IS REQUIRED.

19. 3690-10/11/12/13 PBN/BOC ARE ORDERED SEPARATELY AND USED WHEN INSERTED INTO CONNECTOR J3. OPEN OPTION A WHEN PBN/BOC IS USED.
20. A91-369100 NON-LOADED CABLE EQUALIZER OR A91-369101 LOADED CABLE EQUALIZER ARE ORDERED SEPARATELY TO PROVIDE POST-EQUALIZATION WHEN INSERTED INTO CONNECTOR J2, AND PRE-EQUALIZATION WHEN INSERTED INTO CONNECTOR J4.
- 21.

| DX LINE BAL | CLOSE OPTION | OPEN OPTION |
|---|--------------|-------------|
| CAPACITOR | 4 | MC,NC |
| | 5 | NC |
| | 6 | MC |
| | 7 | NC,MC |
| TOTAL VALUE (UF) | | |
| RESISTOR INCR VALUE (OHMS) | 250 | SC,TC,UC,VC |
| | 500 | SC,TC,UC,VC |
| | 1K | SC,TC,VC,WC |
| | 2K | SC,UC,VC,WC |
| 3K | WC,UC,VC,TC | SC |
| IT IS NOT NECESSARY TO ADD 1250 OHM WHEN COMPUTING TOTAL DX RESISTANCE. | | |

22. DURING CARRIER FAILURE, ALARM OPTION P CAN BE CONFIGURED FOR:
 - a) CONTINUOUS IDLE : OPEN P (CGAI)
 - b) TWO SECONDS IDLE, FOLLOWED BY CONTINUOUS BUSY FOR THE DURATION OF CARRIER FAILURE : CLOSE P (CGAD).

4.6 Trunk Processing During A Carrier Group Alarm (CGA)

Upon carrier failure, the CGAI bus goes to ground, which causes the S RELAY CIRCUIT to be immediately disabled causing a call in progress to be dropped. If screw option P is set in the open position, the S RELAY CIRCUIT will remain deactivated (idle condition) during the period of the carrier failure. However, if screw option P is set in the closed position, the CGAD bus will reactivate the S RELAY CIRCUIT, after approximately 2 seconds, forcing a busy condition during the period of the carrier failure.

5. MOUNTING

The 3659-00 mounts in one channel unit slot of a 360/363 D4 terminal. The 3659-00 is equipped with an insert/eject lever in the form of a hinged front panel which ensures a positive connection of the channel unit's card-edge connector to the backplane connector when the unit is installed. The insert/eject lever also facilitates removal of the unit.

CAUTION

Removal and installation of modules should be done with care. Do not force a module into place. If excessive resistance is encountered while installing a module, remove the module and check the card guide and connector to verify proper alignment and the absence of foreign material.

| Step | Action |
|------|--|
| 1. | Align the channel unit with the appropriate card-guided slot of the terminal. |
| 2. | Slide the unit into the slot with the front panel in a horizontal (up) position. |
| 3. | When the top portion of the hinged front panel is under the front lip of the terminal, push down on the front panel until it is in the vertical position. The channel unit's card edge connector will begin to make contact with the inner portion of the backplane connector. |
| 4. | Continue applying light pressure onto the bottom edge of the front panel until the unit snaps into place. |

6. INSTALLER CONNECTIONS

Installer connections are made to the 3659–00 channel unit by wire-wrapping to the T&R (pins 50&48) leads, and as required the PN1&PN2 (pins 46&41) leads of the associated 50 pin connectors located on the back-plane assembly of a non-connectorized 360/363 D4 terminal. On connectorized 360/363 D4 terminals (360–10, –1 1, etc.) connections for T&R are made via 25-pair female connectors (CINCH 222–22–50–023 or equivalent) to the appropriate 25-pair male connectors of the 360/363 D4 terminal. Refer to Section 360–000–200 for the wiring diagrams of the female connectors with respect to the 360/363 D4 terminal being utilized. Electrical connections are made when the unit is installed; PN 1 & PN2 are not connectorized.

7. OPTIONS

The following paragraphs describe the options that are used to condition the 3659–00 for proper application and operation. Also refer to Figure 4 for a drawing showing the option locations and a brief summary of the option conditioning requirements.

Note: When opening a screw option, rotate the screw counterclockwise two full turns to ensure that the connection is open. When closing a screw option, rotate the screw clockwise until it seats.

7.1 DX Resistive Matching Network Screw Options SC, TC, UC, VC, WC

Screw options SC, TC, UC, VC, and WC are used to provide resistive line balance. Condition the resistive line balance network of the 3659–00 according to Table 2 and the following:

- Determine the loop resistance of the facility.
- Select resistors with a total value equal to the calculated loop resistance \pm 125 ohms. Place the desired resistors into the matching network by opening the required screw options.

Example:

1. Calculate the loop resistance: 1500 ohms.
2. The required matching network resistance is: 1500 ± 125 ohms.
3. Open screw options UC and VC per Table 2. Make sure that screw options SC, TC, and WC are closed.

Note: Some DX signaling units require 1250 ohms to be added to the loop resistance when calculating the balance resistance. The 3659–00 2W DX contains a balance network which compensates for this 1250 ohms. When calculating the required balance resistance, do not add 1250 ohms to the loop resistance values.

7.2 DX Capacitance Matching Network Screw Options MC, NC

Screw options MC (2uF) and NC (1uF) provide additional capacitance matching to minimize pulse distortion resulting from a capacitance mismatch between the trunk facility and the DX network. Closing the option adds its capacitance to the 4.22uF capacitor (see block diagram) while opening the option removes its capacitance from

the balancing network. In most cases, satisfactory operation will be achieved by closing MC and opening NC which results in 6.22uF balancing capacitance.

7.3 Trunk Processing Screw Option P

Option P conditions the 3659–00 for different trunk processing sequences. The DX channel unit idles immediately upon the occurrence of a Carrier Group Alarm (CGA). With option P open, the 3659–00 will remain idle until the CGA clears. With option P closed, the 3659–00 will be idled for 2.5 seconds upon the occurrence of a CGA and then be busied for the duration of the CGA.

Table 2. Resistive Line Balance Network

| Open Position of Screw | Adds Resistance of |
|-------------------------------|---------------------------|
| SC | 3 kilohms |
| TC | 2 kilohms |
| UC | 1 kilohm |
| VC | 500 ohms |
| WC | 250 ohms |

7.4 Hybrid Balance Screw Option A

The 3659–00 can accept an internal PBN or BOC via connector J3 or an external PBN or BOC via pins 46 and 41 (PNI and PN2, respectively). Option A conditions the 3659–00 for use with an optional PBN or SOC. When using an optional PSN or BOC, open option A. When an optional PBN or BOC is not being used, close option A which then selects the on-board compromise network of 900 ohms in series with 2.15uF.

7.5 Jack J2–Post-Equalization

A Charles 3691–00 Nonloaded Cable Equalizer Subassembly or 3691–01 H88 Loaded Cable Equalizer Subassembly can be ordered separately to provide post-equalization (transmit path) when inserted into jack J2. Additional information on the 3691–00/01 is available in Section 369–100–201.

7.6 Jack J3–Comp Net/PBN-Hybrid Balancing

A Charles 3690–10, –11, –12, or –13 Sub-assembly can be ordered separately and inserted into jack J3 to provide hybrid balancing. See Figure 4 for the available Sections on the 3690–XX Subassemblies.

7.7 Jack J4 – Pre-Equalization

A Charles 3691–00 Nonloaded Cable Equalizer Subassembly or 3691–01 H88 Loaded Cable Equalizer Subassembly can be ordered separately to provide pre-equalization (receive path) when inserted into jack J4. Additional information on the 3691–00/01 is available in Section 369100–201.

7.8 XMT Attenuation Push-On Jumpers

Eight push-on jumpers select the appropriate amount of attenuation between zero and 16.5dB in 0.1dB increments for adjusting the transmit path to the proper operating level. By placing the individual jumpers (0.1, 0.2, 0.4, 0.8, 1, 2, 4, 8dB) to the IN positions, as required, the desired level of + 5.2dBm at the TX and TXR test points can be achieved. With all of the jumpers in the OUT positions, 0dB attenuation is achieved.

7.9 RCV Attenuation Push-On Jumpers

Eight push-on jumpers select the appropriate amount of attenuation between zero and 16.5dB in 0.1dB increments for adjusting the receive path to the proper operating level. By placing the individual jumpers (0.1, 0.2, 0.4, 0.8, 1, 2, 4, 8dB) to the IN positions, as required, the desired output level can be achieved. With all of the jumpers in the OUT positions, 0dB attenuation is achieved.

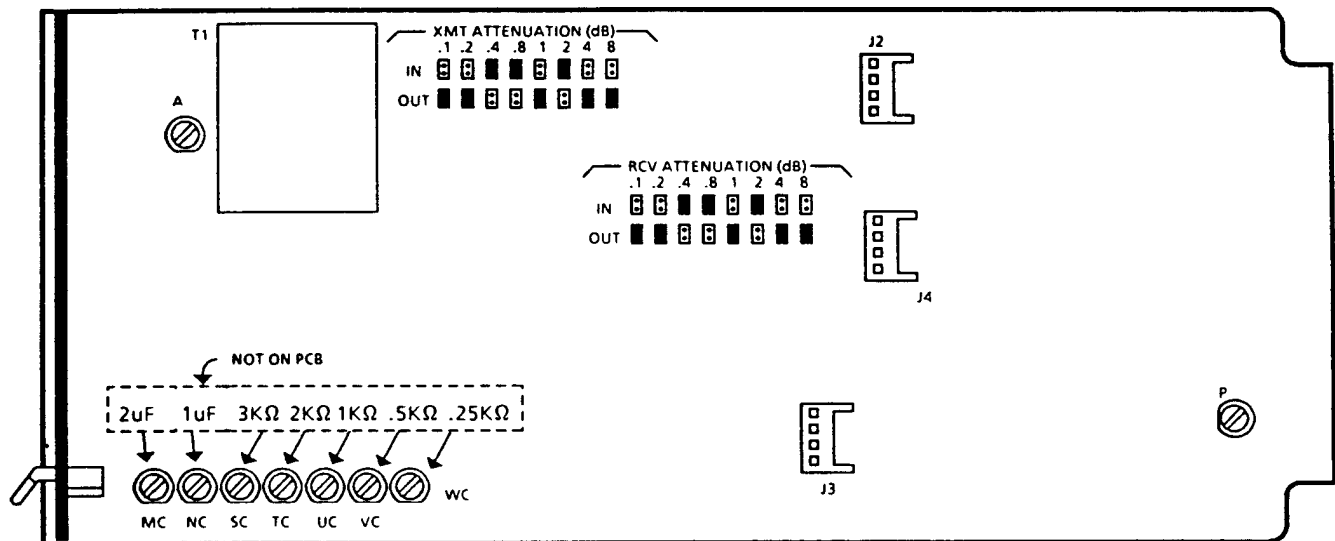

Figure 4. 3659–00 2W DX Channel Unit (issue 1) Option Locations

Table 3. 3659–00 2W DX Channel Unit (issue 1) Option Description

| Option | Function/Remarks | Position |
|--------------------|--|---|
| J2 | Jack for mounting an optional transmit post-equalizer 3691–00/01. | See Section 369–100–201 |
| J3 | Jack for mounting optional Comp Net/PBN 3690–10, –11,–12, or –1 3. | See Section 369–010–201, 369–011–201, 369–012–201, or 369–013–201 |
| J4 | Jack for mounting an optional receive pre-equalizer 3691–00/01. | See Section 369–100–201 |
| RCV ATTEN | Eight push-on jumpers (0.1,0.2,0.4,0.8,1,2,4,8) total 16.5dB of receive attenuation when all are in the IN positions. | See paragraph 8.2 |
| XMT ATTEN | Eight push-on jumpers (0.1,0.2,0.4,0.8,1,2,4,8) total 16.5dB of transmit attenuation when all are in the IN positions. | See paragraph 8.1 |
| A | Set to the OPEN position if jack J3 is equipped or if an external PBN/BOC is used. | OPEN/CLOSED |
| P | CLOSED gives idle from start of carrier failure, changing to busy 2 seconds later. OPEN gives continuous idle during carrier failure. | CLOSED OPEN |
| MC, NC | DX line balancing capacitors; set to CLOSED to add MC = 2uF, NC = 1 uF. | See paragraph 7.2 |
| SC, TC, UC, VC, WC | DX line balancing resistors; set to OPEN to add required resistance. | See paragraph 7.1 |

8. ALIGNMENT

8.1 Transmit Alignment

The XMT ATTENUATION push-on jumpers are a prescription control that provides attenuation from 0 to 16.5dB in increments of 0.1dB to accommodate an input TLP range from –9.5 to + 7dB. To adjust the transmit path to the proper operation level, the difference between –9.5dBm and the transmit TLP at T&R must be obtained.

$$[XMT\ ATTN = (TLP) - (-9.5)]$$

For an input TLP of -2dBm , the XMT ATTN = $(-2) - (-9.5) = 7.5\text{dB}$. Set the sum of the XMT ATTN jumpers in the ON position to 7.5dB .

8.2 Receive Alignment

The RCV ATTENUATION push-on jumpers are a prescription control that provides attenuation from 0 to 16.5dB in increments of 0.1dB to accommodate an output TLP range from $+6.0$ to -10.5dB . To adjust the receive path to the proper operation level, the difference between $+6\text{dBm}$ and the receive TLP at T&R must be obtained.

$$[\text{RCV ATTN} = +6 - (\text{TLP})\text{L}]$$

For an output TLP of -1dBm , the RCV ATTN = $+6 - (-1) = 7\text{dB}$. Set the sum of the RCV ATTN jumpers in the ON position to 7dB .

9. TESTING

After completing Part NO TAG through Part 8., place a call end-to-end through the facility to verify proper operation. If trouble is encountered, re-check all installer connection, options and alignment settings, and verify that the channel unit is making positive connection to the backplane connector. If trouble persists, replace the unit with a similar unit known to be in proper operating order and retest the facility. Channel unit testing for fault diagnosis or verification of circuit operation is provided in Section 360–001–205.

10. TECHNICAL ASSISTANCE

If technical assistance is required, contact Charles Industries' Technical Services Center at:

847–806–8500

847–806–8556 (FAX)

800–607–8500

techserv@charlesindustries.com (e-mail)

11. WARRANTY & CUSTOMER SERVICE

11.1 Warranty

Charles Industries, Ltd. offers an industry-leading, 5-year warranty on products manufactured by Charles Industries. Contact your local Sales Representative at the address or telephone numbers below for warranty details. The warranty provisions are subject to change without notice. The terms and conditions applicable to any specific sale of product shall be defined in the resulting sales contract.

Charles Industries, Ltd.

5600 Apollo Drive

Rolling Meadows, Illinois 60008–4049

847–806–6300 (Main Office)

847–806–6231 (FAX)

11.2 Field Repairs (In-Warranty Units)

Field repairs involving the replacement of components within a unit are not recommended and may void the warranty and compatibility with any applicable regulatory or agency requirements. If a unit needs repair, contact Charles Industries, Ltd. for replacement or repair instructions, or follow the *Repair Service Procedure* below.

11.3 Advanced Replacement Service (In-Warranty Units)

Charles Industries, Ltd. offers an “advanced replacement” service if a replacement unit is required as soon as possible. With this service, the unit will be shipped in the fastest manner consistent with the urgency of the situation. In most cases, there are no charges for in-warranty repairs, except for the transportation charges of the unit and for a testing and handling charge for units returned with no trouble found. Upon receipt of the advanced replacement unit, return the out-of-service unit in the carton in which the replacement was shipped, using the pre-addressed shipping label provided. Call your customer service representative at the telephone number above for more details.

11.4 Standard Repair and Replacement Service (Both In-Warranty and Out-Of-Warranty Units)

Charles Industries, Ltd. offers a standard repair or exchange service for units either in- or out-of-warranty. With this service, units may be shipped to Charles Industries for either repair and quality testing or exchanged for a replacement unit, as determined by Charles Industries. Follow the *Repair Service Procedure* below to return units and to secure a repair or replacement. A handling charge applies for equipment returned with no trouble found. To obtain more details of this service and a schedule of prices, contact the CI Service Center at 217–932–5288 (FAX 217–932–2943).

Repair Service Procedure

1. Prepare, complete, and enclose a purchase order in the box with the equipment to be returned.
2. Include the following information:
 - Company name and address
 - Contact name and phone number
 - Inventory of equipment being shipped
 - Particulars as to the nature of the failure
 - Return shipping address
3. Ship the equipment, purchase order, and above-listed information, transportation prepaid, to the service center address shown below.

CI Service Center
503 N.E. 15th St., P.O. Box 339
Casey, IL 62420–2054
4. Most repaired or replaced units will be returned within 30 or 45 days, depending on the product type and availability of repair parts. Repaired units are warranted for either 90 days from the date of repair or for the remaining unexpired portion of the original warranty, whichever is longer.

12. SPECIFICATIONS

The electrical single ended characteristics of the 3659–00 2W DX Channel Unit (Issue 1) are as follows:

- (a) PERMISSIBLE MODES: 2T9–4T, 4T–2T9
- (b) TRANSMIT INPUT TLP RANGE: –9.5 to + 7dBm.
- (c) RECEIVE OUTPUT TLP RANGE: –10.5 to + 6dBm.
- (d) TRANSMIT PRESCRIPTION ATTENUATION: Zero to 16.5dB in increments of 0.1dB.
- (e) RECEIVE PRESCRIPTION ATTENUATION: Zero to 16.5dB in increments of 0.1dB.
- (f) 2W PORT IMPEDANCE: 900 OHMS + 2.15uF.
- (g) LINE SIDE LEVELS: Transmit (fixed) 5.2 TLP; Receive (fixed) 5.2 TLP
- (h) LONGITUDINAL BALANCE: –62dB or less at 200Hz to 1 kHz; –60dB or less at 3kHz.
- (i) SIGNAL TO DISTORTION RATIO: 35dB minimum at zero to –30dBm0; 29dB minimum at –40dBm0; 25dB minimum at –45dBm0.
- (j) TRANS-HYBRID LOSS: Echo return loss, 36dB minimum; singing return loss, 25dB minimum; singing return loss high, 36dB minimum.
- (k) TRANSMIT AND RECEIVE PATH FREQUENCY RESPONSE (Referenced At 1 kHz):

| FREQUENCY (Hz) | XMT (dB) | RCV (dB) |
|----------------|-----------------|-----------------|
| 60 | –20 minimum | — |
| 200 | –2.5 to + 0.15 | –1.5 to +0.15 |
| 300 | –0.49 to + 0.24 | –0.49 to + 0.24 |
| 1000 | 0 (Reference) | 0 (Reference) |
| 3000 | –0–.49 to +0.24 | –0–.49 to +0.24 |
| 3400 | 0 to – 1.2 | 0 to – 1.2 |
| 4000 | –14 minimum | –14 minimum |
| 5100 | –32 minimum | –28 minimum |

- (l) RETURN LOSS: Echo return loss, 35dB minimum; singing return loss, 23dB minimum; singing return loss high, 32dB minimum.
- (m) TRANSMIT/RECEIVE IDLE CHANNEL NOISE: 20dBmC0 maximum.
- (n) CROSSTALK: 61dBm0 minimum at 400Hz, 7dBm0 minimum at 700Hz to 1 kHz, 70dBm0 minimum at 3 kHz.
- (o) LEVEL TRACKING (Measured Single-Ended At 1010Hz): ± 0.25 dB from + 3 to –37dBm0, ± 0.5 DB from –38 to –50dBm0.
- (p) OPERATING ENVIRONMENT: Temperature, 32° to 122° F (0° to 50° C).
- (q) CURRENT DRAIN: Typical from –48VDC: idle, 35mA; busy, 40mA.

12.1 Signaling

- (a) LINE RESISTANCE: 5,000 ohms maximum.

12.2 Physical

The physical characteristics of the 3659–00 2W DX Channel Unit (Issue 1) are shown in Table 4:

Table 4. Physical Specifications

| Feature | U.S. | Metric |
|------------------|-------------|------------------|
| Height | 4.3 inches | 10.9 centimeters |
| Width | 1.36 inches | 3.5 centimeters |
| Depth | 10.4 inches | 26.4 centimeters |
| Weight (nominal) | 20 ounces | 570 grams |

