

3658-03 4-Wire Foreign Exchange Office (4W FXO) LS/GS and 3658-07 4W FXO LS Only Channel Units

CONTENTS	PAGE
Part 1. GENERAL	2
Part 2. INSPECTION	2
Part 3. APPLICATION GUIDELINES	3
Part 4. CIRCUIT DESCRIPTION	3
Part 5. MOUNTING	9
Part 6. INSTALLER CONNECTIONS	9
Part 7. OPTIONS	9
Part 8. ALIGNMENT	13
Part 9. TECHNICAL ASSISTANCE	13
Part 10. WARRANTY & CUSTOMER SERVICE	13
Part 11. SPECIFICATIONS	14

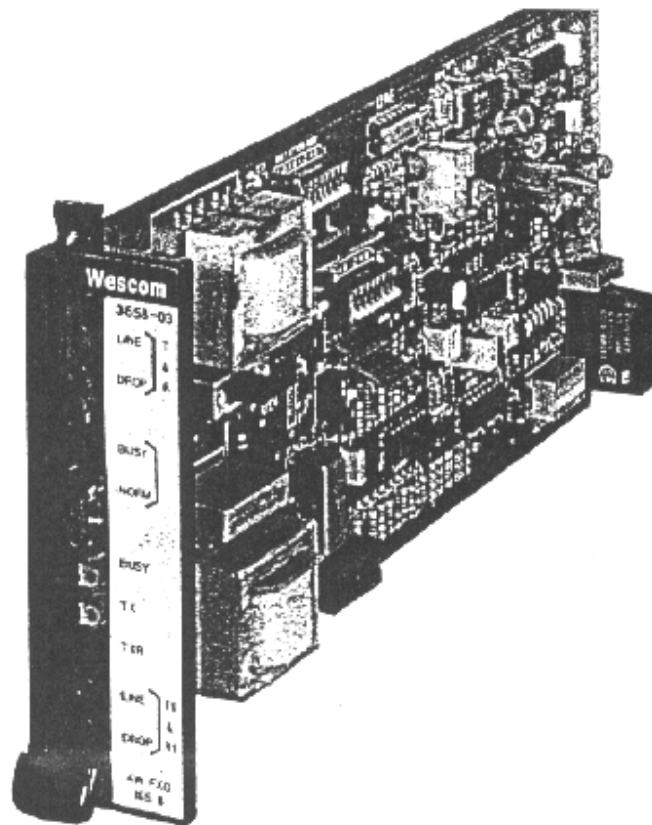

Figure 1. 3658-03 (Issue 6) 4W FXO Channel Unit

1. GENERAL

1.1 Document Purpose

This document provides information on the issue 6 version of the Charles 3658–03 and 365807 4-Wire Foreign Exchange Office (4W FXO) Channel Units.

1.2 Document Status

This document is reprinted to include a general editorial update.

1.3 Equipment Function

The channel units are used in the Charles 360/363 D4 Digital Carrier Terminal to provide an interface to special service circuits. The channel units differ in their carrier failure alarm features (shown in Figure 8). The 3658–03 is shown in Figure 1.

1.4 Equipment Location/Mounting

Occupies one channel unit slot of a Charles 360/363 D4 Digital Carrier Channel Bank Assembly.

1.5 Equipment Features

The 3658–03 and 3658–07 features include the following:

- Complies with AT&T Publication 43801 Specifications
- Switch-selectable termination impedance of 150, 600, 1200 ohms for matching the 4-wire port interface
- Prescription attenuation for the transmit and receive levels
- Front-panel-accessible bantam breaking-jacks for accessing the transmit and receive ports
- Front-panel-accessible pin-jack test points (TX and TXR) for monitoring the transmit level
- Front-panel-accessible NORM/BUSY switch
- Front-panel BUSY LED indicator
- Jack to mount an optional 3691–00 Nonloaded Cable Equalizer or 3691–01 H88 Loaded Cable Equalizer Subassembly for post-equalization
- Compatible with DID, D3, and D4FXS channel units
- SX lead normal-reverse switch for tandem operation with a 4W FXS channel unit in an intermediate office
- Automatic trunk processing and lead conditioning via optionable Ring Ground (RG)(except 3658–07), Trunk Processing (TP), and Loop Closure (LC) relays during carrier failure
- Build-out resistance of 400 ohms for loops less than 1.1k ohms
- Compatible with 100-millisecond ringing intervals
- Switch-selective ground-start or loop-start operation (3658–03 only)

2. INSPECTION

2.1 Inspect for Damages

Inspect the equipment thoroughly upon delivery. If the equipment has been damaged in transit, immediately report the extent of damage to the transportation company.

2.2 Equipment Identification

Charles Industries' equipment is identified by a model and issue number imprinted on the front panel or located elsewhere on the equipment. Each time a major engineering design change is made on the equipment, the issue number is advanced by 1 and imprinted on subsequent units manufactured. Therefore, be sure to include both the model number and its issue number when making inquiries about the equipment.

2.3 Static Concerns

Each module is shipped in static-protective packaging to prevent electrostatic charges from damaging static-sensitive devices. Use approved static-preventive measures, such as static-conductive wrist straps and a static-dissipative mat, when handling modules outside of their protective packaging. A module intended for future use should be tested as soon as possible and returned to its original protective packaging for storage.



STATIC-SENSITIVE

This equipment contains static-sensitive electronic devices. To prevent electrostatic charges from damaging static-sensitive units:

- Use approved static preventive measures (such as a static-conductive wrist strap and a static-dissipative mat) at all times whenever touching units outside of their original, shipped static-protective packaging.
- Do not ship or store units near strong electrostatic, electromagnetic, or magnetic fields.
- Use static-protective packaging for shipping or storage.

3. APPLICATION GUIDELINES

The 3658–03 or the 3658–07 4W FXO together with the common equipment units of the 360/363 D4 terminal provides a switch selectable 150/600/1200 ohm balanced interface between a T1 line and a 4-wire PBX/CO line. The 3658–03 is optional for either loop-start or ground-start operation. The 3658–07 is loop-start only. Refer to Figure 2 for typical application.

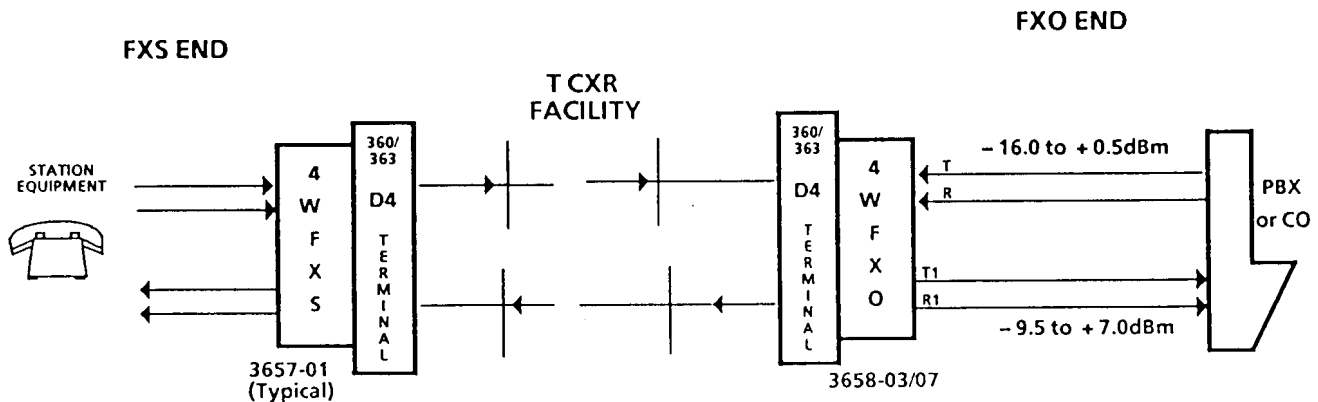

Figure 2. 3658-03 And 3658-07 4W FXO Typical Application

4. CIRCUIT DESCRIPTION

Refer to the appropriate block diagram (Issue 6) while reading the following circuit description; Figure 3 (3658–03), or Figure 5 (3658–07),

4.1 Transmit VF Path

Voice Frequency (VF) transmission from the 4-wire facility appears at T and R (pins 50 and 48) and is routed through the DROP and LINE breaking-jacks to XMT TRANSFORMER. The XMT TRANSFORMER provides a switchable (S6) impedance of 150, 600, or 1200 ohms for matching the impedance of the metallic facility. The XMT TRANSFORMER also provides DC isolation on the line.

Voice energy from XMT TRANSFORMER is routed into the XMT GAIN and XMT PRESCRIPTION ATTEN circuits. These circuits, acting together, set the transmit path gain to the exact level required to drive the XMT FILTER and ENCODER circuits. The use of the XMT PRESCRIPTION ATTEN allows for a range of office TLPs from –16 to +0.5dBm in 0.1dB increments.

Jack J3 is provided for accepting a plug-in optional equalizer subassembly for post-equalization in the transmit path. The Charles 3691–00 Nonloaded Cable Equalizer or 3691–01 H88 Loaded Cable Equalizer can be ordered separately. Refer to Sections 369–100–201 for additional information on these equalizers.

The output of the XMT GAIN circuit is applied to the XMT FILTER for suppression of frequencies that are outside the bandwidth of the standard voice frequency and prevents them from entering the ENCODER.

The filtered VF signal is then applied to the ENCODER. The ENCODER performs an Analog-To-Digital (A/D) conversion of the VF signal and sends the resulting Pulse Code Modulation (PCM) signal to the 360/363 D4 terminal common equipment via the XDATA lead.

4.2 Receive VF Path

The PCM digital signal transmitted from the far-end is received by the 360/363 D4 terminal common equipment and in turn is routed to the 3658–03/07 via the RDATA lead. The DECODER and RCV FILTER then, in turn, perform a Digital-To-Analog (D/A) conversion of the signal and suppression of frequencies that are outside the bandwidth of the standard voice frequency.

The output of the RCV FILTER is applied to the RCV GAIN and RCV PRESCRIPTION ATTEN circuits which acting together, set the receive path gain to the exact level required to interface with a range of office TLPS. The use of the RCV PRESCRIPTION ATTEN allows for an output level from +7 to–9.5dBm in 0.1dB increments.

The output of the RCV PRESCRIPTION ATTEN circuit is coupled through RCV TRANSFORMER, switch S6, and the LINE and DROP breaking-jacks (J2–A and J2–B) to T1 & R1. S6 selects terminating impedance of 150, 600, or 1200 ohms, to match the impedance of the metallic facility and to provide a balanced output for the RCV TRANSFORMER. The RCV TRANSFORMER provides DC isolation from the line.

4.3 Transmit Signaling

The 3658–03, when optioned for ground-start operation, transmits ringing or tip ground information onto the digital facility. The 3658–07, being loop-start only, transmits only ringing information onto the digital facility. The 3658–03 can be optioned for loop-start operation by placing S10 to the LS position. Signaling states transmitted toward the digital facility are multiplexed onto the digital facility by the ENCODER.

4.4 3658–03 Only

A ground applied to the T&R leads is detected by the RINGING AND TIP GROUND DETECTOR circuit. The 3658–03 will then transmit this tip-ground condition to the ENCODER where it will be multiplexed onto the A highway of the T CXR facility.

4.5 3658–03 And 3658–07

When the RINGING AND TIP GROUND DETECTOR circuit (RINGING DETECTOR circuit for the 3658–07) senses ringing on the T1 & R1 leads, the ringing condition will be multiplexed onto the B highway of the digital facility.

4.6 3658–03 Only

The RINGING AND TIP GROUND circuit senses an on- or off-hook condition by detecting the presence of loop current. This status is sent along the A highway.

4.7 Receive Signaling

Signaling information received from the digital facility is sent through the DECODER to the RG RELAY (3658–03/43 only) and the LC RELAY. The 3658–07 being loop-start only, sends signaling information toward the metallic facility through the LC RELAY only.

4.8 3658–03 Only

A ring-ground signal from the far-end is output by the DECODER on its B lead causing the RG RELAY to operate thereby grounding the T1 & R1 leads (S5 in the NORM position).

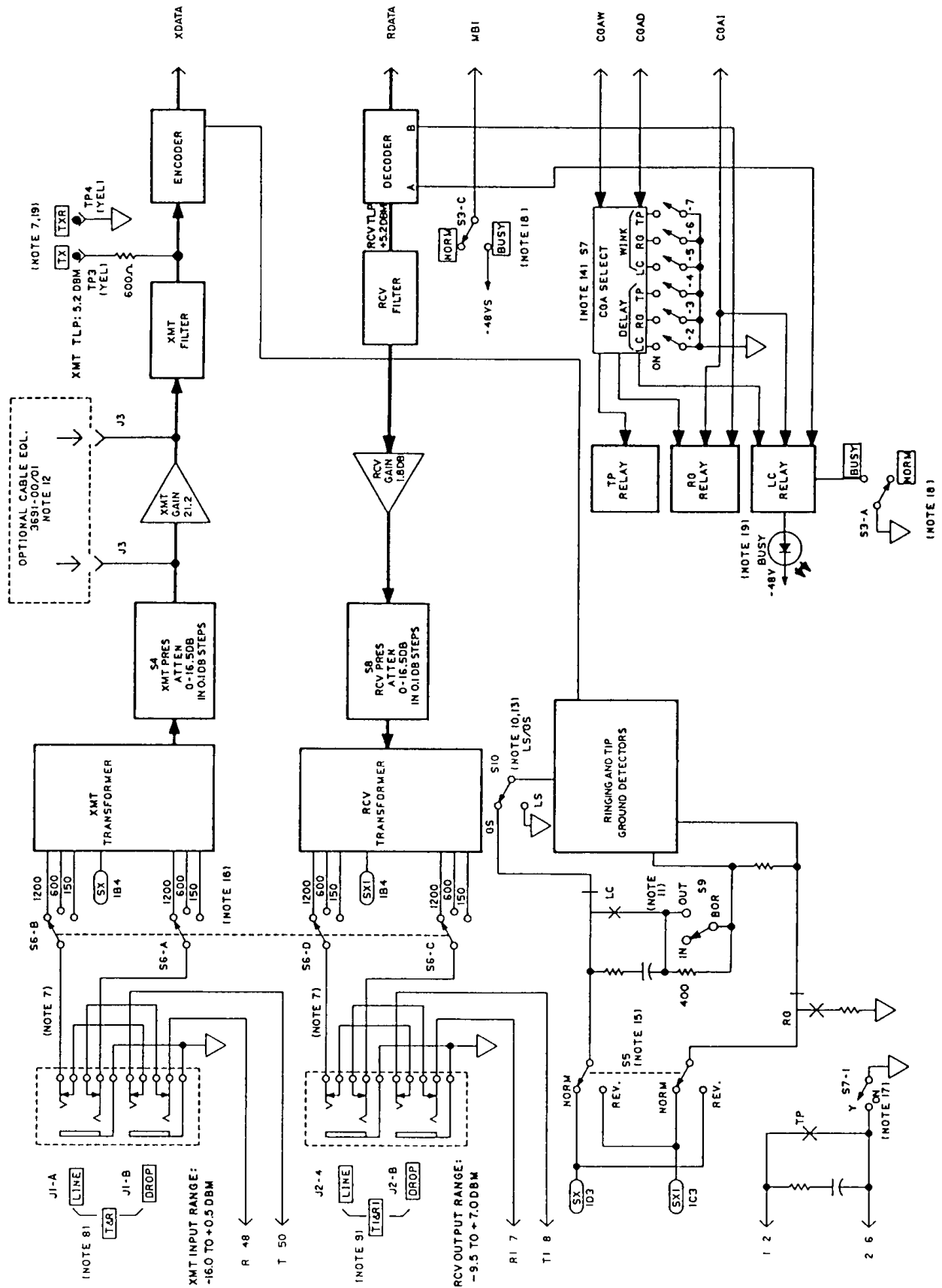







Figure 3. 3658-03 4-Wire Foreign Exchange Office (4W FXO) LS/GS Block Diagram (Sheet 1 of 2)

NOTES:

1.  PC BOARD CONNECTOR PIN.
2.  FRONT PANEL MARKING.
3.  SIGNAL FLOW DIRECTION.
4.  N.O., N.C. RELAY CONTACT
5.  TEST POINT.
6. GANGED SWITCHES ARE INDICATED BY DASHED CONNECTION LINE OR ALPHABETICALLY SUFFIXED REFERENCE DESIGNATIONS; NUMERICAL SUFFIX DENOTES DISCRETE SWITCH WITHIN A PACKAGE.
7. PC MOUNT TEST JACKS

MARKING	FUNCTION
T&R LINE (J1-A)	XMT ACCESS TOWARD CHANNEL UNIT
T&R DROP (J1-B)	XMT ACCESS TOWARD OFFICE EQUIPMENT
Ti&Ri LINE (J2-A)	RCV ACCESS TOWARD CHANNEL UNIT
Ti&Ri DROP (J2-B)	RCV ACCESS TOWARD OFFICE EQUIPMENT
TX&TXR (TP3&TP4)	4 WIRE XMT MONITOR POINTS

8. THE XMT INPUT RANGE AT T & R IS -16.0 TO +0.5 DBM. THE XMT ATTEN (S4) IS ADJUSTABLE FOR 0 TO 16.5 DB IN 0.1 DB INCREMENTS. FOR 0.0 DBM INPUT AT T & R THE XMT ATTEN SHOULD BE SET FOR 16.0 DB OF ATTENUATION.
9. THE RCV OUTPUT RANGE AT Ti&Ri IS -9.5 TO +7.0 DBM. THE RCV ATTEN (S8) IS ADJUSTABLE FOR 0 TO 16.5 DB IN 0.1 DB INCREMENTS. FOR 1.5 DBM OUTPUT AT Ti&Ri THE RCV ATTEN SHOULD BE SET FOR 5.5 DB OF ATTENUATION.
10. FOR LOOP START OPERATION PLACE THE LS/OS SWITCH (S10) IN THE LS POSITION. FOR GROUND START OPERATION PLACE S10 IN THE OS POSITION.
11. WHEN THE BOR SWITCH IS PLACED IN THE "IN" POSITION AN ADDITIONAL 400 OHMS IS PLACED IN THE LOOP. IF THE TOTAL LOOP RESISTANCE IS GREATER THAN 100 OHMS, THEN REMOVE BOR BY PLACING S9 IN THE "OUT" POSITION.
12. A91-369100 NON-LOADED CABLE EQUALIZER OR A91-369101 LOADED CABLE EQUALIZER IS ORDERED SEPARATELY TO PROVIDE POST-EQUALIZATION WHEN INSERTED IN CONNECTOR J3.
13. WHEN TESTING, SWITCHING LS/OS (S10) TO THE "LS" POSITION WILL PREVENT THE RING FROM BEING GROUNDED BY THE FAR END. RESTORE SWITCH TO PROPER SETTING AFTER TESTING.
14. DURING A CARRIER FAILURE THE UNIT SHALL FORCE NO RD AND NO LC. APPROXIMATELY 2.5 SECONDS LATER:
 - A. WITH LC-DLY (S7-2) ON (CLOSED), LC RELAY CLOSES.
 - B. WITH RD-DLY (S7-3) ON (CLOSED), RD RELAY CLOSES.
 - C. WITH TP-DLY (S7-4) ON (CLOSED), TP RELAY CLOSES.
 - D. WITH LC-WNK (S7-5) ON (CLOSED), LC RELAY WINKS OPEN.
 - E. WITH RD-WNK (S7-6) ON (CLOSED), RD RELAY WINKS OPEN.
 - F. WITH TP-WNK (S7-7) ON (CLOSED), TP RELAY WINKS OPEN.
15. SWITCH S5 PROVIDES CAPABILITY TO SWITCH SX-SXi (A-B) LEADS FROM NORMAL TO REVERSE.
16. S6 PROVIDES T&R AND Ti&Ri WITH SWITCHABLE IMPEDANCE OF 1200/600/150 OHMS.
17. WHEN THE Y SWITCH (S7-1) IS ON (CLOSED), PINS 2 AND 6 GO TO GROUND APPROXIMATELY 2.5 SECONDS AFTER CARRIER FAILURE. WHEN Y IS OPEN, PIN 2 IS CONNECTED, BY RELAY TP, TO PIN 6 2.5 SECONDS AFTER CARRIER FAILURE.
18. A BUSY SWITCH HAS BEEN PROVIDED ON THE FRONT PANEL. WHEN IN THE "BUSY" POSITION: A BUSY LED IS ILLUMINATED ON THE FRONT PANEL. THE MAKE BUSY LEAD (PIN 12) GOES TO -48V AND THE LOOP CLOSURE RELAY IS CLOSED.
19. THE LEVEL AT THE TRANSMIT TEST POINT, TX & TXR, MEASURED WITH A BRIDGED METER SHOULD BE 5.2 DBM.

Figure 4. Notes for the 3658-03 4-Wire Foreign Exchange Office (4W FXO) LS/GS Block Diagram

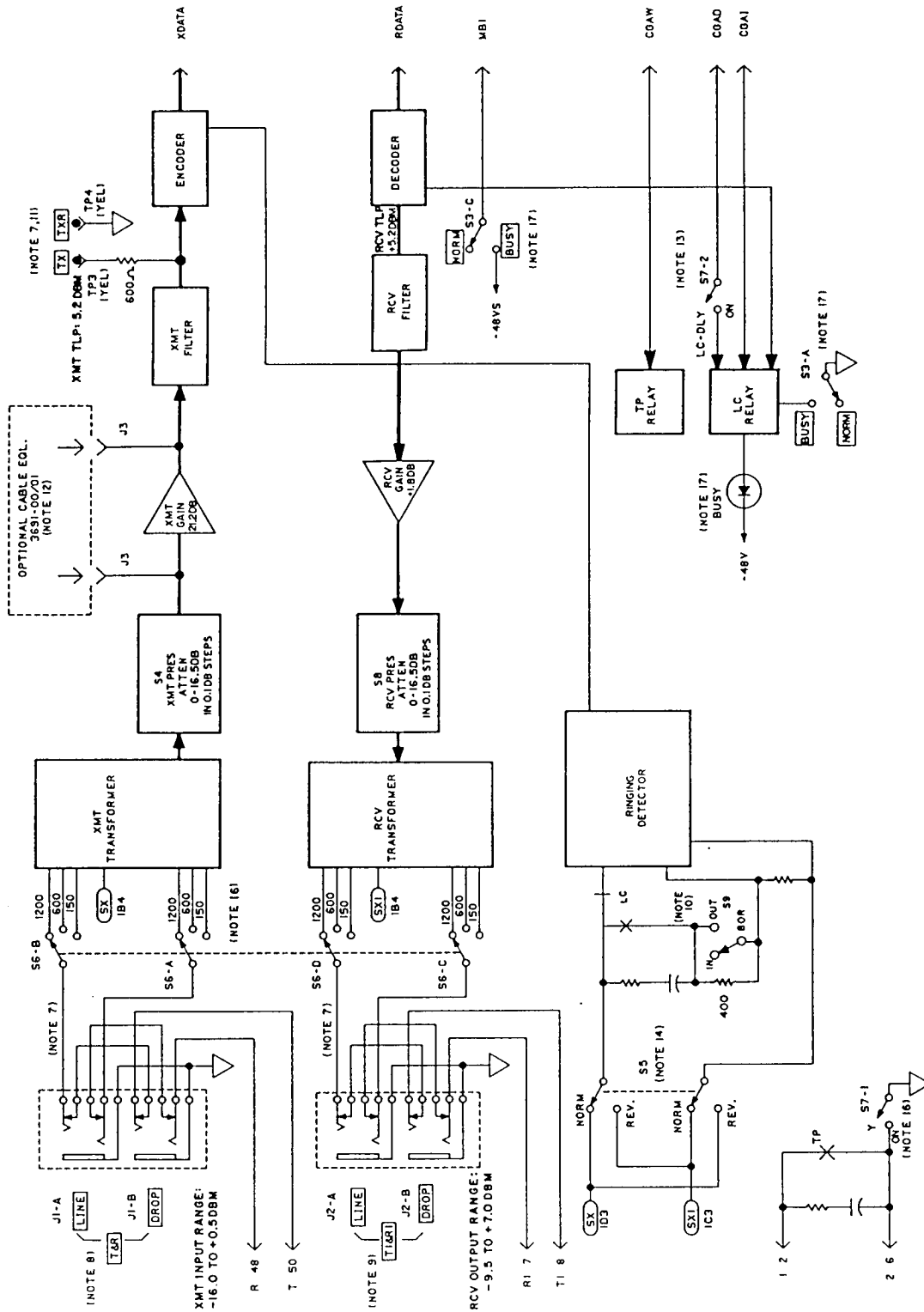

Figure 5. 3658-07 4-Wire Foreign Exchange Office (4W FXO) LS Only Block Diagram (Sheet 1 of 2)

NOTES:

1. PC BOARD CONNECTOR PIN.
2. FRONT PANEL MARKING.
3. SIGNAL FLOW DIRECTION.
4. N.O. , N.C. RELAY CONTACT.
5. TEST POINT.
6. GANGED SWITCHES ARE INDICATED BY DASHED CONNECTION LINE OR ALPHABETICALLY SUFFIXED REFERENCE DESIGNATIONS: NUMERICAL SUFFIX DENOTES DISCRETE SWITCH WITHIN A PACKAGE.
7. PC MOUNT TEST JACKS

MARKING	FUNCTION
T&R LINE (J1-A)	XMT ACCESS TOWARD CHANNEL UNIT
T&R DROP (J1-B)	XMT ACCESS TOWARD OFFICE EQUIPMENT
Ti&Ri LINE (J2-A)	RCV ACCESS TOWARD CHANNEL UNIT
Ti&Ri DROP (J2-B)	RCV ACCESS TOWARD OFFICE EQUIPMENT
TX&TXR (TP3&TP4)	4 WIRE TRANSMIT MONITOR POINTS

8. THE XMT INPUT RANGE AT T & R IS -16.0 TO +0.5 DBM. THE XMT ATTEN (S4) IS ADJUSTABLE FOR 0 TO 16.5 DB IN 0.1 DB INCREMENTS. FOR 0.0 DBM INPUT AT T & R THE XMT ATTEN SHOULD BE SET FOR 16.0 DB OF ATTENUATION.
9. THE RCV OUTPUT RANGE AT Ti&Ri IS -9.5 TO +7.0 DBM. THE RCV ATTEN (S8) IS ADJUSTABLE FOR 0 TO 16.5 DB IN 0.1 DB INCREMENTS. FOR 1.5 DBM OUTPUT AT Ti&Ri THE RCV ATTEN SHOULD BE SET FOR 5.5 DB OF ATTENUATION.
10. WHEN THE BOR SWITCH IS PLACED IN THE "IN" POSITION AN ADDITIONAL 400 OHMS IS ADDED TO THE LOOP. IF THE TOTAL LOOP RESISTANCE IS GREATER THAN 1100 OHMS, THEN REMOVE BOR BY PLACING S9 IN THE "OUT" POSITION.
11. THE LEVEL AT THE TRANSMIT TEST POINT, TX&TXR, MEASURE WITH A BRIDGE METER SHOULD BE 5.2 DBM.
12. A91-369100 NON-LOADED CABLE EQUALIZER OR A91-369101 LOADED CABLE EQUALIZER IS ORDERED SEPARATELY TO PROVIDE POST-EQUALIZATION WHEN INSERTED IN CONNECTOR J3.
13. DURING CARRIER FAILURE THE LC RELAY IS OPENED AND THE TP RELAY IS CLOSED. APPROXIMATELY 2.5 SECONDS LATER THE TP RELAY WINKS OPEN FOR 70 MS AND THE LC RELAY MAY BE OPTIONALLY CLOSED BY PLACING THE LC-DLY SWITCH (S7-2) TO ON POSITION.
14. SWITCH S5 PROVIDES CAPABILITY TO SWITCH SX-SX1 (A-B) LEADS FROM NORMAL TO REVERSE.
15. S6 PROVIDES T&R AND Ti&Ri WITH SWITCHABLE IMPEDANCE OF 1200/600/150 OHMS.
16. WHEN THE Y SWITCH (S7-1) IS ON (CLOSED) PINS 2 AND 6 GO TO GROUND APPROXIMATELY 2.5 SECONDS AFTER CARRIER FAILURE. WHEN Y IS OPEN, PIN 2 IS CONNECTED, BY RELAY TP, TO PIN 6 2.5 SECONDS AFTER CARRIER FAILURE.
17. A BUSY SWITCH (S3) IS PROVIDED ON THE FRONT PANEL. WHEN IN THE "BUSY" POSITION: A BUSY LED IS ILLUMINATED ON THE FRONT PANEL, THE MAKE BUSY LEAD (PIN 12) GOES TO -48V AND THE LOOP CLOSURE RELAY IS CLOSED.

Figure 6. Notes for 3658-07 4-Wire Foreign Exchange Office (4W FXO) LS Only Block Diagram

4.9 3658-03 And 3658-07

A loop closure signal, sent along the A highway, is output from the DECODER into the LC RELAY. Closure of this relay completes the circuit on the loop side. The BUSY LED is illuminated when the LC RELAY is operated to indicate that the channel unit is busy.

Trunk Processing During A Carrier Group Alarm (CGA)
3658-03

When a carrier failure occurs, the state of the LC RELAY, RG RELAY and the TP RELAY is determined by the setting of switch S7.

S7 DLY switches respond to Carrier Group Alarm Delay (CGAD). When one of these switches is closed, the corresponding RELAY will close approximately 2.5 seconds after carrier failure.

S7 WLK switches respond to carrier group alarm wink (CGAW). When one of these switches is closed, the corresponding RELAY will close immediately upon carrier failure. Approximately 2.5 seconds later, the RELAY will wink open for 70 milliseconds and then return to a closed state.

4.10 3658–07

When a carrier failure occurs, the TP RELAY will close and the LC RELAY will open. Approximately 2.5 seconds later, the TP RELAY will wink open for 70 milliseconds and then return to the closed state. If switch S7 LC is ON (closed) then the LC RELAY will close approximately 2.5 seconds after carrier failure.

5. MOUNTING

The 3658–03 and 3658–07 mounts in one channel unit slot of a 360/363 D4 terminal. The 3658–03 and 3658–07 are equipped with an insert/eject lever in the form of a hinged front panel which ensures a positive connection of the channel unit's card-edge connector to the backplane connector when the unit is installed. The insert/eject lever also facilitates removal of the unit.

CAUTION

Removal and installation of modules should be done with care. Do not force a module into place. If excessive resistance is encountered while installing a module, remove the module and check the card guide and connector to verify proper alignment and the absence of foreign material.

Step	Action
1.	Align the channel unit with the appropriate card-guided slot of the terminal.
2.	Slide the unit into the slot with the front panel in a horizontal (up) position.
3.	When the top portion of the hinged front panel is under the front lip of the terminal, push down on the front panel until it is in the vertical position. The channel unit's card-edge connector will begin to make contact with the inner portion of the backplane connector.
4.	Continue applying light pressure onto the bottom edge of the front panel until the unit snaps into place.

6. INSTALLER CONNECTIONS

Installer connections are made to the channel unit by wire-wrapping leads onto the associated 50-pin connectors located on the backplane assembly of the 360/363 D4 terminal. On connectorized 360/363 D4 terminals (360–10, –11, etc.) connections are made via 25-pair female connectors (CINCH 222–22–50–023 or equivalent) to the appropriate 25-pair male connectors of the 360/363 D4 terminal. Refer to Section 360–000–200 for the wiring diagrams of the female connectors with respect to the 360/363 D4 terminal being utilized. Electrical connections are made when the unit is installed.

7. OPTIONS

The following paragraphs describe the options that are used to condition the 3658–03 and 3658–07 for proper application and operation. Refer to Figure 7 (3658–03) and Figure 8 (3658–07) for locations and summary of the options.

7.1 Jack J3 –Optional Post-Equalization

A Charles 3691–00 Nonloaded Cable Equalizer Subassembly or 3691–01 H88 Loaded Cable Equalizer Subassembly can be ordered separately to provide post-equalization (transmit path) when inserted into jack J3. Additional information on the 3691–00/01 is available in Section 369–100–201.

7.2 Switch S3 – NORM/BUSY

Place switch S3 to the NORM (down) position to condition the 3658–03 and 3658–07 for normal (in-service) operation. Place S3 to the BUSY (up) position to create an out-of-service condition for testing or alignment purposes. This will also light the BUSY LED on the front panel and on the Alarm Logic Unit (ALU). The 3658–03 will also busy the channel unit at the far-end.

7.3 Switch S4 – XMT ATTEN (dB)

The prescription DIP switches on S4 are used to provide up to 16.5dB of attenuation, in 0.1dB increments. Set the appropriate switches to achieve the desired level of 5.2dBm at the TX and TXR test points.

7.4 Switch S5 – NORM/REV Simplex Leads

Place S5 to the NORM position for normal operation. For tandem operation (on 4-wire metallic facility) with an FXS, place S5 in the REV position if the 4W FXS's simplex leads are normal. Place S5 in the NORM position if the 4W FXS's simplex leads are reversed.

7.5 Switch S6 – 150/600/1200 Ohm Impedance

Set switch S6 to select the transmit and receive impedance of 150, 600, or 1200 ohms for matching the impedance of the 4-wire metallic facility.

7.6 Switch S7–2 Thru –7 – CGA Carrier Failure Alarm (3658–03)

Upon carrier failure, an immediate alarm (CGAI) opens the LC RELAY and disconnects the RG RELAY. Approximately 2.5 seconds later, when a Carrier Group Alarm Delay (CGAD) or Carrier Group Alarm Wink (CGAW) arrives, depending on how the CGA switches are set, the following occurs:

- With only S7–2 set to ON, LC RELAY closes
- With only S7–3 set to ON, RG RELAY closes
- With only S7–4 set to ON, TP RELAY closes
- With only S7–5 set to ON, LC RELAY winks
- With only S7–6 set to ON, RG RELAY winks
- With only S7–7 set to ON, TP RELAY winks

Note: Switches S7–5, –6, –7 will override switches S7–2, –3, –4 respectively.

7.7 Switch S7–1(Y) – Trunk Processing Control (3658–03)

Option S7–1 (Y) determines the state of an auxiliary set of contacts between pins 2 and 6 (lead 1 and lead 2 respectively) during trunk processing. To provide a balanced (floating) contact closure between lead 1 and lead 2, place S7–1 to the OFF position. To provide a switched ground output on the lead 1 and a ground lead 2, place S7–1 to the ON position.

7.8 Switches S7–1,–2 – CGA Carrier Failure Alarm (3658–07)

Upon carrier failure, an immediate alarm (CGAI) opens the LC RELAY and closes the TP RELAY. Approximately 2.5 seconds later, the TP RELAY winks open for 70 milliseconds. When a Carrier Group Alarm Delay (CGAD) arrives, the LC RELAY can be optionally closed by placing S7–2 (LC) to the ON position. Setting S7–1(Y) to ON provides a TP RELAY controlled ground output on the 1 Lead (pin 2). Setting S7–1 (Y) to OFF removes this ground and provides isolated contact closure between the 1 and 2 Leads.

7.9 Switch S8 – RCV ATTEN (dB)

The prescription DIP switches on S8 are used to provide up to 16.5dB of attenuation, in 0.1dB increments. Set the appropriate switches to achieve the required level at the T1 & R1 leads.

7.10 Switch S9 – Build-Out Resistor (BOR)

Set S9 to the OUT position to short-out the 400 ohm BOR resistor for loops greater than 1.1k ohms. To reduce power dissipation on shorter loops, set S9 to the IN position to add 400 ohms resistance to the loops.

7.11 Switch S10 – LS/GS, Loop Start/Ground Start (3658–03 Only)

The LS/GS option selects the proper mode of operation. To operate in the loop start mode, place switch S10 in the LS position. To operate in the ground start mode, place switch S10 in the GS position.

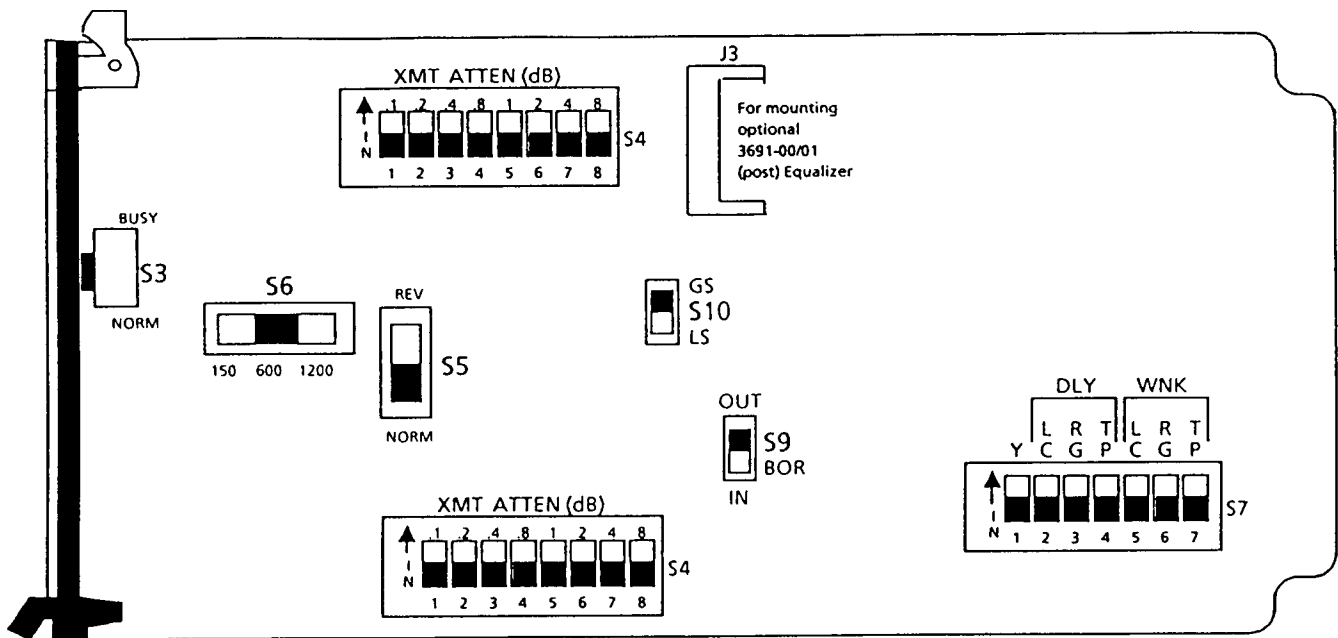

Figure 7. 3658-03 (Issue 6) Option Locations

Table 1. 3658-03 (Issue 6) Option Summary

Option	Position	Function/Remarks
J3	See Section 369-100-201	Jack for mounting an optional transmit post-equalizer (3691-00/01)
S3	NORM	For in-service operation
	BUSY	For testing or alignment
S4	See Paragraph 8.1	Provides up to 16.5dB XMT ATTEN in 0.1dB increments
S5	NORM	For normal operation
	REV/NORM (As Required)	For tandem operation, on 4-wire metallic facility, with an FXS: Place in REV position if the 4W FXS's simplex leads are normal; place in the NORM position if the 4W FXS's simplex leads are reversed
S6	150/600/1200 (as req.)	150/600/1200 ohm 4-wire metallic facility matching impedance
S7-1 (Y)	S7-1=ON	During carrier failure, leads 1 and 2 are under control of the TP RELAY; Provides switched ground output on lead 1 (pin 2)
	S7-1=OFF	Provides isolated contract closure between leads 1 (pin 2)&2 (pin 6)
S7-2 to S7-7 NOTE: S7-5, S7-6, and S7-7 override S7-2, S7-3, and S7-4 respectively	S7-2=ON S7-3=ON S7-4=ON S7-5=ON S7-6=ON S7-7=ON	Approximately 2.5 seconds after carrier failure: LC RELAY closes RG RELAY closes TP RELAY closes LC RELAY winks open RG RELAY winks open TP RELAY winks open
S8	See Paragraph 8.1	Provides up to 16.5dB RCV ATTEN in 0.1dB increments
S9 BOR	OUT	To remove 400 ohms on-board for loops greater than 1.1k ohms.
	IN	To include 400 ohms resistance for shorter loops.
S10	LS	To select loop-start mode of operation.
	GS	To select ground-start mode of operation.

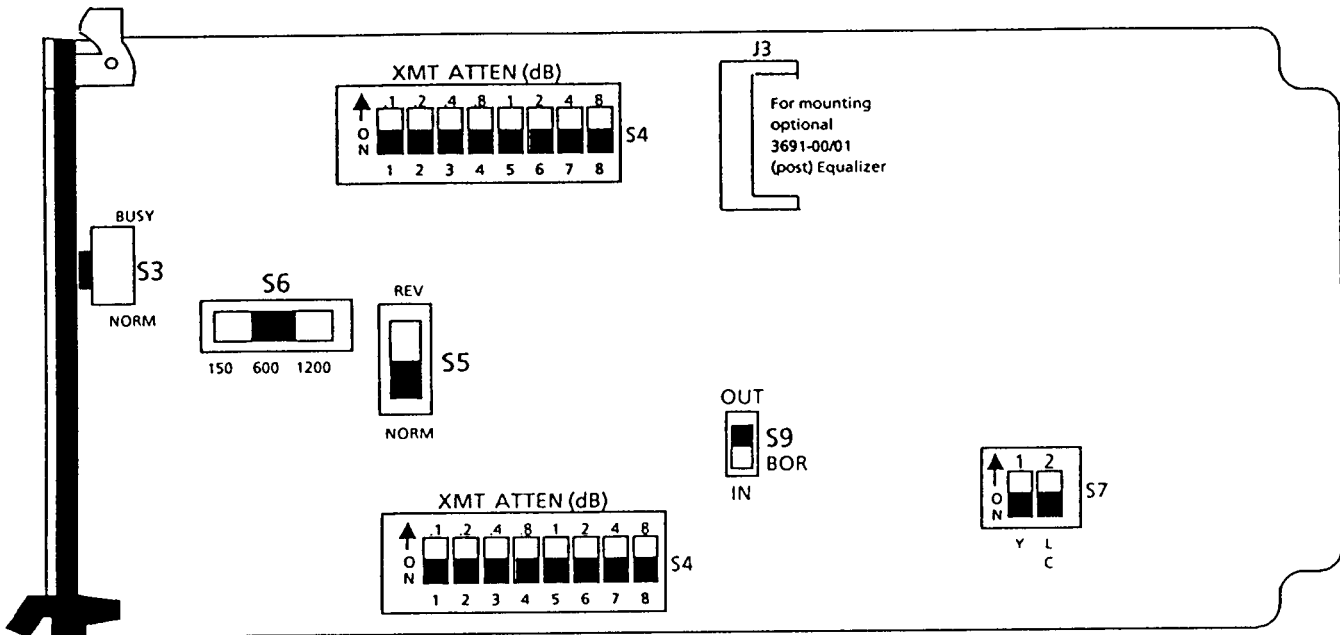

Figure 8. 3658-07 (Issue 6) Option Locations

Table 2. 3658-07 (Issue 6) Option Summary

Option	Position	Function/Remarks
J3	See Section 369-100-201	Jack for mounting an optional transmit post-equalizer (3691-00/01)
S3	NORM	For in-service operation
	BUSY	For testing or alignment
S4	See Paragraph 8.1	Provides up to 16.5dB XMT ATTEN in 0.1dB increments
S5	NORM	For normal operation
	REV/NORM (as required)	For tandem operation, on 4-wire metallic facility, with an FXS; Place in REV position if the 4W FXS's simplex leads are normal; place in the NORM position if the 4W FXS's simplex leads are reversed
S6	150/600/1200 (as required)	150 ohm 4-wire metallic facility matching impedance 600 ohm 4-wire metallic facility matching impedance 1200 ohm 4-wire metallic facility matching impedance
S7-1 (Y)	S7-1=ON S7-1=OFF	During carrier failure, leads 1 and 2 are under control of the TP RELAY; Provides switched ground output on lead 1 (pin 2). Provides isolated contact closure between leads 1 (pin 2) and 2 (pin 6)
S7-2 To S7-7	ON/OFF (As Required)	During carrier failure and 2.5 seconds after immediate alarm: LC RELAY closes;
S8	See Paragraph 8.2	Provides up to 16.5dB RCV ATTEN in 0.1dB increments
S9	BOR=OUT BOR=IN	Build-Out-Resistor: To remove 400 ohms on-board for loops greater than 1.1k ohms. To include 400 ohms resistance for shorter loops.

8. ALIGNMENT

8.1 Transmit Alignment

The XMT ATTEN switch S4 is a prescription control that provides 0.0 to 16.5dB gain in 0.1dB increments to accommodate an input TLP range from – 16.0 to + 0.5dBm. To adjust the transmit path to the proper operating level, the difference between – 16.0 and the transmit TLP at T&R must be obtained.

EXAMPLE: For a transmit TLP of – 2.0dBm;
 $-2 - (-16.0) = 14.0$

Set switches S4–6 (2), S4–7 (4), and S4–8 (8) to the ON (IN) position.

8.2 Receive Alignment

The RCV ATTEN switch S8 is a prescription control that provides 0.0 to 16.5dB gain in 0.1dB increments to accommodate an input TLP range from +7.0 to–9.5dBm. To adjust the receive path to the proper operating level, the difference between +7.0 and the receive TLP at T1 & R1 must be obtained.

EXAMPLE: For a receive TLP of – 6.0dBm;
 $7.0 - (-6.0) = 13.0$

Set switches S4–5 (1), S4–7 (4), and S4–8 (8) to the ON (IN) position.

9. TECHNICAL ASSISTANCE

If technical assistance is required, contact Charles Industries' Technical Services Center at:

847–806–8500
 847–806–8556 (FAX)
 800–607–8500
 techserv@charlesindustries.com (e-mail)

10. WARRANTY & CUSTOMER SERVICE

10.1 Warranty

Charles Industries, Ltd. offers an industry-leading, 5-year warranty on products manufactured by Charles Industries. Contact your local Sales Representative at the address or telephone numbers below for warranty details. The warranty provisions are subject to change without notice. The terms and conditions applicable to any specific sale of product shall be defined in the resulting sales contract.

Charles Industries, Ltd.
 5600 Apollo Drive
 Rolling Meadows, Illinois 60008–4049
 847–806–6300 (Main Office)
 847–806–6231 (FAX)

10.2 Field Repairs (In-Warranty Units)

Field repairs involving the replacement of components within a unit are not recommended and may void the warranty and compatibility with any applicable regulatory or agency requirements. If a unit needs repair, contact Charles Industries, Ltd. for replacement or repair instructions, or follow the *Repair Service Procedure* below.

10.3 Advanced Replacement Service (In-Warranty Units)

Charles Industries, Ltd. offers an “advanced replacement” service if a replacement unit is required as soon as possible. With this service, the unit will be shipped in the fastest manner consistent with the urgency of the situation. In most cases, there are no charges for in-warranty repairs, except for the transportation charges of the unit and for a testing and handling charge for units returned with no trouble found. Upon receipt of the advanced replacement unit, return the out-of-service unit in the carton in which the replacement was shipped, using the pre-addressed shipping label provided. Call your customer service representative at the telephone number above for more details.

10.4 Standard Repair and Replacement Service (Both In-Warranty and Out-Of-Warranty Units)

Charles Industries, Ltd. offers a standard repair or exchange service for units either in- or out-of-warranty. With this service, units may be shipped to Charles Industries for either repair and quality testing or exchanged for a replacement unit, as determined by Charles Industries. Follow the *Repair Service Procedure* below to return units and to secure a repair or replacement. A handling charge applies for equipment returned with no trouble found. To obtain more details of this service and a schedule of prices, contact the CI Service Center at 217–932–5288 (FAX 217–932–2943).

Repair Service Procedure

1. Prepare, complete, and enclose a purchase order in the box with the equipment to be returned.
2. Include the following information:
 - Company name and address
 - Contact name and phone number
 - Inventory of equipment being shipped
 - Particulars as to the nature of the failure
 - Return shipping address
3. Ship the equipment, purchase order, and above-listed information, transportation prepaid, to the service center address shown below.

CI Service Center
503 N.E. 15th St., P.O. Box 339
Casey, IL 62420–2054
4. Most repaired or replaced units will be returned within 30 or 45 days, depending on the product type and availability of repair parts. Repaired units are warranted for either 90 days from the date of repair or for the remaining unexpired portion of the original warranty, whichever is longer.

11. SPECIFICATIONS

11.1 Electrical

The electrical characteristics of the 3658–03 and 3658–07 (Issue 6) are as follows:

11.1.1. **Current Requirements At – 48Vdc:**

- (a) Idle, 26mA; Busy, 48mA.

11.1.2. **VF Transmission Specifications (Single - Ended)**

- (a) PERMISSIBLE MODES: 4L–4T, 4N–4T, 4T–4L, 4T–4N, and 4T–4T
- (b) 4-WIRE IMPEDANCE: 150, 600, 1200 ohms, selectable.
- (c) LINE SIDE LEVELS: Transmit (fixed) and receive (fixed), +5.2dBm TLP.
- (d) XMT INPUT (T&R) TLP RANGE: – 16.0 to + 0.5dBm (adjustable from 0 to 16.5dB in 0.1dB increments via the XMT ATTEN switches).
- (e) EQUALIZATION (OPTIONAL 3691–00/01): Provides post equalization for all gauges of non-loaded or H88 loaded cable with up to 15dB of 1kHz insertion loss.
- (f) RCV OUTPUT (T1&R1) TLP RANGE: –9.5 to + 7.0dBm (adjustable from 0 to 16.5dB in 0.1dB increments via the RCV ATTEN switches).
- (g) 1000Hz GAIN: Transmit (fixed), +21.2dB; receive (fixed), + 1.8dB.
- (h) TRANSMIT AND RECEIVE PATH FREQUENCY RESPONSE (Referenced at 1kHz):

Freq. (Hz)	XMT (dB)	RCV (dB)
60	–14 maximum	—
200	0.15 to –2.0	0.0 to –1.0
300	+0.15 to –1.5	+0.15 to –1.5
1000	0.0 (REF)	0.0 (REF)
3000	+0.15 to –1.5	+0.15 to –1.5
3400	0.0 to –1.5	0.0 to –1.5
4000	–14 maximum	–14 maximum
4600	–32 maximum	–28 maximum

- (i) LONGITUDINAL BALANCE (Referenced to – 16 TLP): 74dB minimum at 200Hz to 1kHz; 69dB minimum at 3kHz.
- (j) SIGNAL TO DISTORTION RATIO: 35dB minimum at 0.0 to – 30dBm0; 29dB minimum at –40dBm0; 25dB minimum at – 45dBm0.
- (k) RETURN LOSS: Echo, 23dB minimum at 300Hz and 3kHz; 28dB minimum at 1kHz.
- (l) TRANSMIT/RECEIVE IDLE CHANNEL NOISE: 20dBmC0 maximum.
- (m) CROSSTALK: 61dBm0 minimum at 400Hz, 71dBm0 minimum at 700Hz to 1kHz, 70dBm0 minimum at 3kHz.
- (n) LEVEL TRACKING: ± 0.25 dB from + 3.0 to –37dBm0; ± 0.5 dB from –38 to – 50dBm0.

11.1.3. Signaling

- (a) RING LEAD RESISTANCE TO GROUND: 410 ohms nominal.
- (b) TIP GROUND DETECTOR SENSITIVITY: 850 ohms must be detected; 10k ohms must not be detected.
- (c) RINGING SENSITIVITY: 65Vrms at 20Hz.

11.2 Physical

See Table 3 for the physical characteristics of the unit.

Table 3. Physical Specifications

Feature	U.S.	Metric
Height	4.3 inches	10.9 centimeters
Width	1.36 inches	3.5 centimeters
Depth	10.4 inches	26.4 centimeters
Weight	16 ounces	454 grams
Temperature	32° to 122°F	0° to 50°C

