

# 3653-05 4-Wire Transmission Only with Sealing Current (4W TO W/SC) Channel Unit

Complies with UL Standard 1459 Second Edition\*

CONTENTS	PAGE
Part 1. GENERAL .....	2
Part 2. INSPECTION .....	2
Part 3. APPLICATION GUIDELINES .....	3
Part 4. CIRCUIT DESCRIPTION .....	3
Part 5. MOUNTING .....	5
Part 6. INSTALLER CONNECTIONS .....	5
Part 7. OPTIONS .....	6
Part 8. ALIGNMENT .....	7
Part 9. TESTING .....	7
Part 10. TECHNICAL ASSISTANCE .....	8
Part 11. WARRANTY & CUSTOMER SERVICE .....	8
Part 12. SPECIFICATIONS .....	9

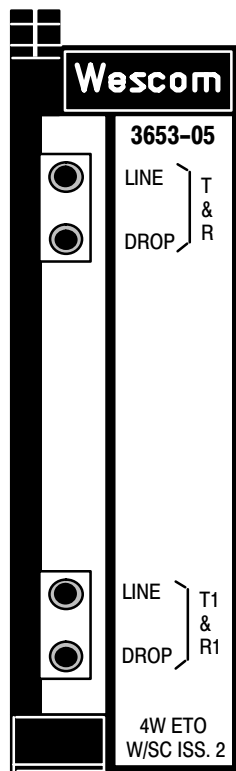

Figure 1. 3653-05 4W TO W/SC Channel Unit

## 1. GENERAL

### 1.1 Document Purpose

This document provides general, installation and optioning information for the Charles Industries 360/363 D4 Digital Carrier Terminal, shown in Figure 1.

### 1.2 Equipment Function

The Charles Industries 3653–05 4W TO (Issue 2) is a channel unit designed for operation in a Charles Industries 360/363 D4 Digital Carrier Terminal to provide an interface to a 4-wire voice frequency extension on private lines with no DC signaling.

#### **CAUTION**

<b>Field repairs/modifications may void compliance with UL 1459 – Second Edition.</b>
---

### 1.3 Equipment Location/Mounting

Occupies one channel slot of a Charles Industries 360/363 D4 Digital Carrier terminal.

### 1.4 Equipment Features

The 3653–05 include the following features:

- Compliance with AT&T Publication 43801 specifications
- Compliance with UL 1459 – Second Edition
- Prescription attenuation adjustments for the transmit and receive levels
- Switch-selectable terminating impedances of 150/600/1200-ohms at the 4-wire interface ports
- Front-panel bantam breaking-jacks for accessing the transmit and receive ports
- Sealing current configurations, with automatic ZAP, are switch optional

## 2. INSPECTION

### 2.1 Inspect for Damages

Inspect the equipment thoroughly upon delivery. If the equipment has been damaged in transit, immediately report the extent of damage to the transportation company.

### 2.2 Equipment Identification

Charles Industries' equipment is identified by a model and issue number imprinted on the front panel or located elsewhere on the equipment. Each time a major engineering design change is made on the equipment, the issue number is advanced by 1 and imprinted on subsequent units manufactured. Therefore, be sure to include both the model number and its issue number when making inquiries about the equipment.

### 2.3 Static Concerns

Each module is shipped in static-protective packaging to prevent electrostatic charges from damaging static-sensitive devices. Use approved static-preventive measures, such as static-conductive wrist straps and a static-dissipative mat, when handling modules outside of their protective packaging. A module intended for future use should be tested as soon as possible and returned to its original protective packaging for storage.



STATIC-SENSITIVE

This equipment contains static-sensitive electronic devices. To prevent electrostatic charges from damaging static-sensitive units:

- Use approved static preventive measures (such as a static-conductive wrist strap and a static-dissipative mat) at all times whenever touching units outside of their original, shipped static-protective packaging.
- Do not ship or store units near strong electrostatic, electromagnetic, or magnetic fields.
- Use static-protective packaging for shipping or storage.

### 3. APPLICATION GUIDELINES

The Charles Industries 3653–05 Channel Units provide switch selectable 150, 600, and 1200 ohms impedance options. It also provides switch-selectable sealing current configuration options.

Typical applications for these channel units are for private line data services requiring a metallic facility extension, tandeming of circuits employing in-band signaling (SF circuits), and other applications where voice transmission, without signaling, is required.

Typical applications diagrams are shown in Figure 2 and Figure 3.

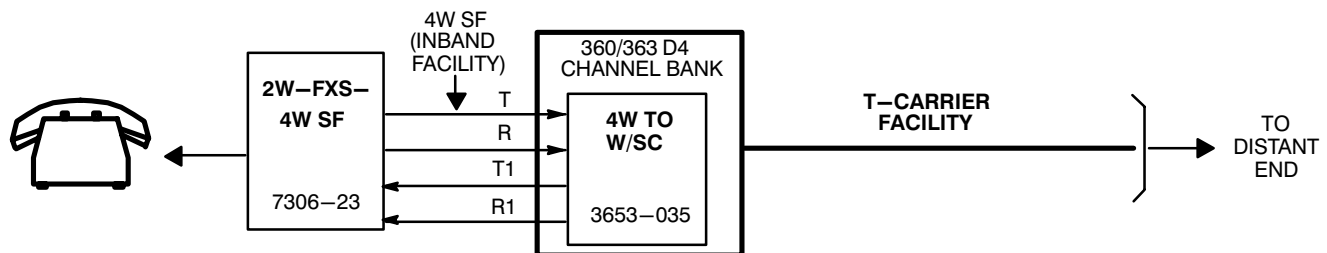

Figure 2. 3653–05 Tandem Application

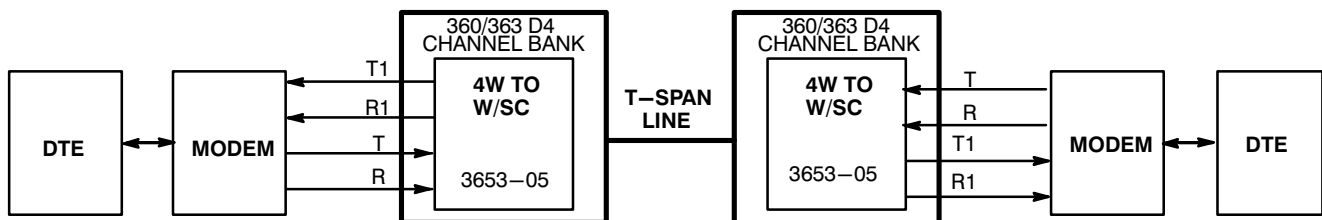

Figure 3. 3653–05 Data Application

### 4. CIRCUIT DESCRIPTION

Refer to the 3653–05 (Issue 2) block diagram, Figure 4, as needed while reading the following circuit description.

#### 4.1 Transmit VF Path

VF (voice frequency) signals applied to the input T (pin 50) and R (pin 48) are routed through the front-panel DROP and LINE lifting jacks and the impedance selector switch S1. Switch S1 selects a terminating impedance of 150, 600, or 1200 ohms to match the impedance of the facility and provide a balanced input to transformer T1. Transformer T1 provides dc isolation from the line.

The output level of Transformer T1 is adjusted via the XMT ATTEN circuit (prescription attenuation) which provides 0 to 24.5dB of attenuation in 0.1dB increments. The XMT ATTEN circuit adjust the digital milliwatt standard at the XDATA lead (pin 44). The input T and R leads will accept a TLP range from –16 to +8.5dBm.

The adjusted VF signal is then applied to the XMT FILTER for suppression of frequencies that are outside of the bandwidth of the standard voice frequency and prevents them from entering the ENCODER.

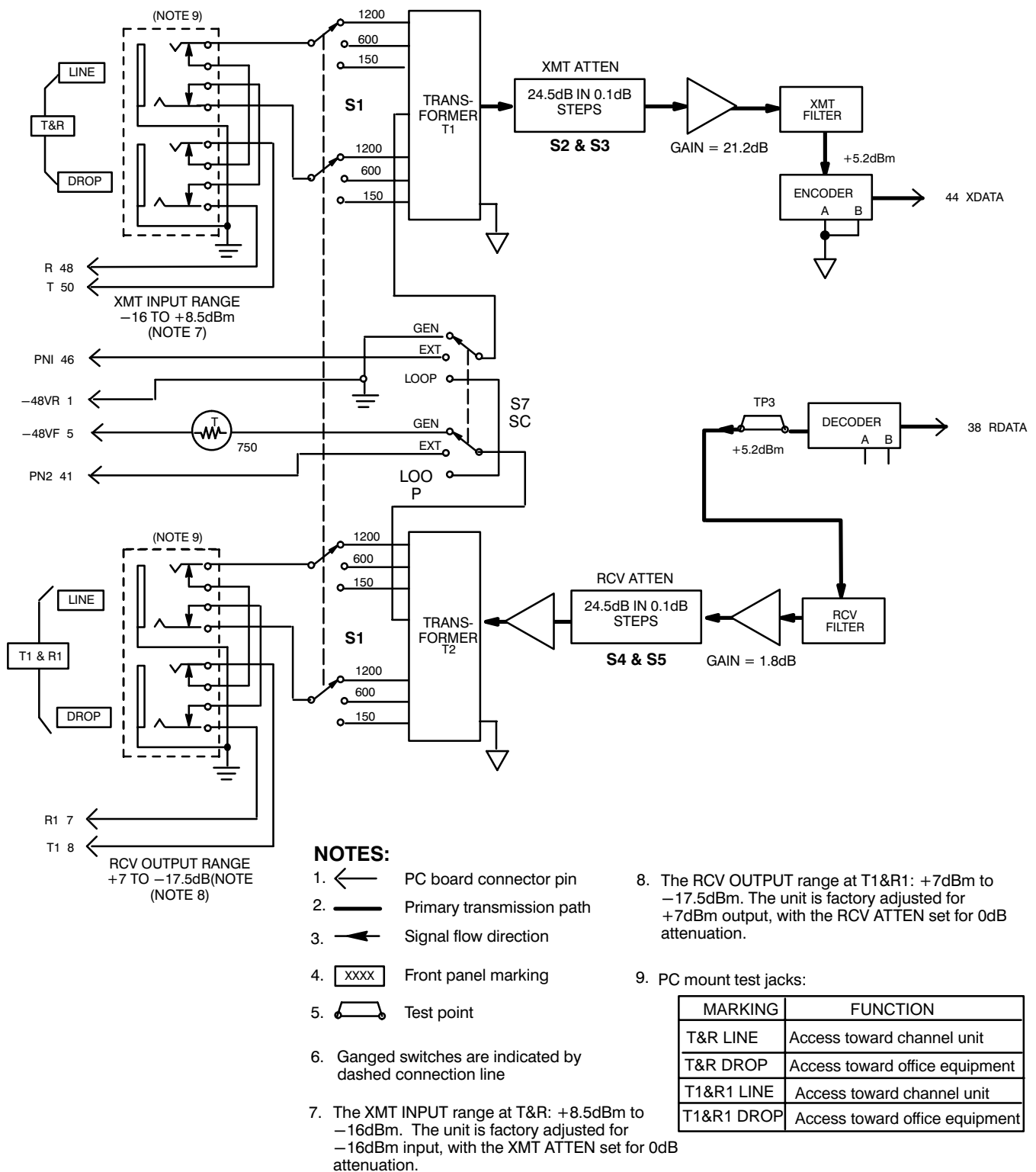

Figure 4. 3653-05 (Issue 2) 4W ETO W/SC Channel Unit Block Diagram

The filtered VF signal is then applied to the ENCODER, through a dc blocking capacitor. The ENCODER performs an analog-to-digital (A/D) conversion of the VF signal and sends the resulting PCM (pulse code modulation) signal to the 360/363 D4 terminal common equipment via the XDATA lead.

## 4.2 Receive Path

The PCM digital signal transmitted from the far end is received by the 360/363 D4 terminal common equipment, and in turn, is routed to the 3653–05 via the RDATA lead. The DECODER receives this signal and performs a digital-to-analog (D/A) conversion of the signal.

The output of the DECODER is fed to the RCV FILTER, which suppresses frequencies that are outside of the standard voice frequency bandwidth (0 to 4kHz). The filtered analog output of the RCV FILTER is applied to the RCV ATTEN circuit and the fixed RCV path GAIN circuits which, acting together, set the receive gain to the exact level required to interface with a range of office TLPs. The RCV ATTEN circuit provides finely controlled adjustment of the output level from +7dBm to –17.5dBm.

The output from the RCV ATTEN circuit is applied through a push-pull arrangement, including frequency compensation for the transformer, to TRANSFORMER T2. Transformer T2 provides dc isolation and balance to the line. The output of the transformer is fed through switch S1, which selects the required impedance (150, 600, or 1200-ohms) to match the impedance of the facility.

## 4.3 Sealing Current

The optionable SC (sealing current) switch S7 is a 3-position slide switch. Its positions are labeled GEN, EXT and LOOP.

The GEN position supplies ground to T/R, and –48Vdc to T1/R1, through a 750-ohm thermistor. When the card is first plugged in, the current surges to approximately 100mA, short loop, for less than 10 seconds. This higher sealing current breaks down the high resistance film which might build up at unsoldered, hand-twisted splices. The current will decrease to approximately 20mA after 30 seconds, to maintain the normal loop resistance.

The EXT position permits the customer to supply sealing current from an external source via pin 46 to the center tap of TRANSFORMER T1, and pin 41 to the center tap of TRANSFORMER T2.

The LOOP position simply connects the center taps of T1 and T2 together and is used when the other end of the loop is the sealing current source.

## 5. MOUNTING

The 3653–05 mount in one channel-unit slot of a 360/363 D4 terminal. The 3653–05 is equipped with an insert/eject lever mechanism. The front panel of the unit is hinged and constitutes the lever of the insert/eject mechanism. The mechanism ensures a positive connection between the channel unit's card-edge connector and the backplane connector when the unit is installed. This mechanism also facilitates removal of the unit.

To install a channel unit into a terminal, first lift the bottom edge of the front panel until it is parallel with the top edge of the card. Insert the unit into the appropriate card guide slots, and slide it in until the top part of the front panel is under the front lip of the terminal. Then push down on the front panel until it is in the vertical position. Press in the bottom edge of the front panel until it snaps and locks into place.

### CAUTION

**Removal and installation of channel units should be done with care. Do not force a unit into place. If excessive resistance is encountered while installing a unit, remove it and check the card guides and connector to verify proper alignment and the absence of foreign material.**

## 6. INSTALLER CONNECTIONS

Installer connections are made to the channel unit by wire-wrapping leads onto the associated 50-pin connectors located on the backplane assembly of the 360/363 D4 terminal. When installing a 3653–05 into a non-connectORIZED 360/363 D4 terminal (00-suffixed), make the required connections to the T&R (pins 50 and 48), T1&R1 (pins 8 and 7), and the conditioning leads 1 and 2 (pins 2 and 6) on the appropriate connector. On connectorized 360/363 terminals (360–10, –11, etc.), connections are made via 25-pair female connectors (CINCH 222–22–50–023 or equivalent) to the appropriate 25-pair male connectors of the 360/363 D4 terminal. Refer to Section 360–000–200 for the wiring diagrams of the female connectors with respect to the terminal being utilized. Electrical connections are made when the unit is installed.

## 7. OPTIONS

The 3653–05 is equipped with DIP switches and slide switches that are used to condition the module for proper application and operation. Refer to Figure 5 and Table 1 for option locations and option conditioning requirements.

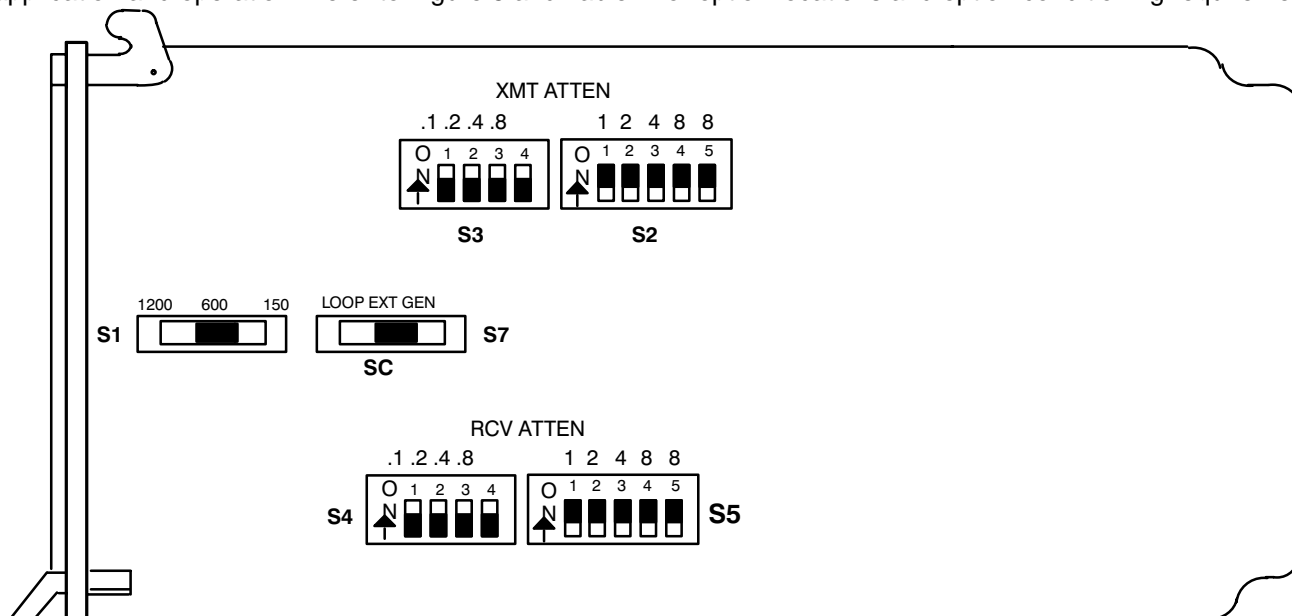

Figure 5. 3653–05 4W TO W/SC Option Locations and Optioning Summary

Table 1. Description of Figure 5

Option	Position	Function
S1	As required	3-position slide switch selects a transmit and receive path impedance of 150, 600, or 1200 ohms to match the impedance of the facility.
S2	See para. 8.1	5-section DIP switch selects transmit prescription attenuation between 0dB and 23dB in 1dB steps. Use in conjunction with S3 to achieve required attenuation.
S3	See para. 8.1	4-section DIP switch selects transmit prescription attenuation between 0dB and 1.5dB in 0.1dB steps. Use in conjunction with S2 to achieve required attenuation.
S4	See para. 8.2	4-section DIP switch selects receive prescription attenuation between 0dB and 1.5dB in 0.1dB steps. Use in conjunction with S5 to achieve required attenuation.
S5	See para. 8.2	5-section DIP switch selects receive prescription attenuation between 0dB and 23dB in 1dB steps. Use in conjunction with S4 to achieve required attenuation.
S6	N/A	Designation S6 is not used on this module
S7	GEN	3-position slide switch selects mode of sealing current supply; sealing current generated from system with automatic ZAP when unit first plugged in.
	EXT	Sealing current supplied from an external source via pins 46 and 41.
	LOOP	Sealing current supplied from far end of loop.

### 7.1 Switch S1 (Impedance Selector)

Switch S1 is a 3-position slide switch that selects a transmit and receive path impedance of 150, 600, or 1200 ohms to match the impedance of the facility.

## 7.2 Switch S2 (XMT Prescription Attenuation)

Switch S2 is a 5-section DIP switch that selects attenuation between 0dB and 23dB in 1dB increments. This switch, in conjunction with switch S3, sets the XMT LEVEL to the digital milliwatt standard, with an input range of -16 to +8.5dBm at T/R (pins 50 and 48).

## 7.3 Switch S3 (XMT Prescription Attenuation)

Switch S3 is a 4-section DIP switch that selects attenuation between 0dB and 1.5dB in 0.1dB increments. This switch is used in conjunction with S2.

## 7.4 Switch S4 (RCV Prescription Attenuation)

Switch S4 is a 4-section DIP switch that selects attenuation between 0dB and 1.5dB in 0.1dB increments. This switch is used in conjunction with S5.

## 7.5 Switch S5 (RCV Prescription Attenuation)

Switch S5 is a 5-section DIP switch that selects attenuation between 0dB and 23dB in 1dB increments. This switch, in conjunction with switch S4, sets the RCV LEVEL to the digital milliwatt standard, with an output range of -17.5 to +7.0dBm.

## 7.6 Switch S7 (Sealing-Current Selector)

Switch S7 is a 3-position slide switch that selects the mode of sealing current supply. Placing this switch in the GEN position selects sealing current generated from the system and also provides automatic ZAP when the card is first plugged in. The current surges to about 100mA for less than 10 seconds and then decreases to approximately 20mA after 30 seconds. Placing this switch in the EXT position allows the customer to supply sealing current from an external source via pins 46 and 41. In the LOOP position, the center taps of transformers T1 and T2 are tied together so that sealing current can be supplied from the far end of the loop.

# 8. ALIGNMENT

The input and output levels of the 3653–05 channel units are adjusted by placing the individual switches of DIP switches S2, S3, S4, and S5 to the positions required to achieve proper operation. These channel units are preset at the factory such that with an input of 1.0kHz at -16dBm  $\pm$ 0.1dBm applied to T & R (pins 50 and 48) and 0dB XMT ATTN, the encoder output (XDATA, pin 44) will be equivalent to the standard digital milliwatt signal. The receive side is preset such that with the standard digital milliwatt signal input at RDATA (pin 38) and 0dB RCV ATTN, the output at T1 and R1 (pins 8 and 7) will be +7.0dBm  $\pm$ 0.1dBm.

## 8.1 Transmit Alignment

The XMT ATTN switches S2 and S3 are prescription controls that provide attenuation from zero to 24.5dB in increments of 0.1dB to accommodate an input TLP range from -16.0 to +8.5dB. To adjust the transmit path to the proper operation level, the difference between -16 and the transmit TLP at T&R must be obtained:

$$[\text{XMT ATTN} = \text{TLP} - (-16)]$$

For an input TLP of -2dBm, the XMT ATTN = -2 - (-16) = 14dB. Set the sum of the switches on S2 & S3 to 14.

## 8.2 Receive Alignment

The RCV ATTN switches S4 and S5 are prescription controls that provide attenuation from zero to 24.5dB in increments of 0.1dB to accommodate an output TLP range from +7.0 to -17.5dB. To adjust the receive path to the proper operation level, the difference between +7 and the receive TLP at T1&R1 must be obtained:

$$[\text{RCV ATTN} = 7 - \text{TLP}]$$

For an output TLP of -6dBm, the RCV ATTN = 7 - (-6) = 13dB. Set the sum of the switches on S4 & S5 to 13.

# 9. TESTING

After completing Parts 4 through 8, place a call end-to-end through the facility to verify proper operation. If trouble is encountered, recheck all installer connections, optioning, alignment settings, and verify that the channel unit is making positive contact with the backplane connector. If the difficulty persists, replace the unit with one known to be good and retest. Section 360–001–205 provides information about channel unit testing for fault diagnosis or verification of circuit operation.

## 10. TECHNICAL ASSISTANCE

If technical assistance is required, contact Charles Industries' Technical Services Center at:

847–806–8500  
847–806–8556 (FAX)  
800–607–8500  
techserv@charlesindustries.com (e-mail)

## 11. WARRANTY & CUSTOMER SERVICE

### 11.1 Warranty

Charles Industries, Ltd. offers an industry-leading, 5-year warranty on products manufactured by Charles Industries. Contact your local Sales Representative at the address or telephone numbers below for warranty details. The warranty provisions are subject to change without notice. The terms and conditions applicable to any specific sale of product shall be defined in the resulting sales contract.

Charles Industries, Ltd.  
5600 Apollo Drive  
Rolling Meadows, Illinois 60008–4049  
847–806–6300 (Main Office)  
847–806–6231 (FAX)

### 11.2 Field Repairs (In-Warranty Units)

Field repairs involving the replacement of components within a unit are not recommended and may void the warranty and compatibility with any applicable regulatory or agency requirements. If a unit needs repair, contact Charles Industries, Ltd. for replacement or repair instructions, or follow the *Repair Service Procedure* below.

### 11.3 Advanced Replacement Service (In-Warranty Units)

Charles Industries, Ltd. offers an “advanced replacement” service if a replacement unit is required as soon as possible. With this service, the unit will be shipped in the fastest manner consistent with the urgency of the situation. In most cases, there are no charges for in-warranty repairs, except for the transportation charges of the unit and for a testing and handling charge for units returned with no trouble found. Upon receipt of the advanced replacement unit, return the out-of-service unit in the carton in which the replacement was shipped, using the pre-addressed shipping label provided. Call your customer service representative at the telephone number above for more details.

### 11.4 Standard Repair and Replacement Service (Both In-Warranty and Out-Of-Warranty Units)

Charles Industries, Ltd. offers a standard repair or exchange service for units either in- or out-of-warranty. With this service, units may be shipped to Charles Industries for either repair and quality testing or exchanged for a replacement unit, as determined by Charles Industries. Follow the *Repair Service Procedure* below to return units and to secure a repair or replacement. A handling charge applies for equipment returned with no trouble found. To obtain more details of this service and a schedule of prices, contact the CI Service Center at 217–932–5288 (FAX 217–932–2943).

#### *Repair Service Procedure*

1. Prepare, complete, and enclose a purchase order in the box with the equipment to be returned.
2. Include the following information:
  - Company name and address
  - Contact name and phone number
  - Inventory of equipment being shipped
  - Particulars as to the nature of the failure
  - Return shipping address



3. Ship the equipment, purchase order, and above-listed information, transportation prepaid, to the service center address shown below.

CI Service Center  
 503 N.E. 15th St., P.O. Box 339  
 Casey, IL 62420–2054

4. Most repaired or replaced units will be returned within 30 or 45 days, depending on the product type and availability of repair parts. Repaired units are warranted for either 90 days from the date of repair or for the remaining unexpired portion of the original warranty, whichever is longer.

## 12. SPECIFICATIONS

### 12.1 Electrical Specifications

The electrical characteristics of the 3653–05 (Issue 2) are as follows:

#### 12.1.1. Transmission Specifications (Single Ended)

- (a) 4-WIRE IMPEDANCE: 150/600/1200 ohms.
- (b) LINE-SIDE TRANSMIT AND RECEIVE LEVELS: +5.2dBm TLP (fixed).
- (c) DROP-SIDE LEVELS: Transmit Input, –16.0dBm (minimum), +8.5dBm (maximum); Receive Output, –17.5dBm (minimum), +7.0dBm (maximum).
- (d) 1000Hz GAIN: Transmit (fixed), +21.2dB; Receive (fixed), +1.8dB
- (e) TRANSMIT AND RECEIVE ATTENUATION: 0.0 to 24.4dB in 0.1dB increments.
- (f) TRANSMIT AND RECEIVE PATH FREQUENCY RESPONSE (Referenced at 1kHz):

FREQUENCY (Hz)	XMT (dB)	RCV (dB)
60	–14 maximum	—
200	0.15 to –2.0	0 to –1.0
300	0.15 to –0.15	0.15 to –0.15
1000	0 (Reference)	0 (Reference)
3000	0.15 to –0.15	0.15 to –0.15
3400	0 to –1.5	0 to –1.5
4000	–14 maximum	–14 maximum
4600	–32 maximum	–28 maximum

- (g) LONGITUDINAL BALANCE: 74dB minimum at 200Hz to 1kHz; 69dB minimum at 3kHz (Referenced to –16dBm TLP).
- (h) SIGNAL TO DISTORTION RATIO: 35dB minimum at 0 to –30dBm<sub>0</sub>; 29dB minimum at –40dBm<sub>0</sub>; 25dB minimum at –45dBm<sub>0</sub>.
- (i) RETURN LOSS: 23dB minimum at 300Hz and 3kHz; 28dB minimum at 1kHz.
- (j) TRANSMIT/RECEIVE IDLE CHANNEL NOISE: 20dBm<sub>0</sub> maximum.
- (k) CROSSTALK: –61dBm<sub>0</sub> maximum at 400Hz; –71dBm<sub>0</sub> maximum at 700Hz to 1kHz; –70dBm<sub>0</sub> maximum at 3kHz.
- (l) LEVEL TRACKING (measured single-ended at 1010Hz): ±0.25dB from +3 to –37dBm<sub>0</sub>; ±0.5dB from –37 to –50dBm<sub>0</sub>.
- (m) TYPICAL CURRENT DRAIN: 15mA at –48Vdc (sealing current external).

**12.2 Physical Specifications**

See Table 2 for the physical characteristics of the unit.

**Table 2. Physical Specifications**

<b>Feature</b>	<b>U.S.</b>	<b>Metric</b>
Height	4.27 inches	10.8 centimeters
Width	1.39 inches	3.5 centimeters
Depth	10.3 inches	26.1 centimeters
Weight	12 ounces	340 grams
Temperature	32 to 122°F	0 to 50°C

