

3636-00 0-20kbps Asynchronous Data Channel Unit

CONTENTS	PAGE
Part 1. GENERAL	2
Part 2. INSPECTION	2
Part 3. FUNCTIONAL DESCRIPTION	3
Part 4. MOUNTING	4
Part 5. INSTALLER CONNECTIONS	4
Part 6. OPTIONS	5
Part 7. TECHNICAL ASSISTANCE	5
Part 8. WARRANTY & CUSTOMER SERVICE	5
Part 9. SPECIFICATIONS	6

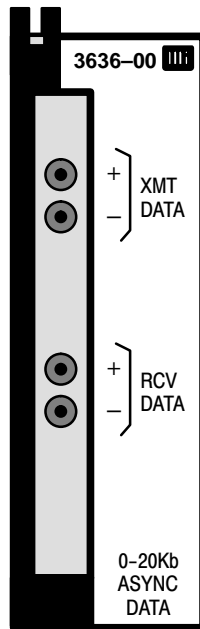

Figure 1. 3636-00 Asynchronous Data Channel Unit

1. GENERAL

1.1 Document Purpose

This document provides information for the Charles Industries 3636–00 0–20kbps Asynchronous Data Channel Unit used in the Charles Industries 360/363 D4 Digital Carrier Terminal Channel Bank. The 3636-00 is shown in Figure 1.

1.2 Document Status

This document is reprinted to include a general editorial update.

1.3 Equipment Function

The 3636-00 provides for transmission of asynchronous 0–20kbps data over T1 or T1C lines via the 360/363 D4 Digital Carrier Terminal Channel Bank. The data is coded for insertion into the T1/T1C bit stream by a 2-bit transitional coding process which codes only the data transitions (mark-to-space and space-to-mark) for transmissions. On the receive side, the incoming information from the T1/T1C bit stream is decoded to reproduce the data transitions. Transition distortion introduced by the 3636–00 is a maximum 10 percent at 20kbps; distortion is less at lower data rates.

The 3636-00 provides input (transmit) and output (receive) impedances of 135 ohms, and accepts CCITT V.35 data voltage levels. On the transmit side, the 3636–00 recognizes a mark (logic 1) as a minimum voltage of –200mV, and a space (logic 0) as a minimum voltage of +200mV. On the receive side, the 3636–00 outputs a mark as a minimum voltage of –0.55V, and a space as a minimum voltage of +0.55V. The 3636–00 does not provide a V.35 connector or any V.35 protocol leads.

The 3636-00 is equipped with front-panel-mounted pin-jack type test points. These test points provide a means of monitoring the transmit and receive data via the differential input of an oscilloscope. The XMT DATA + and – test points provide access to the XDT and XDR leads, respectively. The RCV DATA + and – test points provide access to the RDT and RDR leads, respectively.

1.4 Equipment Location/Mounting

The 3636-00 installs in any channel slot of a D4 Digital Carrier Terminal Channel Bank. It can be installed in a terminal with other data, voice, or program channel units. Up to 48 3636–00 channel units can be installed in a single D4 Digital Carrier Terminal Channel Bank.

2. INSPECTION

2.1 Inspect for Damages

Inspect the equipment thoroughly upon delivery. If the equipment has been damaged in transit, immediately report the extent of damage to the transportation company.

2.2 Equipment Identification

Charles Industries' equipment is identified by a model and issue number imprinted on the front panel or located elsewhere on the equipment. Each time a major engineering design change is made on the equipment, the issue number is advanced by 1 and imprinted on subsequent units manufactured. Therefore, be sure to include both the model number and its issue number when making inquiries about the equipment.

2.3 Static Concerns

Each module is shipped in static-protective packaging to prevent electrostatic charges from damaging static-sensitive devices. Use approved static-preventive measures, such as static-conductive wrist straps and a static-dissipative mat, when handling modules outside of their protective packaging. A module intended for future use should be tested as soon as possible and returned to its original protective packaging for storage.

CAUTION

Do not ship or store modules near strong electrostatic, electromagnetic or magnetic fields. Use the original static-protective packaging for shipping or storage.

3. FUNCTIONAL DESCRIPTION

Refer to Figure 2, the 3636–00 0–20kbps Asynchronous Data Channel Unit Block Diagram, while reading the following description.

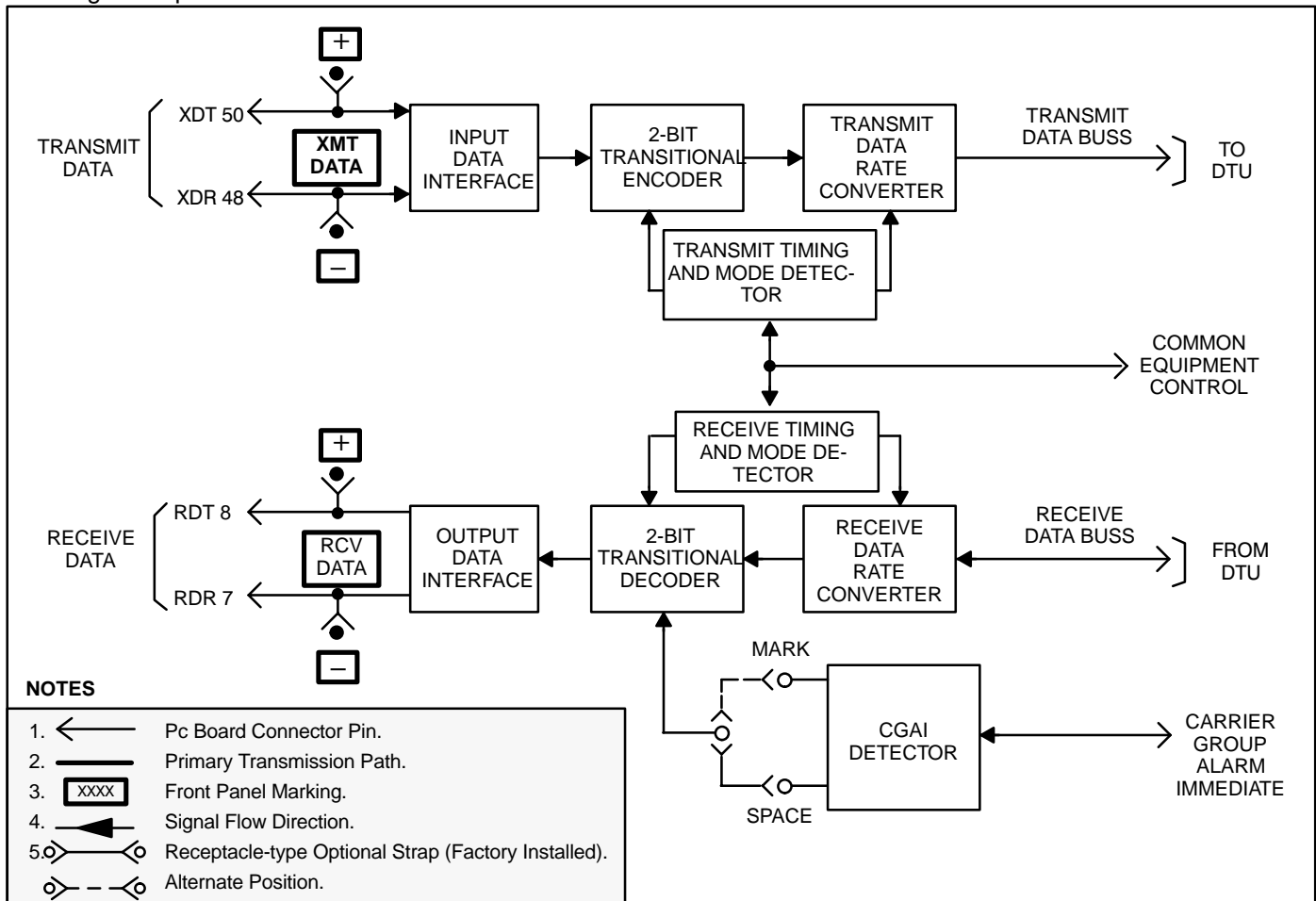

Figure 2. 3636-00 0–20kbps Asynchronous Data Channel Unit Functional Block Diagram

3.1 Transmit Side

Incoming data is applied to the 3636–00 on the XDT and XDR leads (pins 50 and 48, respectively). The INPUT DATA INTERFACE provides the 135 ohm input impedance, and converts the balanced incoming data to a digital logic signal. The digital signal is then routed to the 2-BIT TRANSITIONAL ENCODER.

The 2-BIT TRANSITIONAL ENCODER codes the data transitions into two bits: the transition bit indicates that a transition has taken place, the early/late bit indicates when the transition occurred in relationship to a 56kHz clock. The incoming data is sampled at a 56kHz rate by the 2-BIT TRANSITIONAL ENCODER. When a transition occurs, the 2-BIT TRANSITIONAL ENCODER outputs a transition bit which reflects the new data state (i.e., one or zero). Following the transition bit, the 2-BIT TRANSITIONAL ENCODER outputs the early/late bit which indicates at what point during the 56kHz sampling period the transition occurred. If the transition occurred during the first half of the sampling period, the early/late bit is one; if the transition occurred during the second half of the sampling period, the early/late bit is zero. All bits following the early/late bit reflect the data state until the next transition occurs and the coding process is repeated.

The coded data is clocked out of the 2-BIT TRANSITIONAL ENCODER at 56kHz and routed to the TRANSMIT DATA RATE CONVERTER. The TRANSMIT DATA RATE CONVERTER converts the data rate from 56kHz to 64kHz for integration into the T1/T1C bit stream. Data is clocked out of the TRANSMIT DATA RATE CONVERTER on the TRANSMIT DATA BUSS.

The TRANSMIT TIMING AND MODE DETECTOR circuit provides timing and control for the 2-BIT TRANSITIONAL ENCODER and the TRANSMIT DATA RATE CONVERTER. The clocks generated by the TRANSMIT TIMING

AND MODE DETECTOR are derived from the system clock coming in on the COMMON EQUIPMENT CONTROL leads. The MODE DETECTOR compensates for the difference between the system clock in Modes 1 and 3 (refer to Sections 360–000–100 and 360–001–205 for information regarding Modes 1 and 3).

3.2 Receive Side

On the receive side, the 3636–00 receives data at 64kHz on the RECEIVE DATA BUSS. This data is applied to the RECEIVE DATA RATE CONVERTER where it is stored, and then clocked out at 56kHz to the 2-BIT TRANSITIONAL DECODER. The 2-BIT TRANSITIONAL DECODER uses the incoming transition bits and early/late bits to reconstruct the output data. The decoded data is then routed to the OUTPUT DATA INTERFACE circuit which converts the digital logic levels to V.35 voltage levels and provides a 135 ohm output impedance. Control and timing for the RECEIVE DATA RATE CONVERTER and the 2-BIT TRANSITIONAL DECODER are provided by the RECEIVE TIMING AND MODE DETECTOR circuit.

3.3 Trunk Processing

During an alarm the 360/363 D4 Digital Carrier Terminal sends signals to the 3636–00 via the CARRIER GROUP ALARM IMMEDIATE (CGAI) lead. On the receive side, the 2-BIT TRANSITIONAL DECODER can be programmed to send either all marks or all spaces to the OUTPUT DATA INTERFACE during an alarm. This function is controlled by the CGAI DETECTOR and the MARK/SPACE option.

4. MOUNTING

The 3636-00 is designed to mount in one channel unit slot of a 360/363 D4 Digital Carrier Terminal Channel Bank. The 3636-00 is equipped with an insert/eject lever in the form of a top-hinged front panel. The insert/eject lever ensures positive connection of a channel unit’s card-edge connector to the backplane connector when the unit is installed and provides easy removal of the unit.

CAUTION

Installation and removal of modules should be done with care. Do not force a module into place. If excessive resistance is encountered while installing a module, remove the module and check the card guides and connector to verify proper alignment and the absence of foreign material.

5. INSTALLER CONNECTIONS

5.1 Connectorized 360/363 D4 Channel Banks

On connectorized 360/363 D4 Channel Banks (360–10, –11. etc.) connections are made via 25-pair female connectors (CINCH 222–22–50–023 or equivalent) to the appropriate 25-pair male connectors of the 360/363 D4 Channel Bank. Refer to Section 360–000–200 for the wiring diagrams of the female connectors with respect to the 360/363 D4 Channel Bank being used.

5.2 Non-Connectorized D4 Channel Banks

When installing a 3636–00 channel unit into a non-connectorized 360/363 D4 Channel Bank (00-suffixed), make the required connections as shown in Table 1.

Installer connections are made to the channel unit by wire-wrapping leads onto the associated 50-pin connectors on the backplane assembly of the 360/363 D4 Channel Bank.

Table 1. 3636-00 Installer Connections

Lead Designation	Pin	Equivalent Voice Channel Lead
XDT (Transmit Data Tip)	50	T
XDR (Transmit Data Ring)	48	R
RDT (Receive Data Tip)	8	T1
RDR (Receive Data Ring)	7	R1

Note: 360/363 D4 Channel Bank connectors J1A through J24A and J1B through J24B as equipped with 3636-00 modules.

6. OPTIONS

The 3636-00 is provided with a push-on jumper option. The location of this option is shown in Table 2.

The MARK/SPACE option selects a mark (negative voltage) or a space (positive voltage) to be continuously output on the RDT and RDR leads during trunk processing. To provide a mark, place the push-on jumper in the MARK position. To provide a space, place the push-on jumper in the SPACE position.

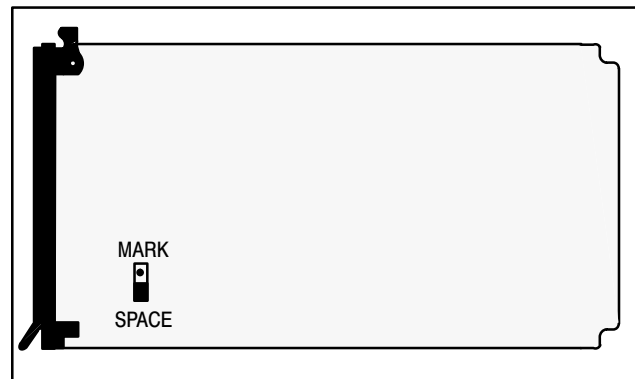

Figure 3. Locations of 3636-00 Options

Table 2. 3636-00 Option Summary

Option Position	Function
MARK	Outputs all marks (logic 1s) to leads RDT and RDR.
SPACE	Outputs all spaces (logic 0s) to leads RDT and RDR.

7. TECHNICAL ASSISTANCE

If technical assistance is required, contact Charles Industries' Technical Services Center at:

847–806–8500

847–806–8556 (FAX)

800–607–8500

techserv@charlesindustries.com (e-mail)

8. WARRANTY & CUSTOMER SERVICE

8.1 Warranty

Charles Industries, Ltd. offers an industry-leading, 5-year warranty on products manufactured by Charles Industries. Contact your local Sales Representative at the address or telephone numbers below for warranty details. The warranty provisions are subject to change without notice. The terms and conditions applicable to any specific sale of product shall be defined in the resulting sales contract.

Charles Industries, Ltd.

5600 Apollo Drive

Rolling Meadows, Illinois 60008–4049

847–806–6300 (Main Office)

847–806–6231 (FAX)

8.2 Field Repairs (In-Warranty Units)

Field repairs involving the replacement of components within a unit are not recommended and may void the warranty and compatibility with any applicable regulatory or agency requirements. If a unit needs repair, contact Charles Industries, Ltd. for replacement or repair instructions, or follow the *Repair Service Procedure* below.

8.3 Advanced Replacement Service (In-Warranty Units)

Charles Industries, Ltd. offers an “advanced replacement” service if a replacement unit is required as soon as possible. With this service, the unit will be shipped in the fastest manner consistent with the urgency of the situation. In most cases, there are no charges for in-warranty repairs, except for the transportation charges of the unit and for a testing and handling charge for units returned with no trouble found. Upon receipt of the advanced replacement unit, return the out-of-service unit in the carton in which the replacement was shipped, using the pre-addressed shipping label provided. Call your customer service representative at the telephone number above for more details.

8.4 Standard Repair and Replacement Service (Both In-Warranty and Out-Of-Warranty Units)

Charles Industries, Ltd. offers a standard repair or exchange service for units either in- or out-of-warranty. With this service, units may be shipped to Charles Industries for either repair and quality testing or exchanged for a replacement unit, as determined by Charles Industries. Follow the *Repair Service Procedure* below to return units and to secure a repair or replacement. A handling charge applies for equipment returned with no trouble found. To obtain more details of this service and a schedule of prices, contact the CI Service Center at 217–932–5288 (FAX 217–932–2943).

Repair Service Procedure

1. Prepare, complete, and enclose a purchase order in the box with the equipment to be returned.
2. Include the following information:
 - Company name and address
 - Contact name and phone number
 - Inventory of equipment being shipped
 - Particulars as to the nature of the failure
 - Return shipping address
3. Ship the equipment, purchase order, and above-listed information, transportation prepaid, to the service center address shown below.

CI Service Center
Route 40 East
Casey, IL 62420–2054
4. Most repaired or replaced units will be returned within 30 or 45 days, depending on the product type and availability of repair parts. Repaired units are warranted for either 90 days from the date of repair or for the remaining unexpired portion of the original warranty, whichever is longer.

9. SPECIFICATIONS

9.1 Electrical

The electrical characteristics of the 3636-00 are follows:

9.1.1. Output

- (a) IMPEDANCE: 135 ohms $\pm 10\%$ tip to ring; 150 ohms $\pm 10\%$ tip and ring to ground.
- (b) VOLTAGE LEVEL (135-OHM LOAD): Logic zero (space), +0.55V $\pm 20\%$; logic one (mark), –0.55V $\pm 20\%$.
- (c) TRANSITION TIME: <1% of nominal period.

- (d) OPEN CIRCUIT VOLTAGE: Tip to ring 1.50V maximum (allows for $\pm 10\%$ variation in output load).
- (e) SHORT CIRCUIT CURRENT: 0 ohm load tip to ring, 13.0mA maximum (allows for $\pm 10\%$ variation in output load).
- (f) TRANSITION DISTORTION: 10 percent, maximum at 20kbps

9.1.2. Input

- (a) IMPEDANCE: 135 ohms $\pm 10\%$ tip to ring; 150 ohms $\pm 10\%$ tip and ring to ground.
- (b) VOLTAGE LEVEL TIP TO RING: 1.65V maximum; minimum logic zero (space), +200mV; minimum logic one (mark), -200mV.
- (c) TRANSITION TIME: 33% of nominal period maximum

9.2 Physical

The physical characteristics of the 3636-00 are shown in Table 3:

Table 3. Physical Specifications

Feature	U.S.	Metric
Temperature	32 to 122°F	0 to 50°C
Weight	8 oz.	226g
Height	4.2 in.	10.6 cm
Width	1.35 in.	3.4 cm
Depth	10.3 in.	26.7 cm

