

# 3603-02 and 3603-32 Line Interface Units Mode 3 ESF (LIU-3E)

 Recognized under Underwriters Laboratories Standard 1459, Second Edition\*

CONTENTS	PAGE
Part 1. GENERAL .....	2
Part 2. INSPECTION .....	2
Part 3. APPLICATION GUIDELINES .....	3
Part 4. CIRCUIT DESCRIPTION .....	3
Part 5. OPTIONS .....	3
Part 6. MOUNTING .....	6
Part 7. TESTING .....	6
Part 8. TECHNICAL ASSISTANCE .....	7
Part 9. WARRANTY & CUSTOMER SERVICE .....	7
Part 10. SPECIFICATIONS .....	8

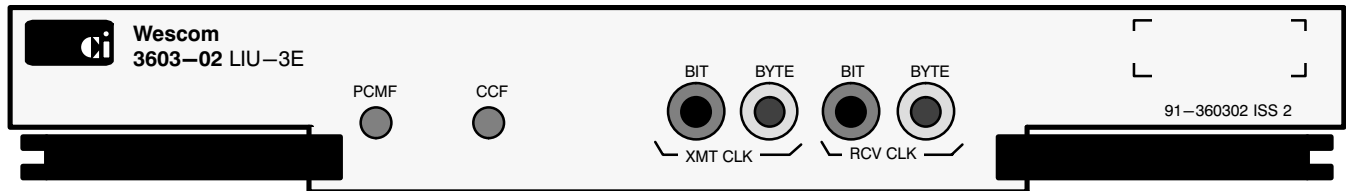

**Figure 1. 3603-02 LIU-3E Front Panel**

## 1. GENERAL

### 1.1 Document Purpose

This document provides general information about the Charles Industries 3603-02/32 Line Interface Units (LIU-3E), shown in Figure 1.

### 1.2 Document Status

This document is reprinted to include a general editorial update.

### 1.3 Equipment Function

The Charles Industries 3603-02/32 Line Interface Units (LIU-3E) are common equipment plug-in units for the Charles Industries 360 and 363 D4 Digital Carrier Terminals (also known as channel bank assemblies). The 3603-02 (Equipment Issue 2) is functionally identical to 3603-32 and differs only in front-panel screening and mounting orientation.

#### **CAUTION**

<p><b>Field repairs/modifications may void compliance with Underwriters Laboratories Standard 1459 – 2nd Edition. Compliance restricted to inside plant wiring.</b></p>
---

### 1.4 Equipment Location/Mounting

The 3603-02 is designed only for horizontal mounting in 19-inch mechanics 360 bank assemblies, while the 3603-32 (Equipment Issue 2) is designed only for vertical mounting in 23-inch mechanics 363 bank assemblies.

### 1.5 Equipment Features

The LIU-3E includes the following features:

- Provides DSX-1 interface to DS1 facility
- Pre-equalization to 655 feet of ABAM or GCC 4155 cable (or equivalent)
- Option for Free-Run, Loop Timed, or External Clock synchronization modes
- Accepts composite clock external timing input synchronization
- Front panel CCF and PCMF LEDs indicating failure of composite clock and incoming PCM, respectively
- Recognized under Underwriters Laboratories Standard 1459, Second Edition

## 2. INSPECTION

### 2.1 Inspect for Damages

Inspect the equipment thoroughly upon delivery. If the equipment has been damaged in transit, immediately report the extent of damage to the transportation company.

### 2.2 Equipment Identification

Charles Industries' equipment is identified by a model and issue number imprinted on the front panel or located elsewhere on the equipment. Each time a major engineering design change is made on the equipment, the issue number is advanced by 1 and imprinted on subsequent units manufactured. Therefore, be sure to include both the model number and its issue number when making inquiries about the equipment.

### 2.3 Static Concerns

Each module is shipped in static-protective packaging to prevent electrostatic charges from damaging static-sensitive devices. Use approved static-preventive measures, such as static-conductive wrist straps and a static-dissi-

protective mat, when handling modules outside of their protective packaging. A module intended for future use should be tested as soon as possible and returned to its original protective packaging for storage.



**STATIC-SENSITIVE**



**This equipment contains static-sensitive electronic devices. To prevent electrostatic charges from damaging static-sensitive units:**

- **Use approved static preventive measures (such as a static-conductive wrist strap and a static-dissipative mat) at all times whenever touching units outside of their original, shipped static-protective packaging.**
- **Do not ship or store units near strong electrostatic, electromagnetic, or magnetic fields.**
- **Use static-protective packaging for shipping or storage.**

### 3. APPLICATION GUIDELINES

The LIU–3E is always used with a 3608–XX Digroup Interface Unit (DIU). The LIU–3E/DIU set forms the basic, required common equipment for any 360/363 channel bank. Various types of DIU units may be used with the LIU–3E, depending on application requirements and channel bank mechanics.

The LIU–3E forms the common equipment interface between the DS1 facility and the associated Digroup Interface Unit (DIU). The LIU–3E interfaces to the DS1 facility at standard DSX–1 levels and provides an adjustable DSX–1 pre-equalizer in the transmit direction.

### 4. CIRCUIT DESCRIPTION

The LIU–3E extracts the clock from the incoming DS1 signal and generates the master system timing for the channel bank. If the channel bank is to be synchronized to a source of external composite clock, the LIU–3E accepts the clock input and synchronizes the channel bank's internal clock. If the LIU–3E is synchronized to the incoming DS1, the LIU–3E can be optioned to generate a composite clock signal output to other equipment, or to the other LIU in dual digroup channel bank assemblies.

The LIU–3E is equipped with front-panel-mounted bantam style test jacks to provide BIT and BYTE clock timing signal outputs to external test equipment for testing digital data channels.

The LIU–3E is also equipped with two front-panel-mounted LEDs, PCMF and CCF. The PCMF (PCM Fail) LED will illuminate whenever the LIU–3E has received more than 16 consecutive zeros on the receive DS1 facility. The CCF (Composite Clock Fail) LED will illuminate when the LIU–3E has been optioned to sync to an external composite clock and that clock has failed.

### 5. OPTIONS

The LIU–3E is equipped with slide switch options that are used to condition the module for proper application and operation. Refer to Figure 2 for option switch location while reading the following optioning instructions.

#### 5.1 T1 (DSX-1) Pre-Equalization (S2 and S3)

Option switches S2 and S3 are used to adjust the DS1 output level dependent on the distance from the channel bank to the DSX–1. Option per Table 1.

**Table 1. DS1 Transmit Line Equalizer Requirements**

LENGTH OF DS1 CABLE (FEET)		EQUALIZER OPTIONING	
GCC 4155(ABAM)	GCC 4162	S2 Position	S3 Position
0-110	0-92	PAD	any
111-220	93-183	EQ	111-220 FT
221-440	184-366	EQ	221-440 FT
441-655	367-544	EQ	441-655 FT

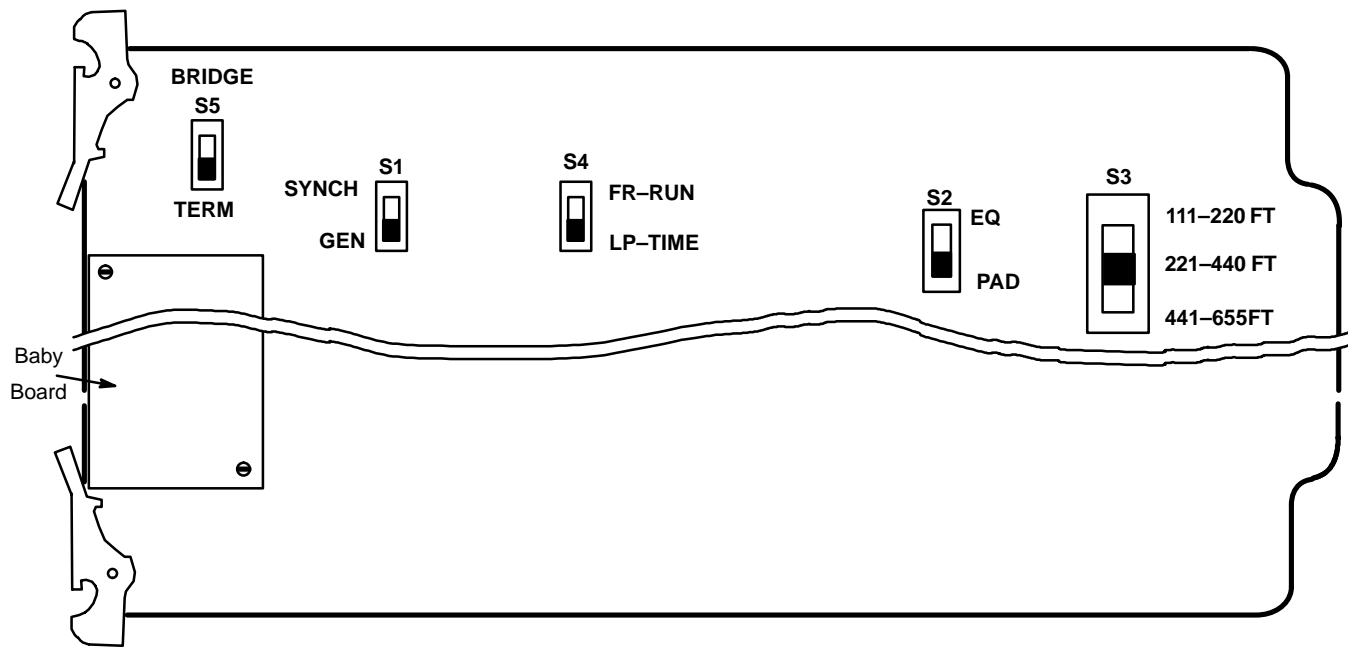

Figure 2. 3603-02/32 LIU-3E Option Locations

## 5.2 Synchronization/Timing (S1 and S4)

The LIU-3E can provide various system synchronization and clock timing modes. These modes are selected via slide switches S1 and S4. The mode selected is dependent upon the application.

### 5.2.1. FREE-RUN Mode

The simplest mode of operation is when two channel banks are connected via a DS1 facility. The two channel banks should be synchronized to each other. Either of the terminals, without preference, can be optioned to be the master clock by optioning its LIU-3E to the FREE-RUN mode. The LIU-3E of the other channel bank must be optioned for the LOOP-TIME mode.

### 5.2.2. LOOP-TIME Mode

If a channel bank is connected via a DS1 facility to a network element (or FAR end channel bank) which will provide the master timing, the LIU-3E should be optioned for LOOP-TIME mode. This arrangement is typical if the channel bank is used to access switched network services or is connected to a DCS (Digital Crossconnect System).

### 5.2.3. SYNC Mode

If the channel bank is to be synchronized to an external composite clock source, the LIU-3E should be optioned for SYNC mode. In this mode the external composite clock source must be connected to the composite clock input terminals of the bank assembly.

The 3603-02 LIU-3E provides two composite clock ports, as shown in Figure 3. Depending on the mode selected, port # 1 can either send or receive the 64KB composite clock, while port # 2 can only source the clock. Note that on some 360/363 channel bank assemblies only clock port # 1 is accessible for external connections. Set switches S1 and S4 as shown in Table 2.

## 5.3 Switch S5 Composite Clock Termination

When a source of composite clock is distributed to multiple channel banks, it is necessary to provide a termination resistance at one point in the chain. This termination should be provided at the bank location that is farthest from the timing supply output. In some 360/363 channel bank assemblies, this termination is part of the bank assembly in the form of a backplane subassembly, or a slide switch option on the rear of the shelf assembly.

If the channel bank assembly that houses the LIU-3E has an integral composite clock termination, and it is necessary to terminate the clock bus at this location, the bank termination should be used, and switch S5 on the LIU-3E PCB should be placed in the BRIDGE position.

If the channel bank assembly that houses the LIU-3E does not have an integral clock termination, and it is necessary to terminate the clock at this location, the termination located on the LIU-3E should be used by placing Switch S5 on the LIU-3E in the TERM position.

Table 2. Clock Control Mode Selection

Mode	Option Positions		Composite Clock Input/Output	
	S4	S1	PORT # 1 (Pin 61, 63)	PORT # 2 (Pin 62, 64)
Free Run	FR-RUN	GEN	OUTPUT	OUTPUT
Loop Time	LP-TIME	GEN	OUTPUT	OUTPUT
Sync	LP-TIME	SYNC	INPUT	DISABLED

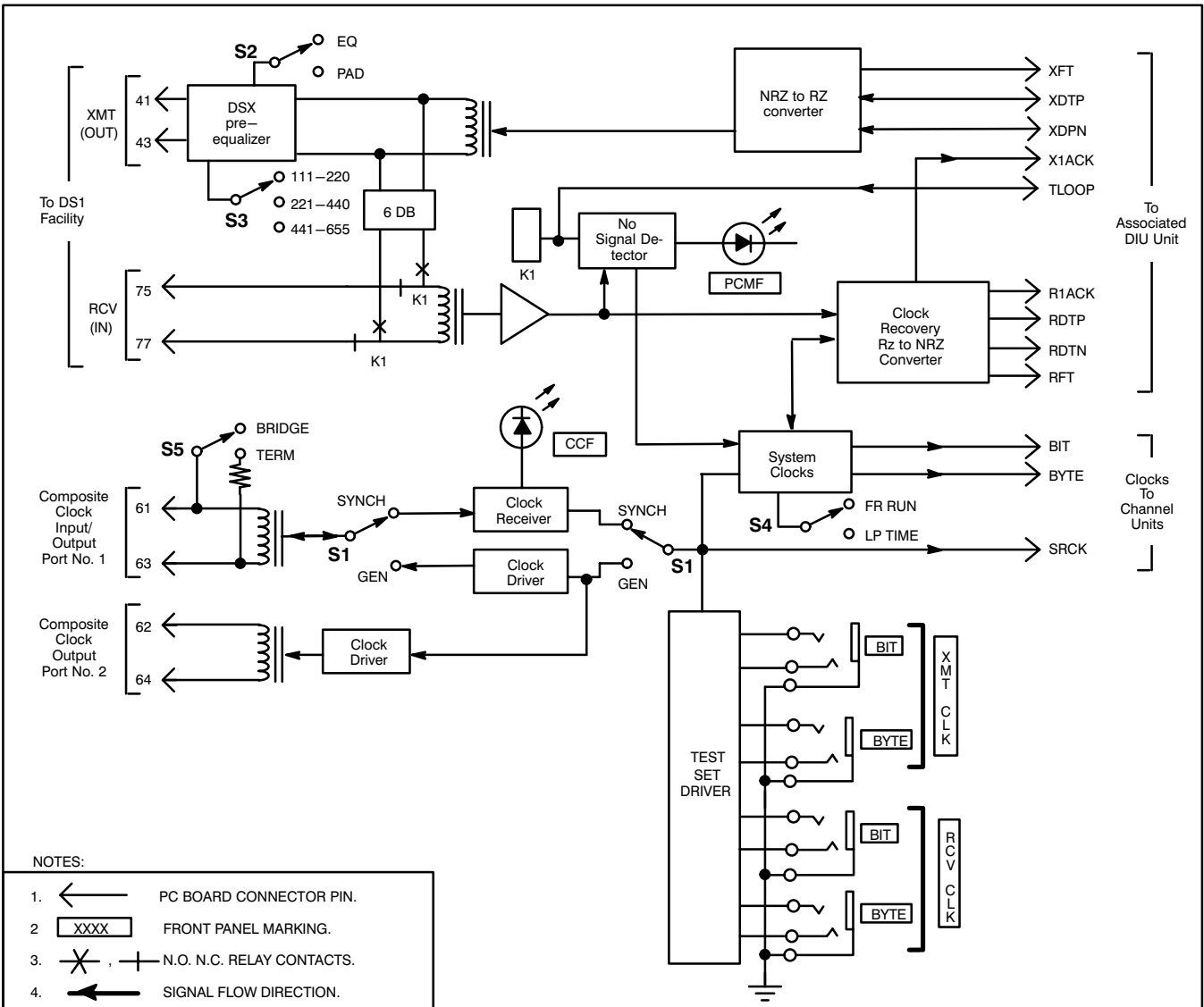

Figure 3. 3603-02/32 LIU-3E Block Diagram

## 6. MOUNTING

The LIU–3E mounts in a dedicated equipment slot in the channel bank assembly. Refer to the installation practice for the specific 360/363 assembly for the correct mounting location. Perform all option conditioning as described in Part 5 of this Practice before inserting the LIU–3E into its mounting slot of the channel bank.

### CAUTION

Installation and removal of modules should be done with care. Do not force a module into place. If excessive resistance is encountered while installing a module, remove the module and check the card guides and connector to verify proper alignment and the absence of foreign material.

## 7. TESTING

### 7.1 Common Equipment Testing

Refer to the turn–up and acceptance procedure Practice for the particular 360/363 channel bank that is being used.

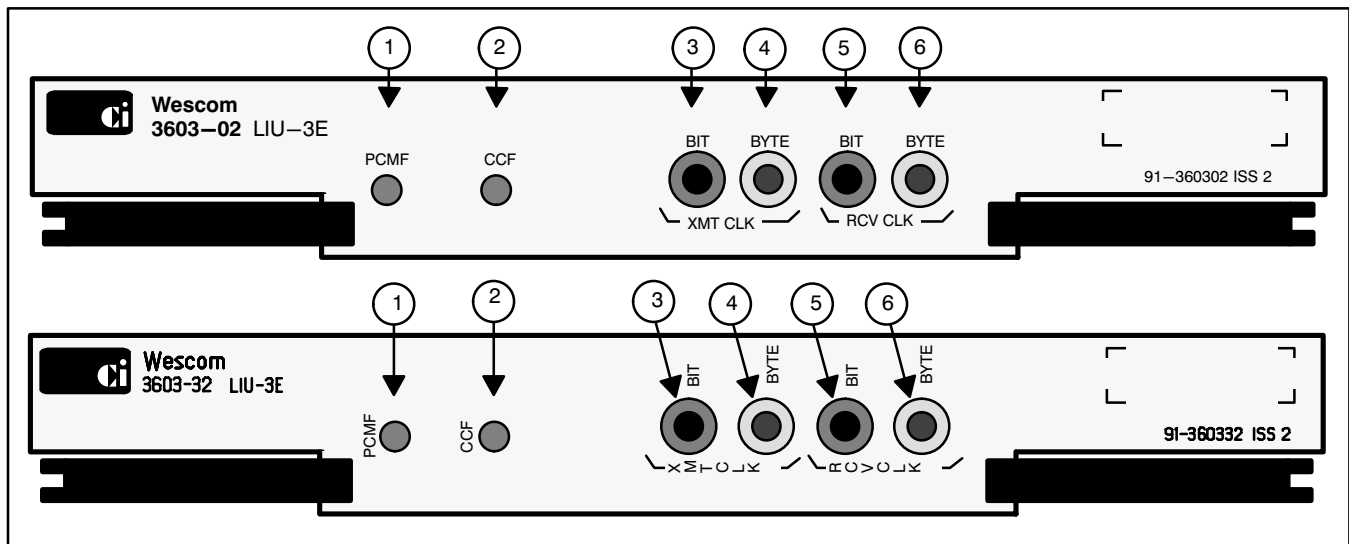

Figure 4. 3603-02/32 LIU-3E Front-Panel Layout

Table 3. 3603-02/32 LIU-3E Front-Panel Description

#	Front Panel Description	Function
1	PCMF	PCM (DS1/T1) SIGNAL FAILURE. This LED, when lit, indicates that the input DS1 signal is not present.
2	CCF	COMPOSITE CLOCK FAILURE INDICATOR (LED). This LED, when lit, indicates that the external source of composite clock has been lost.
3	XMT CLK–BIT	64kHz BIT CLOCK OUTPUT JACK
4	XMT CLK–BYTE	8kHz BYTE CLOCK OUTPUT JACK
5	RCV CLK–BIT	64kHz BIT CLOCK OUTPUT JACK
6	RCV CLK–BYTE	8kHz BYTE CLOCK OUTPUT JACK

## 8. TECHNICAL ASSISTANCE

If technical assistance is required, contact Charles Industries' Technical Services Center at:

847–806–8500  
 847–806–8556 (FAX)  
 800–607–8500  
 techserv@charlesindustries.com (e-mail)

## 9. WARRANTY & CUSTOMER SERVICE

### 9.1 Warranty

Charles Industries, Ltd. offers an industry-leading, 5-year warranty on products manufactured by Charles Industries. Contact your local Sales Representative at the address or telephone numbers below for warranty details. The warranty provisions are subject to change without notice. The terms and conditions applicable to any specific sale of product shall be defined in the resulting sales contract.

Charles Industries, Ltd.  
 5600 Apollo Drive  
 Rolling Meadows, Illinois 60008–4049  
 847–806–6300 (Main Office)  
 847–806–6231 (FAX)

### 9.2 Field Repairs (In-Warranty Units)

Field repairs involving the replacement of components within a unit are not recommended and may void the warranty and compatibility with any applicable regulatory or agency requirements. If a unit needs repair, contact Charles Industries, Ltd. for replacement or repair instructions, or follow the *Repair Service Procedure* below.

### 9.3 Advanced Replacement Service (In-Warranty Units)

Charles Industries, Ltd. offers an “advanced replacement” service if a replacement unit is required as soon as possible. With this service, the unit will be shipped in the fastest manner consistent with the urgency of the situation. In most cases, there are no charges for in-warranty repairs, except for the transportation charges of the unit and for a testing and handling charge for units returned with no trouble found. Upon receipt of the advanced replacement unit, return the out-of-service unit in the carton in which the replacement was shipped, using the pre-addressed shipping label provided. Call your customer service representative at the telephone number above for more details.

### 9.4 Standard Repair and Replacement Service (Both In-Warranty and Out-Of-Warranty Units)

Charles Industries, Ltd. offers a standard repair or exchange service for units either in- or out-of-warranty. With this service, units may be shipped to Charles Industries for either repair and quality testing or exchanged for a replacement unit, as determined by Charles Industries. Follow the *Repair Service Procedure* below to return units and to secure a repair or replacement. A handling charge applies for equipment returned with no trouble found. To obtain more details of this service and a schedule of prices, contact the CI Service Center at 217–932–5288 (FAX 217–932–2943).

#### *Repair Service Procedure*

1. Prepare, complete, and enclose a purchase order in the box with the equipment to be returned.
2. Include the following information:
  - Company name and address
  - Contact name and phone number
  - Inventory of equipment being shipped
  - Particulars as to the nature of the failure
  - Return shipping address

3. Ship the equipment, purchase order, and above-listed information, transportation prepaid, to the service center address shown below.  
  
CI Service Center  
503 N.E. 15th St., P.O. Box 339  
Casey, IL 62420–2054
4. Most repaired or replaced units will be returned within 30 or 45 days, depending on the product type and availability of repair parts. Repaired units are warranted for either 90 days from the date of repair or for the remaining unexpired portion of the original warranty, whichever is longer.

## **10. SPECIFICATIONS**

The physical and electrical characteristics of the 3603-02/32 LIU-3E are as follows:

### **10.1 Electrical**

#### **10.1.1. Transmit T1 Interface**

- (a) LINE RATE: 1.544Mb/s  $\pm$ 50b/s.
- (b) LINE CODE: Bipolar.
- (c) LINE IMPEDANCE: 100 ohms.
- (d) LOOP TIMING CAPTURE RANGE: 1.544Mb/s  $\pm$ 50b/s.
- (e) LOOP TIMING JITTER BANDWIDTH: 0.5Hz typical.
- (f) LOOP TIMING FREQUENCY MEMORY: The byte phase error will not exceed 30 microseconds during the first 2 seconds following a loss of T1 receive signal.

#### **10.1.2. Receive T1 Interface**

- (a) LINE RATE: 1.544Mb/s  $\pm$ 200b/s.
- (b) LINE CODE: Bipolar.
- (c) AMPLITUDE: 1.5 to 3.0 volt peak.

#### **10.1.3. DDS Composite Clock Output**

- (a) LINE CODE: Bipolar (alternating polarity) 64kHz with bipolar violations at an 8kHz rate.
- (b) BASELINE TO PEAK AMPLITUDE: 3.4 volts  $\pm$ 15 percent into a 130 ohm resistive termination.
- (c) PULSE WIDTH: 5/8 duty cycle, nominal.

#### **10.1.4. DDS Composite Clock Input**

- (a) AMPLITUDE: 1.5 to 4.0 volts peak. Maximum range using GCC4162 or ABAM, 1500 feet.
- (b) TERMINATING IMPEDANCE: 130 ohms  $\pm$ 10% at 32kHz with one to fourteen 3603-02/32 composite clock inputs bridged together.
- (c) DATA TEST SET CONNECTION: DDS bit clock (64KB/s) and byte clock (8kHz) signal outputs provided on front-panel jacks for supplying the clock input requirement of data test sets.



**10.2 Physical**

See Table 4 for the physical characteristics of the units.

**Table 4. Physical Specifications**

<b>Feature</b>	<b>U.S.</b>	<b>Metric</b>
Height (3603–02)	1.2 inches	3.05 centimeters
Height (3603–32)	8.5 inches	21.59 centimeters
Width (3603–02)	8.5 inches	21.59 centimeters
Width (3603–32)	1.2 inches	3.05 centimeters
Depth (both units)	10.2 inches	25.91 centimeters
Weight	10.5 oz.	298 grams
Temperature	32 to 122° F	0 to 50° C
Humidity	To 95% (no condensation)	

