

Charles Industries' Z02 Non-Louvered Vertical Broadband Housing provides mounting facilities and security for fiber taps and RF passive components used in Fiber-to-the-Home or coaxial-based access networks. These pedestals are molded from a polyethylene resin designed for outside plant environments, resisting impact, UV rays, and environmental degradation. Network access equipment can be affixed directly to the slotted thru-hole provisions integrated into the equipment mounting stake. In addition, optional bracket kits provide increased mounting flexibility to meet customer-specific needs and applications.

#### Installation:

The Z02 pedestal is engineered for self-supporting direct buried installation, with convenience and cost-effectiveness in mind. During installation, bury the pedestal base to the desired depth and backfill. The pedestal has a rectangular design to maximize the usable internal dome space when typically rectangular-shaped equipment is installed. The depth of the dome provides sufficient clearance to support the bend radius of fiber drops exiting a fiber terminal or coax drop cables leaving the RF directional tap. In addition, the dome height offers ample space for stacked interconnected directional taps with splitters and directional coupler housings in a single pedestal.

#### MARKETS SERVED:

- Telecom / FTTX
- Utility
- Wireless
- Broadband Cable



#### FEATURES

- BEAD/BABAA compliant product
- Molded polyethylene (PE) with ultraviolet U/V inhibitors to provide impact resistance, color stability, and long-life
- Standard housing color is light green; other colors can be requested
- Self-latching, dome locking system reduces unlocked pedestals and unwanted access
- Hex-head locking bolt for use with standard 7/16" CAN or terminal wrench
- Molded-in ground line for consistent installations
- Temporary drop access
- Custom nameplate options available
- Galvanized steel equipment mounting stake to support various equipment configurations



# Z02 Non-Louvered Vertical Broadband Housings

## DIMENSIONAL VIEWS

All dimensions are in inches

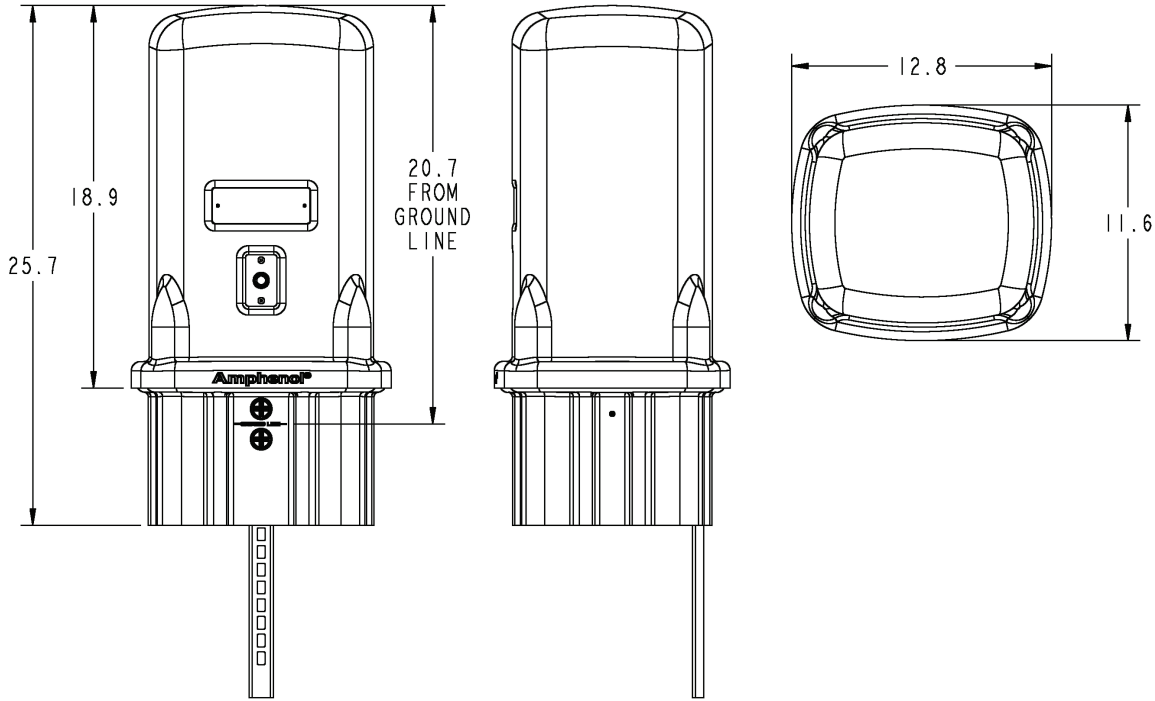

## STAKE TYPE

Galvanized steel equipment mounting stake features multiple position mounting holes arranged vertically along entire length of stake for convenient mounting of a variety of equipment.

## STANDARD PART NUMBERS

Part Number	Description	Pallet Qty.
Z02SS07-21000BK	Hex-head lock, light green housing, equipment mounting stake	24
Z02SS07-21024BK	Hex head-lock, light green housing, equipment mounting stake with C-bracket	24

Contact Charles Industries for additional available configurations and part numbers.



Looking for other BABA compliant products for BEAD funded projects? Please inquire with us for more information.

## Charles Industries, LLC

An Amphenol Company

1450 American Lane, 20th Floor, Schaumburg, IL 60173

[mktserv@charlesindustries.com](mailto:mktserv@charlesindustries.com)

(847) 806-6300

