

Amphenol Charles Industries' R02 Round Profile Non-Louvered Vertical Pedestal provides mounting facilities and security for fiber taps and RF passive components used in today's Fiber-to-the-Home or coaxial based access networks. The pedestal is engineered for installation with the included galvanized equipment mounting stake. Various access networking equipment can be affixed directly to the slotted thru-hole provisions integrated into the equipment mounting stake.

The R02 pedestal has a round profile dome which is selflatching for reduced chance of being left unlocked. The depth of the dome provides sufficient clearance to support the bend radius of fiber drops exiting a fiber terminal or coaxial drop cables exiting the RF directional tap. The overall dome height provides ample space for stacked interconnected directional taps with splitters and directional coupler housings in a single pedestal. These pedestals are molded from a polyethylene resin specifically designed for outside plant environments, resisting impact, ultraviolet and environmental degradation.

MARKETS SERVED:

- Telecom / FTTX
- Utility
- Wireless
- Broadband Cable



R02 Pedestal

FEATURES

- Molded of polyethylene (PE) with ultraviolet U/V inhibitors to provide impact resistance, color stability and long-life
- Standard housing color is light green, other colors are special order
- Self-latching, dome locking system reduces unlocked pedestals and unwanted access
- Hex-head locking bolt for use with standard 7/16" CAN or terminal wrench
- Molded-in ground line for consistent installations
- Temporary drop access feature
- Galvanized equipment mounting stake



R02 Non-Louvered Round Profile Vertical Broadband Pedestal

DIMENSIONAL VIEWS

All dimensions are in inches

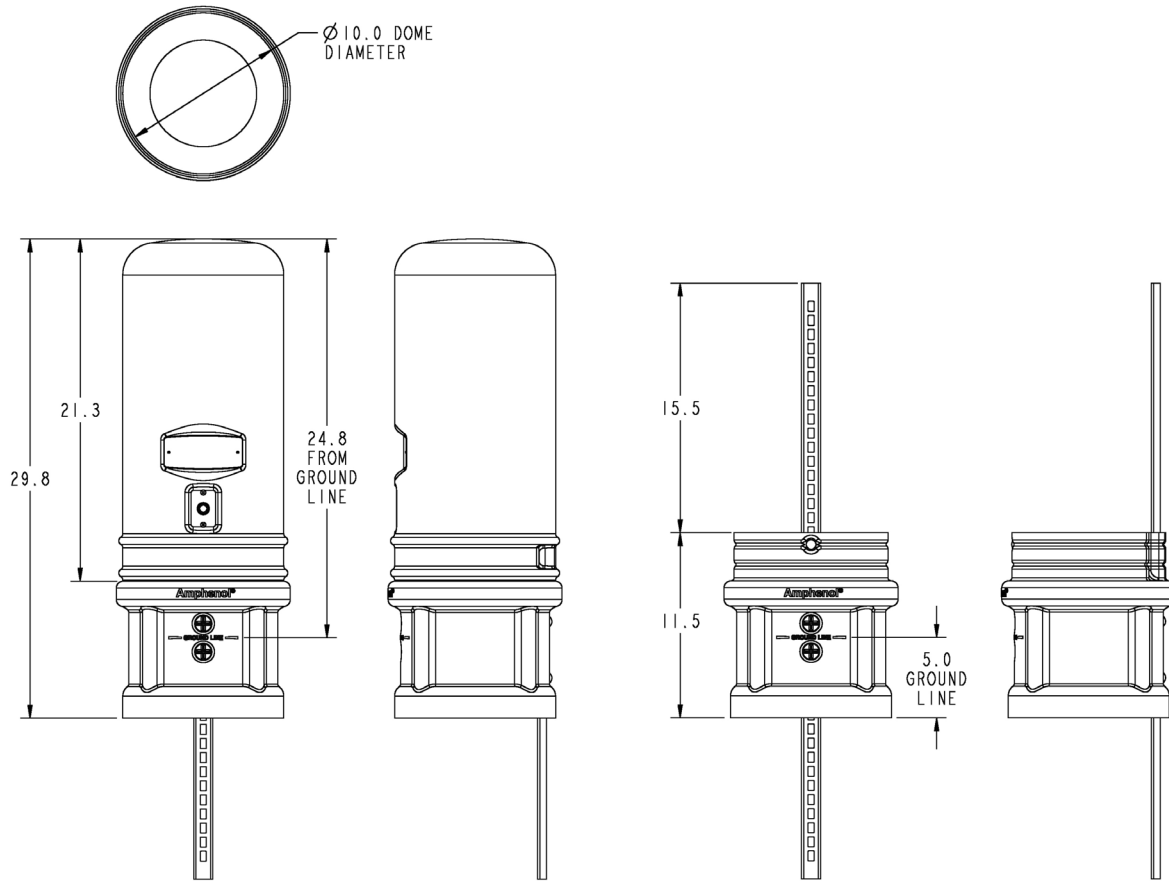

STAKE TYPE

Galvanized steel equipment mounting stake features multiple position mounting holes arranged vertically along entire length of stake for convenient mounting of a variety of equipment.

STANDARD PART NUMBERS

Part Number	Description	Pallet Qty.
R02SS07-21000BK	Hex-head lock, light green housing, equipment mounting stake	24

Contact Charles Industries for additional available configurations and part numbers.

Charles Industries, LLC

An Amphenol Company

1450 American Lane, 20th Floor, Schaumburg, IL 60173

 mkt serv@charlesindustries.com

 (847) 806-6300

