

# HVDL315 19-Inch Central Office Terminal Shelf Installation and Application Engineering

CONTENTS	PAGE
Part 1. GENERAL .....	2
Part 2. INSPECTION .....	3
Part 3. APPLICATION ENGINEERING .....	3
Part 4. MOUNTING .....	10
Part 5. INSTALLER CONNECTIONS .....	10
Part 6. TESTING .....	16
Part 7. TECHNICAL ASSISTANCE .....	17
Part 8. WARRANTY & CUSTOMER SERVICE .....	17
Part 9. SPECIFICATIONS & APPROVALS .....	18

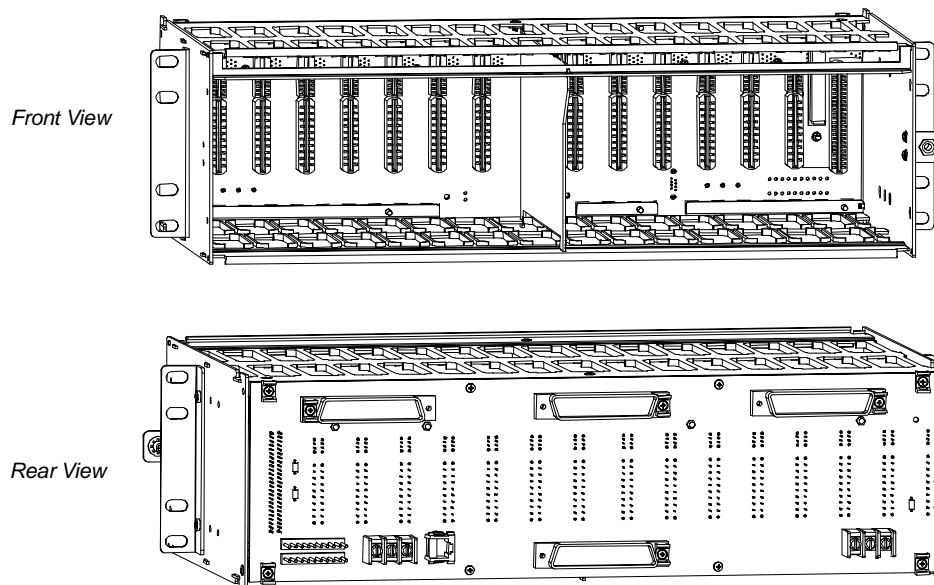

Figure 1. HVDL315 COT Shelf

## 1. GENERAL

### 1.1 Document Purpose

This document provides general, installation and application information for the HVDL315 Central Office Terminal (COT) shelf. A typical shelf is shown in Figure 1.

### 1.2 Document Status

This document is reprinted to clarify connector functions. See page 12.

### 1.3 Equipment Purpose and Location

The HVDL315 shelf is used to house the HVDL 3.1 COT line units and the HVDL381 Access Multiplexer. The HVDL315 is used in 19-inch racks, is 5<sup>1</sup>/<sub>4</sub>-inches high (3 rack units), and can be equipped with up to 15 COT LUs or 14 COT LUs and 1 Access Multiplexer. The shelf can be located in central office (CO) or controlled environment vault (CEV) racks, or in outside plant equipment cabinets. All Charles Industries HVD31X shelf and plug-in equipment is fully-qualified to operate over the outside plant equipment cabinet temperature range of –40 to +65°C. Table 1 provides a description of the shelf components.

**Table 1. HVDL315 COT Shelf Components**

Model #	Type	Function
HVDL315	COT Shelf	A rack-mounted 19-inch shelf installed in a CO, CEV or cabinet; it can contain up to 15 COT Line Units plus one alarm unit, or 14 COT line units and one Access Multiplexer.
HVDL381	Access Multiplexer/ COT Alarm Unit	A plug-in unit which provides data aggregation and alarm functions for the HVDL311 or HVDL315 COT shelf (one per shelf).
DDL381	COT Alarm Unit	A plug-in unit which performs common functions, such as alarm reporting, for the HVDL311 or HVDL315 COT shelf (one per shelf).
DDL392 or DDL393 or DDL393 List A	Dual POTS COT LU	A plug-in unit which connects 2 POTS lines from a co-located Class 5 CO switch or 2 lines from a digital loop carrier remote terminal to the 2-wire local loop digital subscriber line.
DMLQ34X	QuadPOTS COT LU	A plug-in unit which connects 4 POTS lines from a co-located Class 5 CO switch or 4 lines from a digital loop carrier remote terminal to the 2-wire local loop DSL, with or without a repeater.
DMLQ37X	POTS + BRI COT LU	A plug-in unit which connects 1 POTS line and 1 BRI line from a co-located Class 5 CO switch or 1 POTS and 1 BRI line from a digital loop carrier remote terminal to the 2-wire local loop DSL.
D56K32XX	56K Modem-Ready COT LU	A plug-in unit which provides an interface between two central office (CO) or digital loop carrier (DLC) remote terminal (RT) plain old telephone service (POTS) lines and a 2-wire digital subscriber line (DSL).
HVDL3XXXX	High-Speed Voice and Data Line COT LU	A plug-in unit which connects 3 voice lines from a co-located Class 5 CO switch plus 1 high speed data line to the 2-wire local loop DSL.

### 1.4 Features

The features of the HVDL315 COT shelf are as follows:

- Compact, high-density shelf
- 19-inch mechanics occupies 3 vertical rack units
- POTS, data, DSL, power, alarm, clock & miscellaneous cable connections available at shelf rear
- Shelf can be equipped with current POTS and HVDL line units, as well as future COT LU offerings.

## 2. INSPECTION

### 2.1 Inspect for Damages

Inspect the equipment thoroughly upon delivery. If the equipment has been damaged in transit, immediately report the extent of damage to the transportation company.

### 2.2 Equipment Identification

Charles Industries' equipment is identified by a model and issue number imprinted on the front panel or located elsewhere on the equipment. Each time a major engineering design change is made on the equipment, the issue number is advanced by 1 and imprinted on subsequent units manufactured. Therefore, be sure to include both the model number and its issue number when making inquiries about the equipment.

## 3. APPLICATION ENGINEERING

At the top of each rack, three rack units have been allocated for fuse, alarm and miscellaneous terminations. It is recommended that each bay be equipped with a dual feed fuse and distribution panel, with each feed supplying power to half of the HVDL315 shelves in the rack.

Charles Industries can supply factory-wired rack assemblies with your choice of rack power distribution panel and miscellaneous pair termination panels. Contact Charles Industries Technical Services for more information.

*Note: As a rule of thumb, if more than 20% of the cards in your system are of a higher heat-release type than the others, use the rack profiles for the higher heat-release type.*

### 3.1 HVDL with Access Multiplexer

Use the Charles FANHVDL19-A 300 CFM fan tray between every set of 2 shelves .

#### 3.1.1. Rack Profiles

See Figure 2 for HVDL with Access Multiplexer rack profiles.

#### 3.1.2. Heat Release and Current Consumption

Use Table 2 for HVDL systems with Access Multiplexer.

**Table 2. Heat Release and DC Current Consumption for HVDL Systems with Access Multiplexer**

19 Inch Rack Type	Configuration	Heat Release	DC Current Consumption (Amps)		
		Planning Value	Volts	Max.	Min.
	1 HVDL315 Shelf (14 HVDL COT LUs, 1 Access Multiplexer)	135.8 watts	52.0 42.5	4.6 5.6	3.3 3.6
7 feet	9 Shelves (126 COT LUs, 9 Access Multiplexers)	1222.2 watts	52.0 42.5	41.4 50.4	29.7 32.4
9 feet	15 Shelves (210 COT LUs, 15 Access Multiplexers)	2037 watts	52.0 42.5	69 84	49.5 54
11 feet, 6 inches	18 Shelves (252 COT LUs, 18 Access Multiplexers)	2444.4 watts	52.0 42.5	82.8 100.8	59.4 64.8

*Heat release values based on the following equipment configurations:*  
All COT LUs at maximum DSL loop of 1000 ohms. 8 REN load per system. 75% on-hook, 25% off-hook. Heat release calculations are for the central office only.

*DC current consumption values based on the following equipment configurations:*  
**MAX:** All lines off-hook, 8 REN load per system.  
**MIN:** All COT LUs at maximum DSL loop of 1000 ohms. 8 REN ringing load per system. All COT LUs idle.

**3.2 D56K Systems**

For D56K systems, a 300 CFM fan tray, such as the Charles FANDML-A, and a baffle should be used between every set of 2 shelves (see Figure 2).

**3.2.1. Rack Profiles**

See Figure 2 for D56K rack profiles.

**3.2.2. Heat Release and Current Consumption**

Use Table 3 for D56K systems.

**Table 3. Heat Release and DC Current Consumption for D56K**

19-Inch Rack Type	Configuration	Heat Release (Watts)			DC Current Consumption (Amps)		
		Busy	Idle	Planning Value	Volts	Max.	Min.
	1 Shelf (15 COT LUs)	161	87	104	52.0 42.5	3.7 5.0	1.4 1.9
7 feet	9 Shelves (135 COT LUs)	1449	783	936	52.0 42.5	33.3 45.0	12.6 17.1
9 feet	11 Shelves (165 COT LUs)	1771	957	1144	52.0 42.5	40.7 55.0	15.4 20.9
11 feet, 6 inches	15 Shelves (225 COT LUs)	2415	1305	1560	52.0 42.5	55.5 75.0	21.0 28.5

*Heat release values based on the following equipment configurations:*  
 All COT LUs at maximum DSL loop of 1300 ohms. 5 REN ringing load per channel.  
**BUSY:** All channels busy  
**IDLE:** All channels idle.  
**PLANNING VALUE:** 75% of channels idle, 20% busy, 5% ringing  
*DC current consumption values based on the following equipment configurations:*  
**MAX:** All COT LUs at maximum DSL loop of 1300 ohms. 5 REN ringing load per channel. All COT LUs busy.  
**MIN:** All COT LUs at maximum DSL loop of 1300 ohms. 5 REN ringing load per channel. All COT LUs idle.

Note: The vacant rack unit spaces shown are necessary for proper air convection and heat dissipation.

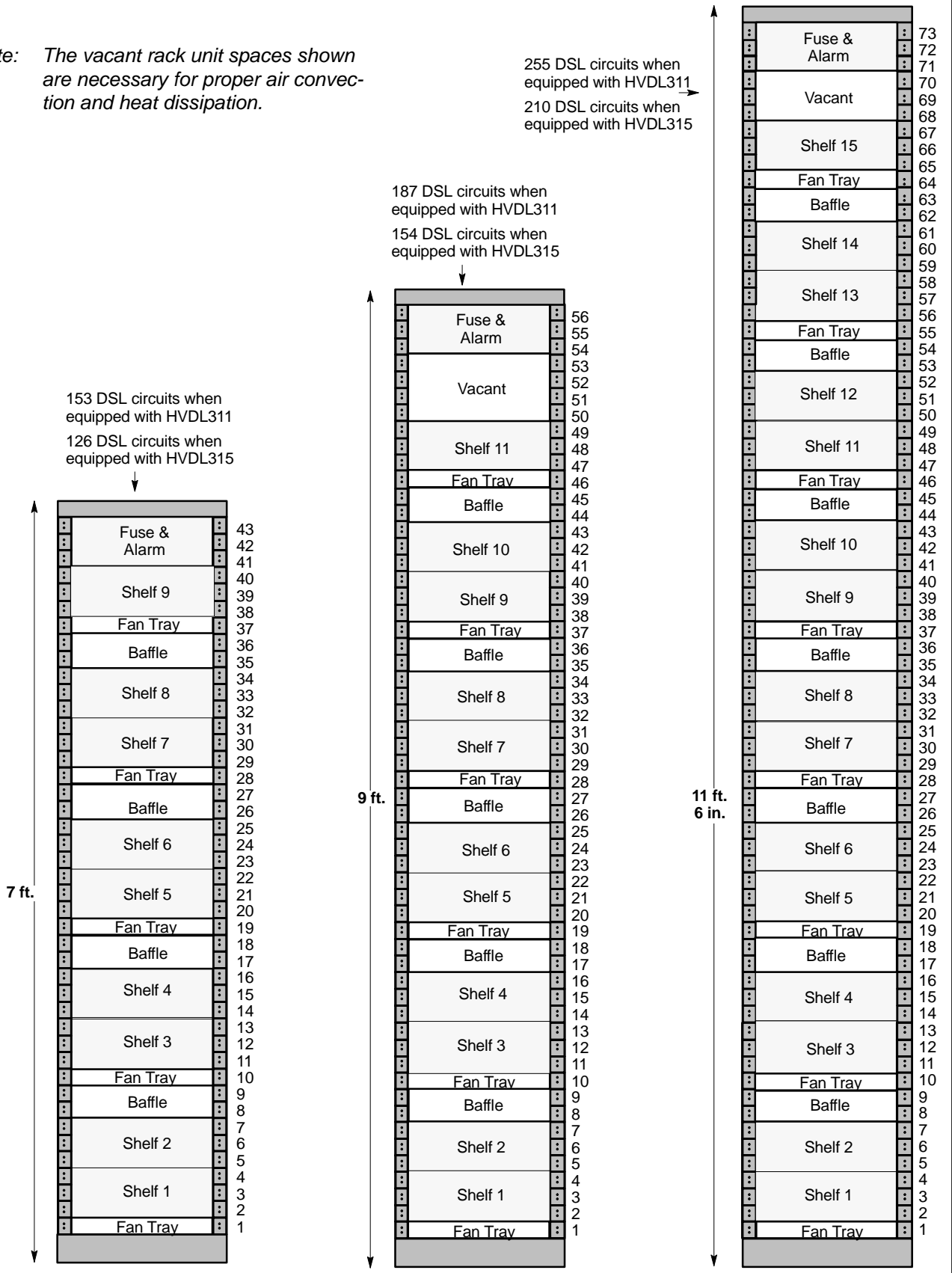

Figure 2. Fully Equipped Rack Profiles with HVDL31X Shelves and D56K or HVDL Cards (HVDL with Access Multiplexer)

3.3 DDL3XX Systems

3.3.1 Rack Profiles

See Figure 3 for DDL3XX rack profiles. It is very important to provide vacant spacing between groups of four shelves, as shown, to provide proper cooling of the equipment. A maximum of 13 shelves is recommended .

3.3.2 Heat Release and Current Consumption

Use the planning value shown in Table 4 to determine the average DDL frame heat release and DC current consumption.

Table 4. Heat Release and DC Current Consumption for DDL3XX

19-Inch Rack Type	Configuration	Heat Release (Watts)			DC Current Consumption (Amps)		
		Busy	Idle	Planning Value	Volts	Max.	Min.
	1 Shelf (15 COT LUs)	53	37	47	52.0	2.2	1.3
					42.5	2.6	1.6
7 feet	12 Shelves (180 COT LUs)	636	444	564	52.0	26.4	15.6
					42.5	31.2	19.2
9 feet	16 Shelves (240 COT LUs)	848	592	752	52.0	35.2	20.8
					42.5	41.6	25.6
11 feet, 6 inches	20 Shelves (300 COT LUs)	1060	740	940	52.0	44.0	26.0
					42.5	52.0	32.0

*Heat release values based on the following equipment configurations:*

**BUSY:** All COT LUs at maximum DSL loop of 1300 ohms. 5 REN ringing load per channel. 4 COT LUs with one channel ringing, one channel idle. 11 COT LUs with one channel busy, one channel idle.

**IDLE:** Same as BUSY above, but all channels idle.

**PLANNING VALUE:** Same as BUSY above, but only 5 COT LUs with one channel busy, one channel idle. 6 COT LUs idle. 4 COT LUs with one channel ringing, one channel busy.

*DC current consumption values based on the following equipment configurations:*

**MAX:** All COT LUs at maximum DSL loop of 1300 ohms. 4 COT LUs with one channel ringing, one channel idle. 11 COTs with one channel busy, one channel idle. 5 REN ringing load per channel.

**MIN:** All COT LUs at maximum DSL loop of 1300 ohms. 5 REN ringing load per channel. All COT LUs idle.

**Notes:**

The vacant rack unit spaces shown are necessary for proper air convection and heat dissipation.

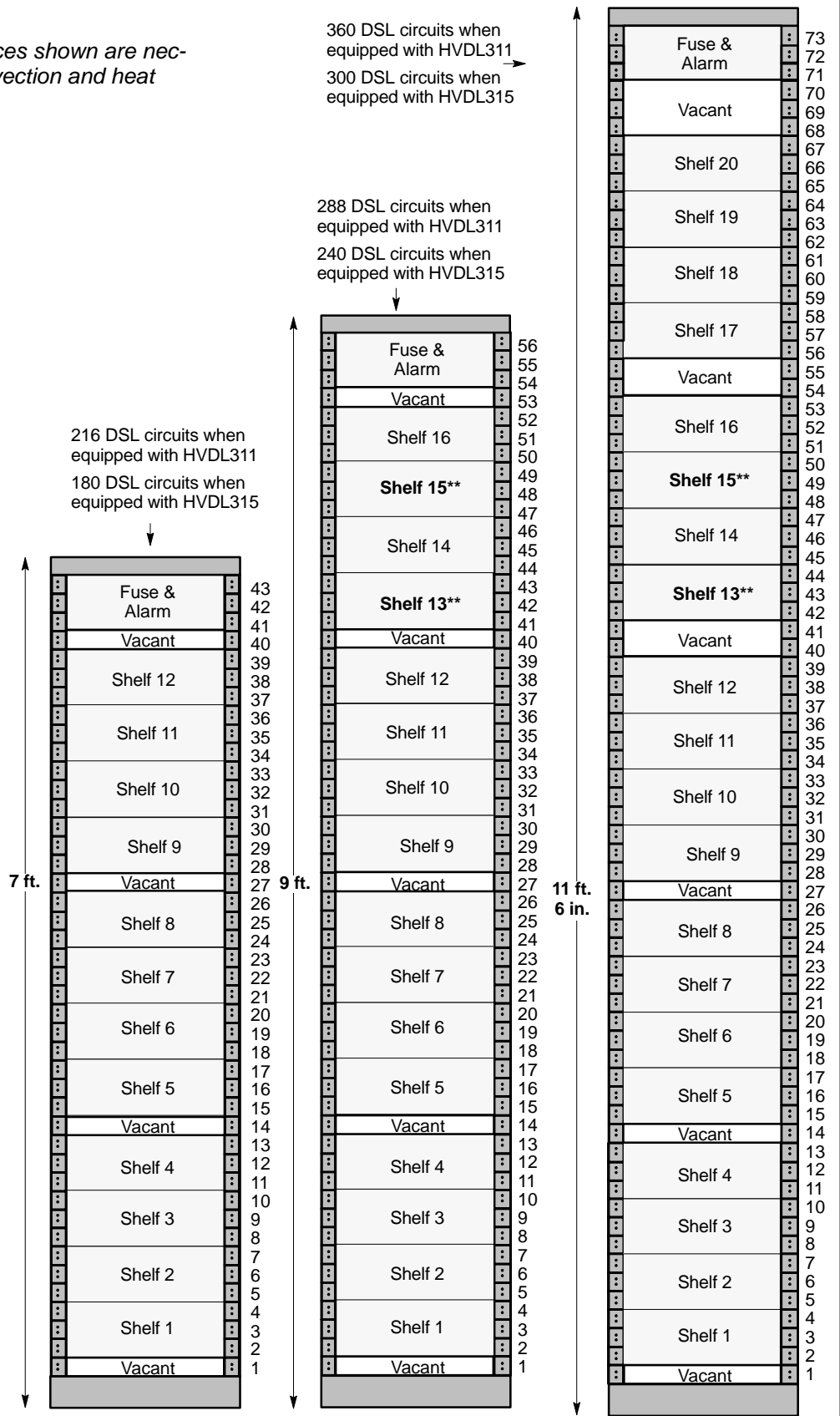

Figure 3. Fully Equipped Rack Profiles with HVD31X Shelves and DDL3XX Cards

**3.4 QuadPOTS or HVDL Systems**

For QuadPOTS or HVDL systems, a 300 CFM fan tray, such as the Charles FANHVDL19-A, should be used between every set of 3 shelves.

**3.4.1. Rack Profiles**

See Figure 4 for QuadPOTS or standard HVDL rack profiles.

**3.4.2. Heat Release and Current Consumption**

Use Table 5 for standard HVDL systems and QuadPOTS systems.

**Table 5. Heat Release and DC Current Consumption for HVDL and QuadPOTS Systems**

19-Inch Rack Type	Configuration	Heat Release (Watts)	DC Current Consumption (Amps)		
		Planning Value	Volts	Max.	Min.
	1 Shelf (15 COT LUs)	118.8	52.0 42.5	4.3 5.3	2.9 3.6
7 feet	9 Shelves (135 COT LUs)	1069.2	52.0 42.5	38.7 47.7	26.1 32.4
9 feet	15 Shelves (225 COT LUs)	1782.0	52.0 42.5	64.5 79.5	43.5 54.0
11 feet, 6 inches	18 Shelves (270 COT LUs)	2138.4	52.0 42.5	77.4 95.4	52.2 64.8
<b>For HVDL ONLY</b>	<p><i>Heat release values based on the following equipment configurations:</i>                      All COT LUs at maximum DSL loop of 1000 ohms. 8 REN load per system. 75% on-hook, 25% off-hook. Heat release calculations are for the central office only.</p> <p><i>DC current consumption values based on the following equipment configurations:</i>  <b>MAX:</b> All lines off-hook, 8 REN load per system.  <b>MIN:</b> All COT LUs at maximum DSL loop of 1000 ohms. 8 REN ringing load per system. All COT LUs idle.</p>				
<b>For Quad-POTS ONLY</b>	<p><i>Heat release values based on the following equipment configurations:</i>                      All COT LUs at maximum DSL loop of 1300 ohms. 12 REN load per system. 75% on-hook, 25% off-hook. Calculations are for central office only.</p> <p><i>DC current consumption values based on the following equipment configurations:</i>  <b>MAX:</b> All lines off-hook, 12 REN load per system.  <b>MIN:</b> All COT LUs at maximum DSL loop of 1300 ohms. 12 REN ringing load per system. All COT LUs idle.</p>				



Note: The vacant rack unit spaces shown are necessary for proper air convection and heat dissipation.

324 circuits when equipped with HVDL311  
 270 circuits when equipped with HVDL315

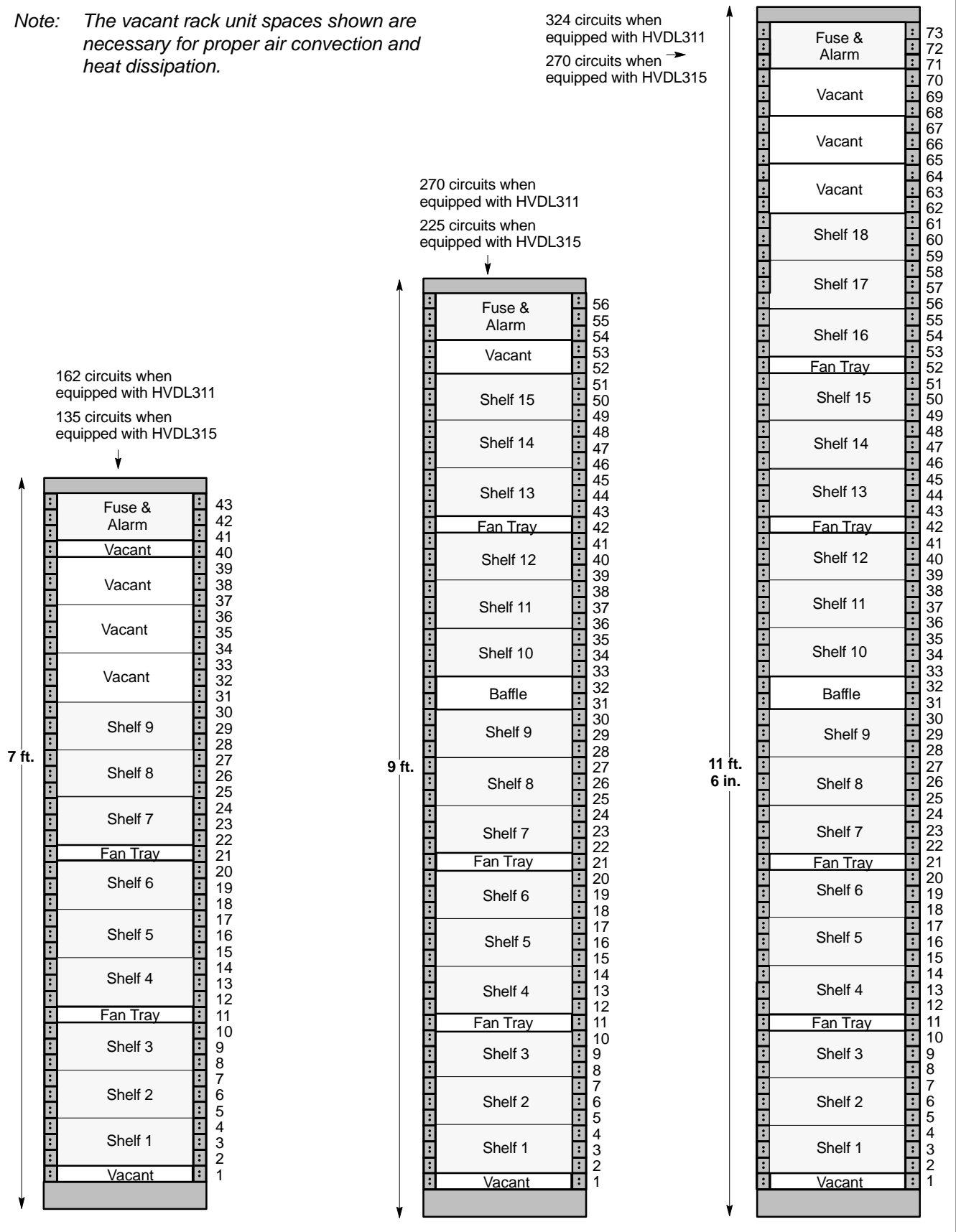

Figure 4. Fully Equipped Rack Profiles with HVD31X Shelves and QuadPOTS/HVDL Cards

## 4. MOUNTING

HVDL315 shelves are available to mount in 19-inch rack assemblies. The shelves have mounting holes to accommodate either 1.75-inch or 2-inch rack drilling.

### 4.1 Central Office or Controlled Environment Vault Mounting

In central office (CO) or controlled environment vaults (CEV) applications, dedicated frames can be allocated to HVDL315 shelves. Mounting spaces must be provided between HVDL315 shelves for proper cooling. Recommended rack configuration depends on the type of line units installed.

### 4.2 Cabinet Mounting

In cabinet assemblies, HVDL315 shelves are usually miscellaneously mounted with other equipment such as digital loop carrier remote terminals. Since vertical rack space is usually very limited in these assemblies, it is desirable to mount equipment assemblies as close as possible while maintaining adequate airflow for equipment cooling. To achieve acceptable thermal system performance in outside plant cabinets use the following guidelines.

- Limit the cabinet vertical mounting space to three (3) shelves
- Mount the equipment as low as possible in the cabinet assembly
- Provide a minimum of one 1.75-inch mounting space *below* the equipment and fan tray for proper cooling
- Provide a minimum of one 1.75-inch mounting space *above* the equipment for proper cooling
- Mounted the fan tray flush to the bottom of the shelf

Observing the above guidelines should result in adequate thermal performance. These guidelines are not a substitute for proper thermal analysis of any particular cabinet application. Thermal analysis of a particular cabinet application ensures that the HVDL315 equipment will remain within its specified ambient temperature range.

### 4.3 Mounting Orientation

HVDL315 equipment shelves contain adjustable mounting ears. The shelves are shipped from the factory with adjustable ears in the standard 5-inch front projection position. The mounting ears can be adjusted to front projections up to 7 inches. Refer to Figure 5.

In CEV applications, “reversed” unequal flange duct bays are often used. All HVDL315 shelves with their standard 5-inch front projection can be used in these front load applications. See Figure 5.

In some applications, it may be necessary to rear load HVDL315 shelves in unequal flange duct bays, as shown in the upper-right corner of Figure 5. In this application, reverse the mounting ears and change their locations as shown. In addition, remove the static wrist strap jack mounted on the right-hand side of the shelf.

## 5. INSTALLER CONNECTIONS

The shelves are prewired and connectorized to support up to 5 pairs per shelf slot. One pair is dedicated to the digital subscriber line (DSL). The other four pairs can be used to support various service interfaces, depending on what kind of card is plugged in to each slot.

After the cables have been connected to the shelf and terminated on connecting blocks at an intermediate distribution frame, any combination of service interfaces can be supported (up to four POTS lines per slot) by running the appropriate jumpers from the connecting blocks to the main distribution frame. There are no changes required at the 300 series shelf or the cables connected to it, other than plugging in the desired line card. Connecting blocks with 20 rows of 5 connectors each are available, which are ideal for this application.

### CAUTION

**Do not make any connections with power applied to the equipment or modules installed in the mounting assembly.**

### CAUTION

**Voltages up to  $\pm 130$  volts DC ( $\pm 80$  volts when using a DDL393 List A COT line unit) exist on the digital subscriber line (DSL). Always exercise caution when wiring a live circuit or when performing maintenance. Unplugging the COT line unit from the COT shelf will remove the voltages from the DSL.**

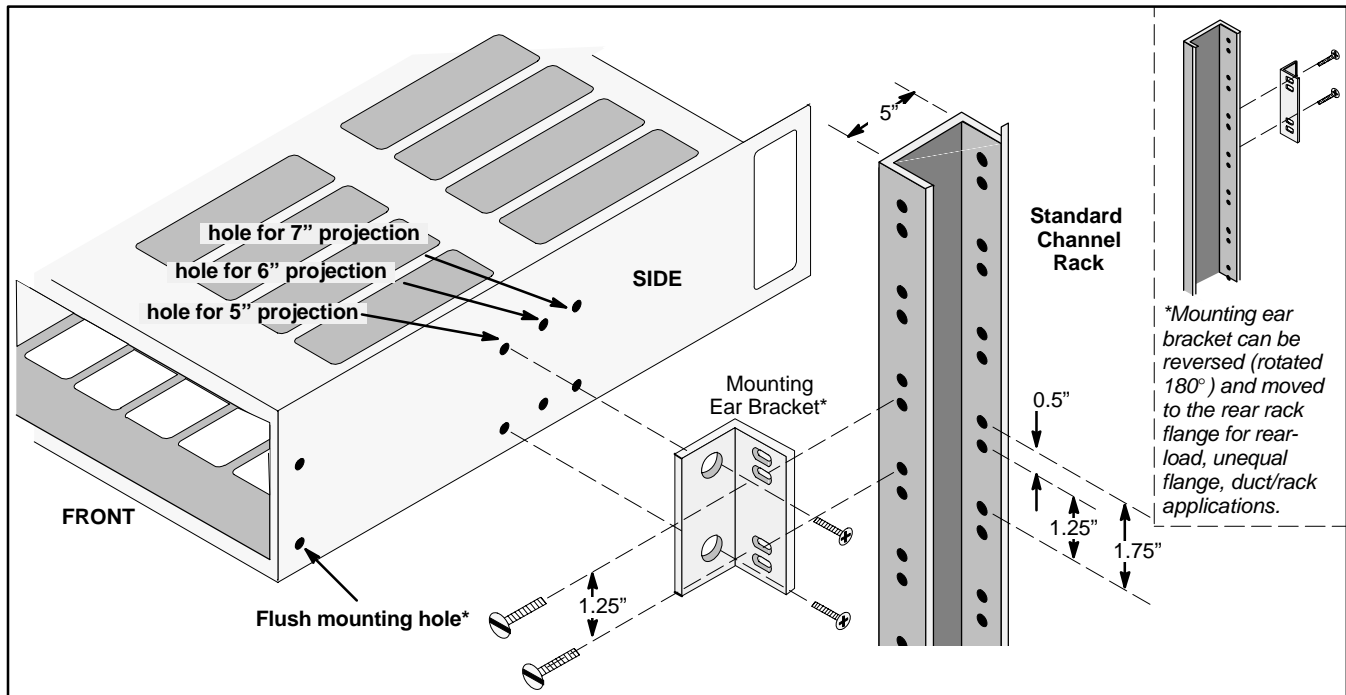

Figure 5. Shelf Mounting Ear Bracket Position for Standard Front Mount

### CAUTION

Installation and removal of channel units should be done with care. Use static-preventive measures when handling. Do not force a unit into place. If excessive resistance is encountered during installation, remove the unit and check the card guides and connector to verify proper alignment and the absence of foreign material.

## 5.1 Signal Leads

The derived POTS, data line pairs and DSL pairs are available through four 25-pair, male, "Amphenol" plugs on the rear of each HVDL315 shelf. P1, P2, and P3 provide all derived pairs, while P4 provides the DSL pairs to the cable facility. Obtain the appropriate type 25-pair cables for the DSL lines and the POTS and digital data lines between the COT shelf and the frame. Connect the cables to the appropriate 25-pair Amphenol-type female connectors. Secure the connectors to the P1 through P4 male connectors on the shelf backplane and terminate the other end of the cables at the frame. Figure 6 shows the locations of P1 through P4. Detailed information is provided in Table 6 and Table 7.

## 5.2 ALARM and MISC Connections

Wire wrap connections are made to the two 10-pin connectors, P5 and P6, located at the rear of the HVDL315 shelf, as shown in Figure 6. Alarm wiring can be made with solid 22 or 24 AWG wire. Figure 8 shows the ALARM and MISC connections to P5 and P6 when the shelf is equipped with the DDL381 Alarm unit or HVDL Access Multiplexer. Position 10 (CCK) of P5 and P6 are inputs for the office composite clock. The office clock is not required. If multiple HVDL315 shelves are served by the same central office composite clock source, terminal block TB2 must have its jumper in the proper position (TERMINATED or UNTERMINATED). If the composite clock connections are daisy-chained from one shelf to another, the jumper on all shelves except the last one in the chain should be set to UNTERMINATED. The jumper on the last shelf in the chain should be set to TERMINATED.

## 5.3 Power Connections

Power connections are made to the three-position terminal block, TB1, located on the rear of the HVDL315, shelf as shown in Figure 6. The -48V and GND connections should be made with 14 AWG (red and black) stranded wire to the top of the bay fuse panel. The FRG connections should be made with 14 AWG (green) stranded wire to the rack framework.

Each -48V BATT circuit must be fused with a 7.5-amp distribution fuse (10-amp distribution fuse for QuadPOTS/HVDL and D56K) in the top of the rack panel, as shown in Figure 7.

5.4 Connectors

Connector	Function
J1–J15	Main connectors. Required for shelf cards.
J16	Alarm Card or Access Multiplexer card connector.
J17–J31	Used on some of the newer cards. May be needed depending on the installation.
J32	Do not make any connections to this jack.

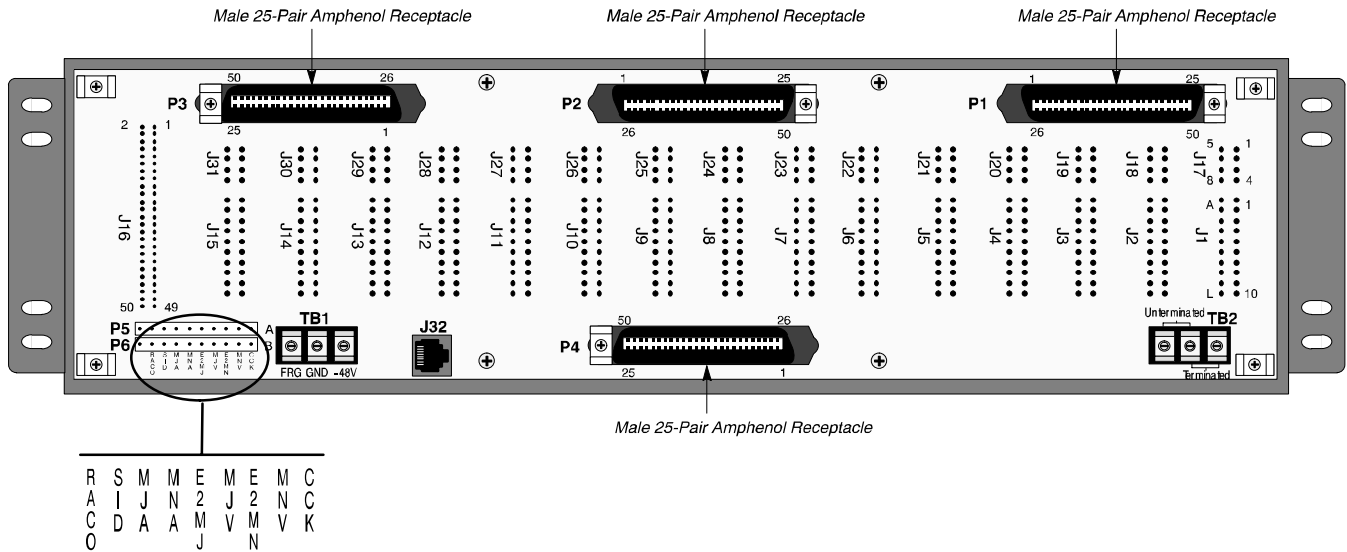
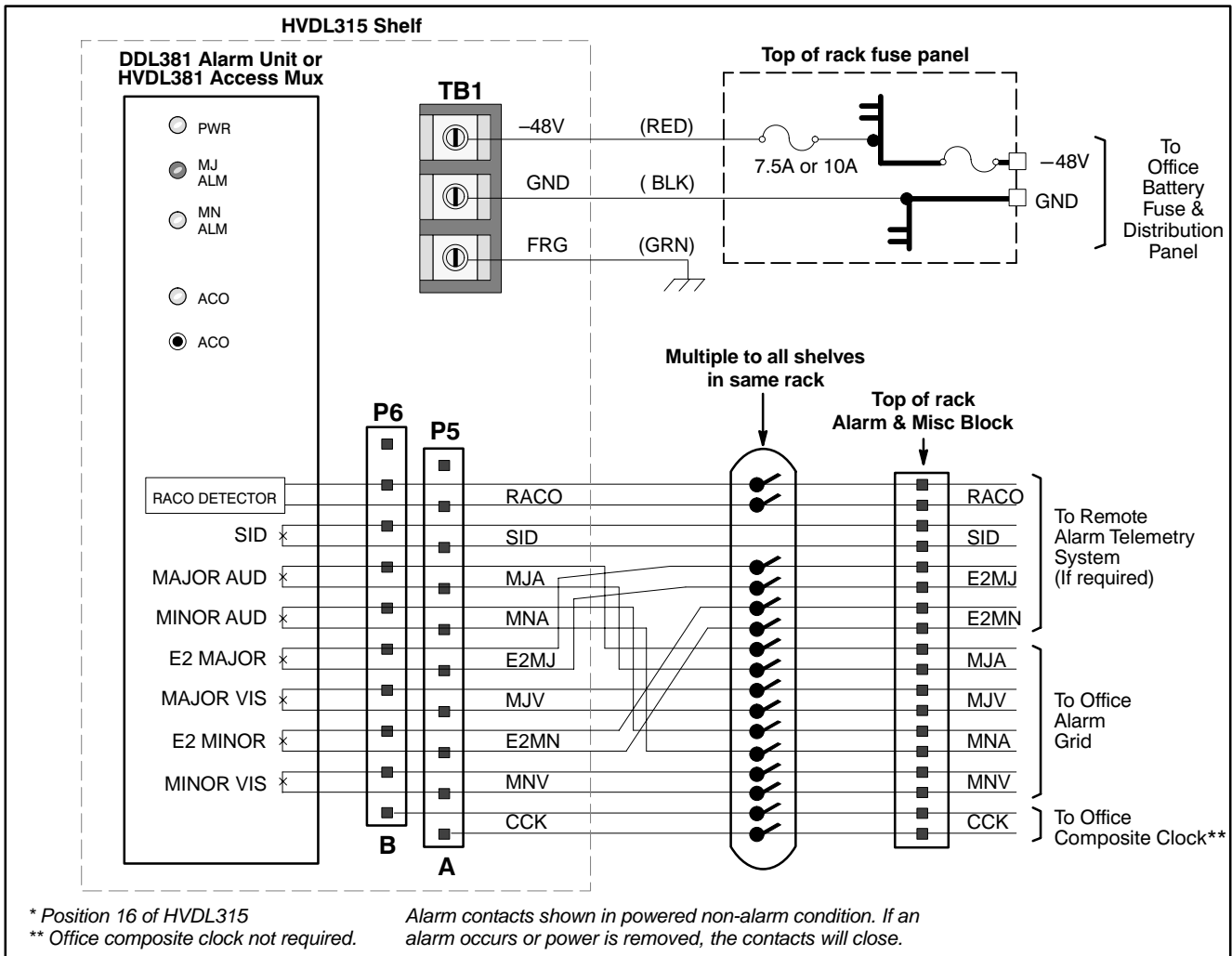

Figure 6. HVDL315 Rear View



**Figure 7. TB1, P5, and P6 Pin-outs**

*Note: Line 1 is always considered the "physical" pair in the HVDL315 shelf (compared to analog AML shelves, where line 1 may be considered the derived pair).*

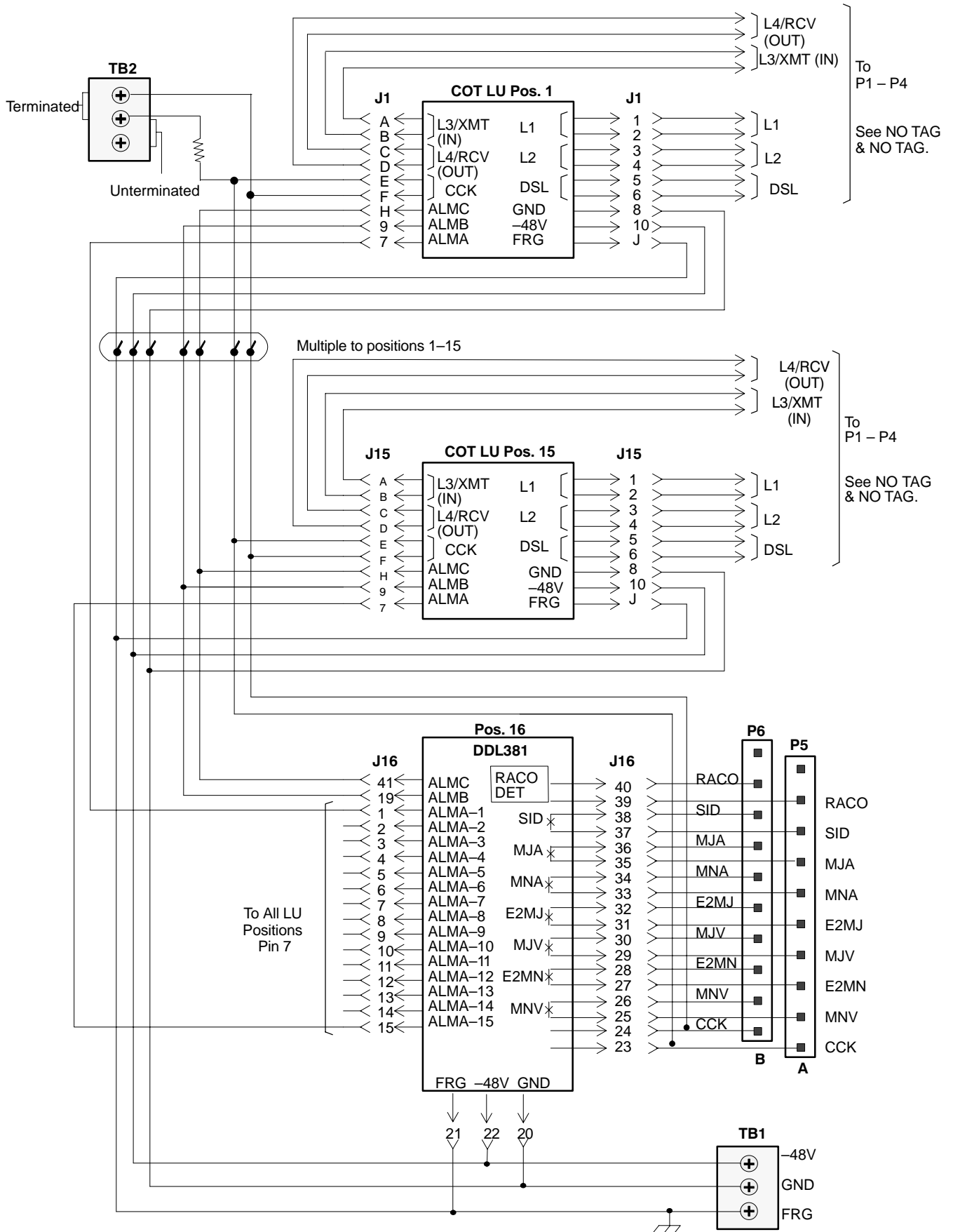

Figure 8. HVDL315 Shelf Wiring Diagram

Table 6. P1 and P2 Shelf Connectors (Derived Pairs)

P1 SHELF CONNECTOR				P2 SHELF CONNECTOR			
Shelf Circuit	P/O Shelf Wiring	Installer Cable To Dist. Frame	Circuit Name	Shelf Circuit	P/O Shelf Wiring	Installer Cable To Dist. Frame	Circuit Name
1	—> 26 >— —> 01 >—		L1	7	—> 26 >— —> 01 >—		L1
	—> 27 >— —> 02 >—		L2		—> 27 >— —> 02 >—		L2
	—> 28 >— —> 03 >—		L3 XMT (IN)		—> 28 >— —> 03 >—		L3 XMT (IN)
	—> 29 >— —> 04 >—		L4 RCV (OUT)		—> 29 >— —> 04 >—		L4 RCV (OUT)
2	—> 30 >— —> 05 >—		L1	8	—> 30 >— —> 05 >—		L1
	—> 31 >— —> 06 >—		L2		—> 31 >— —> 06 >—		L2
	—> 32 >— —> 07 >—		L3 XMT (IN)		—> 32 >— —> 07 >—		L3 XMT (IN)
	—> 33 >— —> 08 >—		L4 RCV (OUT)		—> 33 >— —> 08 >—		L4 RCV (OUT)
3	—> 34 >— —> 09 >—		L1	9	—> 34 >— —> 09 >—		L1
	—> 35 >— —> 10 >—		L2		—> 35 >— —> 10 >—		L2
	—> 36 >— —> 11 >—		L3 XMT (IN)		—> 36 >— —> 11 >—		L3 XMT (IN)
	—> 37 >— —> 12 >—		L4 RCV (OUT)		—> 37 >— —> 12 >—		L4 RCV (OUT)
4	—> 38 >— —> 13 >—		L1	10	—> 38 >— —> 13 >—		L1
	—> 39 >— —> 14 >—		L2		—> 39 >— —> 14 >—		L2
	—> 40 >— —> 15 >—		L3 XMT (IN)		—> 40 >— —> 15 >—		L3 XMT (IN)
	—> 41 >— —> 16 >—		L4 RCV (OUT)		—> 41 >— —> 16 >—		L4 RCV (OUT)
5	—> 42 >— —> 17 >—		L1	11	—> 42 >— —> 17 >—		L1
	—> 43 >— —> 18 >—		L2		—> 43 >— —> 18 >—		L2
	—> 44 >— —> 19 >—		L3 XMT (IN)		—> 44 >— —> 19 >—		L3 XMT (IN)
	—> 45 >— —> 20 >—		L4 RCV (OUT)		—> 45 >— —> 20 >—		L4 RCV (OUT)
6	—> 46 >— —> 21 >—		L1	12	—> 46 >— —> 21 >—		L1
	—> 47 >— —> 22 >—		L2		—> 47 >— —> 22 >—		L2
	—> 48 >— —> 23 >—		L3 XMT (IN)		—> 48 >— —> 23 >—		L3 XMT (IN)
	—> 49 >— —> 24 >—		L4 RCV (OUT)		—> 49 >— —> 24 >—		L4 RCV (OUT)

Table 7. P3 Shelf Connector (Derived Pairs) and P4 Shelf Connector (DSL Pairs)

P3 SHELF CONNECTOR				P4 SHELF CONNECTOR			
Shelf Circuit	P/O Shelf Wiring	Installer Cable To Dist. Frame	Circuit Name	Shelf Circuit	P/O Shelf Wiring	Installer Cable To Dist. Frame	Circuit Name
13	—> 26 >— —> 01 >—		L1	1	—> 26 >— —> 01 >—		DSL
	—> 27 >— —> 02 >—		L2	2	—> 27 >— —> 02 >—		DSL
	—> 28 >— —> 03 >—		L3 XMT (IN)	3	—> 28 >— —> 03 >—		DSL
	—> 29 >— —> 04 >—		L4 RCV (OUT)	4	—> 29 >— —> 04 >—		DSL
14	—> 30 >— —> 05 >—		L1	5	—> 30 >— —> 05 >—		DSL
	—> 31 >— —> 06 >—		L2	6	—> 31 >— —> 06 >—		DSL
	—> 32 >— —> 07 >—		L3 XMT (IN)	7	—> 32 >— —> 07 >—		DSL
	—> 33 >— —> 08 >—		L4 RCV (OUT)	8	—> 33 >— —> 08 >—		DSL
15	—> 34 >— —> 09 >—		L1	9	—> 34 >— —> 09 >—		DSL
	—> 35 >— —> 10 >—		L2	10	—> 35 >— —> 10 >—		DSL
	—> 36 >— —> 11 >—		L3 XMT (IN)	11	—> 36 >— —> 11 >—		DSL
	—> 37 >— —> 12 >—		L4 RCV (OUT)	12	—> 37 >— —> 12 >—		DSL
				13	—> 38 >— —> 13 >—		DSL
				14	—> 39 >— —> 14 >—		DSL
				15	—> 40 >— —> 15 >—		DSL

## 6. TESTING

Testing can be done after all connections are made to P1 through P4, TB1, and TB2. After verifying that no plug-in units are equipped in any shelf positions, perform the following steps.

Step	Action
1.	Place a 7.5 amp fuse (10 amp for QuadPOTS, standard HVDL and D56K systems) in the top of the bay fuse and distribution panel for the shelf to be tested.
2.	With a voltmeter, verify the –48V and GND on TB1 is –48V (nominal) and the correct polarity.
3.	Insert an alarm unit in the shelf alarm position and verify that its green power LED is on.
4.	Repeat Steps 1 through 3 for all other shelves in the rack

If trouble is encountered with the operation of the unit, verify that all installer connections have been made properly, and that all options have been conditioned as required.



## 7. TECHNICAL ASSISTANCE

If technical assistance is required, contact Charles Industries' Technical Services Center at:

847-806-8500

847-806-8556 (FAX)

800-607-8500

techserv@charlesindustries.com (e-mail)

## 8. WARRANTY & CUSTOMER SERVICE

### 8.1 Warranty

Charles Industries, Ltd. offers an industry-leading, 5-year warranty on products manufactured by Charles Industries. Contact your local Sales Representative at the address or telephone numbers below for warranty details. The warranty provisions are subject to change without notice. The terms and conditions applicable to any specific sale of product shall be defined in the resulting sales contract.

Charles Industries, Ltd.

5600 Apollo Drive

Rolling Meadows, Illinois 60008-4049

847-806-6300 (Main Office)

847-806-6231 (FAX)

### 8.2 Field Repairs (In-Warranty Units)

Field repairs involving the replacement of components within a unit are not recommended and may void the warranty and compatibility with any applicable regulatory or agency requirements. If a unit needs repair, contact Charles Industries, Ltd. for replacement or repair instructions, or follow the *Repair Service Procedure* below.

### 8.3 Advanced Replacement Service (In-Warranty Units)

Charles Industries, Ltd. offers an "advanced replacement" service if a replacement unit is required as soon as possible. With this service, the unit will be shipped in the fastest manner consistent with the urgency of the situation. In most cases, there are no charges for in-warranty repairs, except for the transportation charges of the unit and for a testing and handling charge for units returned with no trouble found. Upon receipt of the advanced replacement unit, return the out-of-service unit in the carton in which the replacement was shipped, using the pre-addressed shipping label provided. Call your customer service representative at the telephone number above for more details.

### 8.4 Standard Repair and Replacement Service (Both In-Warranty and Out-Of-Warranty Units)

Charles Industries, Ltd. offers a standard repair or exchange service for units either in- or out-of-warranty. With this service, units may be shipped to Charles Industries for either repair and quality testing or exchanged for a replacement unit, as determined by Charles Industries. Follow the *Repair Service Procedure* below to return units and to secure a repair or replacement. A handling charge applies for equipment returned with no trouble found. To obtain more details of this service and a schedule of prices, contact the CI Service Center at 217-932-5288 (FAX 217-932-2943).

#### *Repair Service Procedure*

1. Prepare, complete, and enclose a purchase order in the box with the equipment to be returned.
2. Include the following information:
  - Company name and address
  - Contact name and phone number
  - Inventory of equipment being shipped
  - Particulars as to the nature of the failure
  - Return shipping address

3. Ship the equipment, purchase order, and above-listed information, transportation prepaid, to the service center address shown below.  
  
 CI Service Center  
 503 N.E. 15th St., P.O. Box 339  
 Casey, IL 62420-2054
4. Most repaired or replaced units will be returned within 30 or 45 days, depending on the product type and availability of repair parts. Repaired units are warranted for either 90 days from the date of repair or for the remaining unexpired portion of the original warranty, whichever is longer.

**9. SPECIFICATIONS**

The physical specifications of the HVDL315 are shown in Table 8.

**Table 8. HVDL315 Physical Specifications**

<b>Feature</b>	<b>U.S.</b>	<b>Metric</b>
Height	5.25 inches	13.3 centimeters
Width	19.13 inches	48.6 centimeters
Depth	12 inches	30.5 centimeters
Weight	10 pounds	4.5 kilograms
Temperature	-40 to +149°F	-40 to +65°C
Humidity	To 95% (no condensation)	

