

# AC 2307 Seven-Slot T1 Mini Repeater Apparatus Case

CLEI™ Code: T1RCWUG5

 Complies with Underwriters Laboratories Standard 1459, Second Edition\*

CONTENTS	PAGE
Part 1. GENERAL .....	2
Part 2. APPLICATION GUIDELINES .....	2
Part 3. INSPECTION .....	2
Part 4. MOUNTING .....	3
Part 5. INSTALLER CONNECTIONS .....	5
Part 6. TECHNICAL ASSISTANCE .....	7
Part 7. WARRANTY & CUSTOMER SERVICE .....	8
Part 8. SPECIFICATIONS .....	9

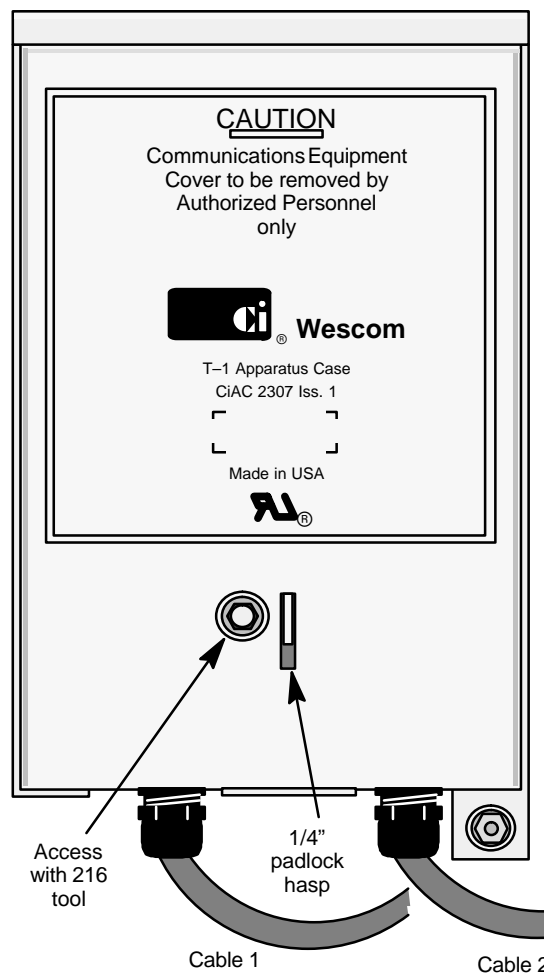

Figure 1. Front View, AC 2307

## 1. GENERAL

### 1.1 Document Purpose

This practice provides general and installation information for the Charles Industries AC 2307 Seven-Slot T1 Apparatus Case, shown in Figure 1.

### 1.2 Document Status

This document is reprinted to provide a general editorial update.

### 1.3 Equipment Function

The AC 2307 provides mounting for up to seven mini-T1 span line repeaters. The AC 2307 accommodates either 238-type or 239-type protected repeaters.

### 1.4 Equipment Location/Mounting

The AC 2307 Apparatus Case is designed for indoor mounting at or near the customer's premises, and as depicted in Figure 1, is equipped with two factory prewired cable stubs.

#### **\*CAUTION**

<p><b>Field repairs/modifications may void compliance with UL 1459 – Second Edition. Compliance with UL 1459 – Second Edition is restricted to inside plant wiring.</b></p>
---

### 1.5 Equipment Features

The AC 2307 provides the following features and benefits:

- Economical
- Simple, fast installation
- Termination of 1 to 7 span lines
- Accommodates all industry-standard 238- and 239-type T1 span line repeaters
- Factory prewired with 5-foot cable stubs (additional stub lengths available)
- Order wire standard
- Aluminum housing (backplate and cover)
- Unit access using a standard 216 tool (can wrench)
- Security from unauthorized access with optional 1/4" padlock hasp
- Complies with Underwriters Laboratories Standard 1459, Second Edition

## 2. APPLICATION GUIDELINES

The AC 2307 can be used to provision DS1 service offerings where cable losses dictate the need for a regenerator at or near the customer's premises.

For customer premises applications, the AC 2307 should be equipped with 238-type (nonprotected) or 239-type (protected) repeaters. In addition, building entrance primary protection **MUST** be provided per local practice.

## 3. INSPECTION

Inspect the equipment thoroughly upon delivery. If the equipment has been damaged in transit, immediately report the extent of damage to the transportation company.

Wescom equipment is identified by a model and issue number imprinted on the front panel or located elsewhere on the equipment. Each time a major engineering design change is made on the equipment, the issue number is advanced by one number on any subsequent models that are manufactured. Therefore, be sure to include both the model number and its issue number when making inquiries about the equipment.

#### 4. MOUNTING

The AC 2307 is typically mounted directly on a wall or wood backboard at the customer's location. Provide a suitable mounting location with adequate clearance on the left side of the unit to accommodate the unit's inside swing-out chassis (module mounting housing).

The AC 2307 is equipped with a hasp on the front panel which can accept a padlock, with up to a 1/4" shackle, to provide added security. See Figure 1 and Figure 2.

Step	Action
1.	<p><b>Remove the cover of unit:</b></p> <p>Using a standard 216 tool, turn the hex nut in the cup washer a minimum 3 turns (approximately 90°) counterclockwise as shown in Figure 2.</p> <p>Grasp the bottom of the cover and pull out and up as shown in Figure 2.</p>
2.	Rotate the module-housing to the left, as shown in Figure 3.
3.	Using the key-slot mounting hole on the backplate of the AC 2307 (see Figure 3) as a template, mark the mounting location for the unit, leaving adequate clearance on the unit's left side.
4.	Install a proper size fastener (screw or other suitable hardware) at the marked location. Leave a sufficient length of the fastener extending from the mounting surface to hang the unit.
5.	Hang the unit on the fastener, and when properly oriented, secure the unit to mounting location by tightening the fastener. Further secure the unit by installing a fastener in each of the two dimpled mounting holes.
6.	<p><b>If installer connections are not to be performed at this time, replace the cover:</b></p> <p>Slide the top of the cover down over the top lip of the unit's backplate, centering the cover over the backplate.</p> <p>Press the cover bottom down until it snaps into place over the cable brackets at the bottom of the unit's backplate (cover should conceal both cable brackets).</p> <p>Secure unit access by turning front hex nut clockwise until tight.</p>

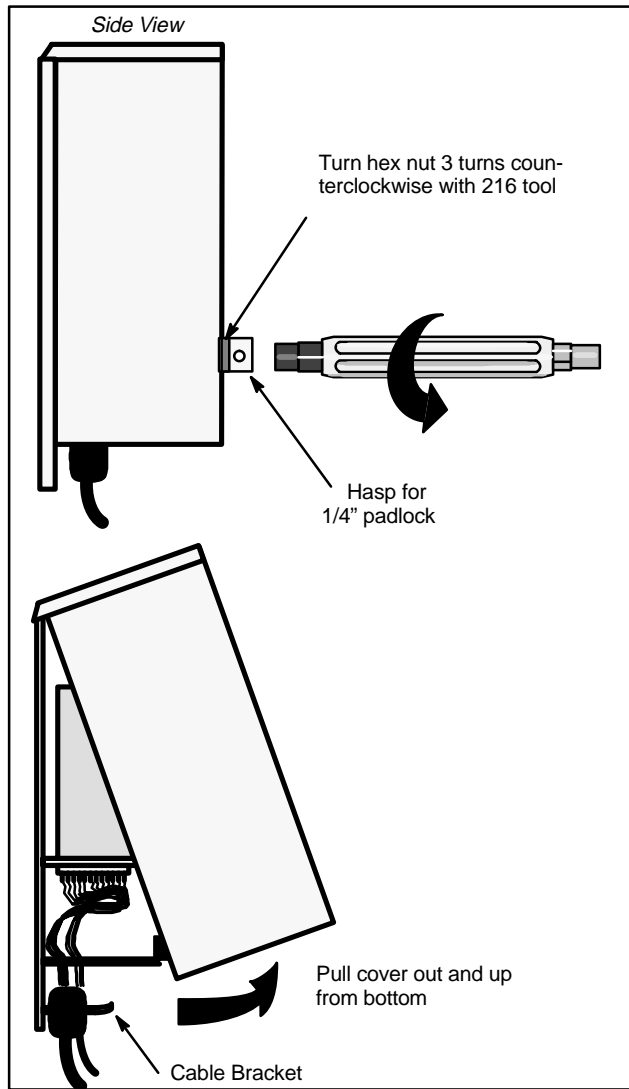

Figure 2. Removing Front Cover

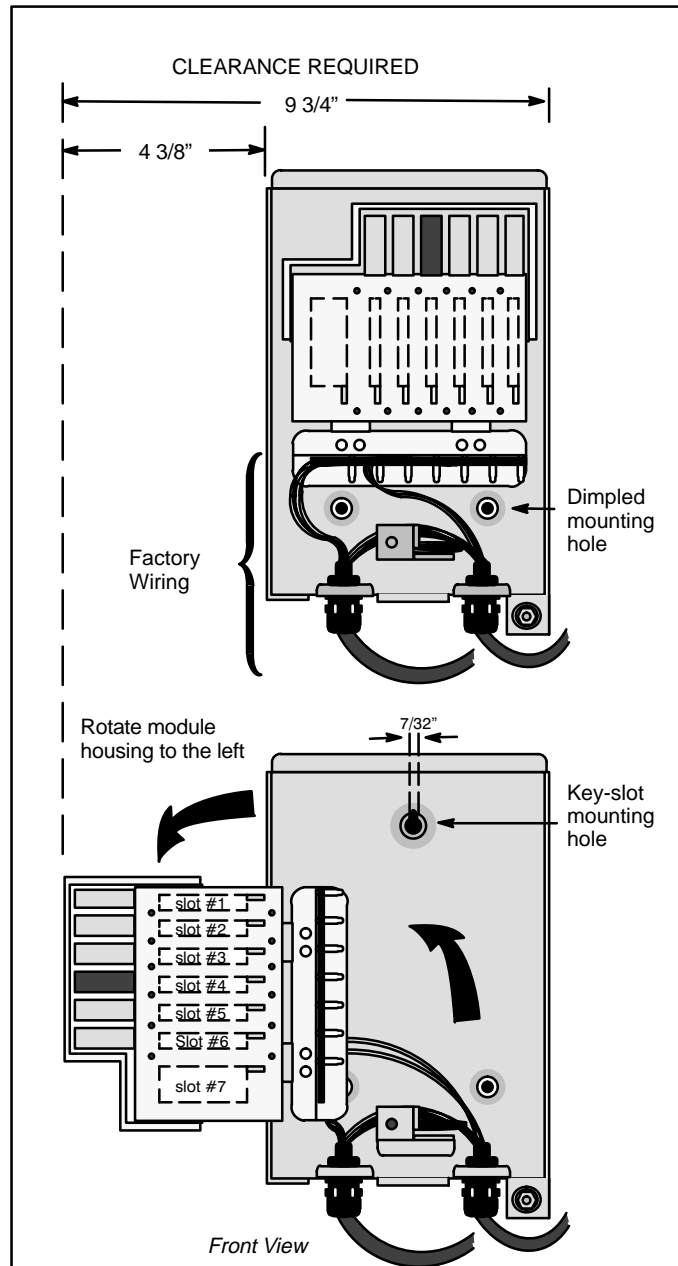

Figure 3. Required Clearance For Rotating Module-Housing (Cover Removed)

## 5. INSTALLER CONNECTIONS

All signal lead connections to the AC 2307 are made via the cable stubs which are factory prewired to the mounting assembly. Each stub consists of sixteen pairs of 22-gauge cable and a foil wrap shield. The cable shields are connected to chassis-ground internally in the mounting assembly. They should not be connected to ground elsewhere.

The splicing diagram of a AC 2307 equipped with bidirectional (two-way) repeaters is shown in Figure 4.

For off-customer premises applications, the AC 2307 should be equipped with CiSA-4 Surge Arrestors. Rotate the module-mounting housing to the left, as shown in Figure 3, to expose the module connector pins. Install a CiSA-4 Surge Arrestor assembly over each set of pins as shown in 5.

**Section AC2-307-001**

The AC 2307 provides screw terminal at the bottom of the case for connection to earth ground (refer to Figure 6). The terminal is equipped with a 1/4" stud nut and washer and should be connected to an earth ground with a 14-gauge (minimum) wire.

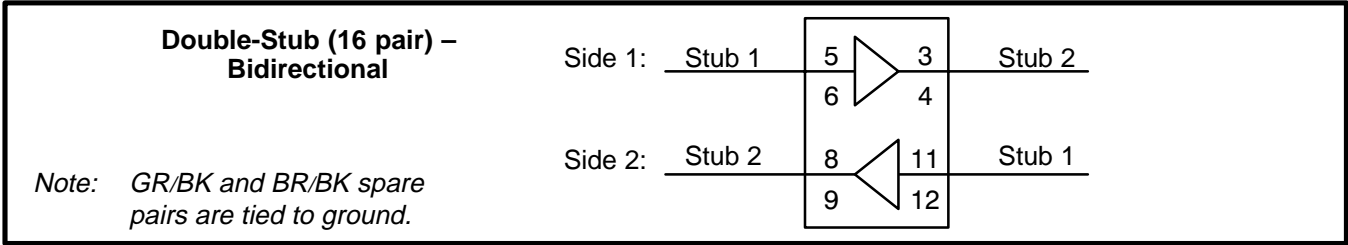

Slot	Stub 1 In Pairs				Stub 2 Out Pairs			
	Side 1		Side 2		Side 1		Side 2	
	Pin 6	Pin 5	Pin 12	Pin 11	Pin 4	Pin 3	Pin 9	Pin 8
1	BL	WH	GR	RD	BL	WH	GR	RD
2	OR	WH	BR	RD	OR	WH	BR	RD
3	GR	WH	SL	RD	GR	WH	SL	RD
4	BR	WH	BL	RD	BR	WH	BL	RD
5	SL	WH	OR	BK	SL	WH	OR	BK
6	BL	RD	GR	BK	BL	RD	GR	BK
7	OR	RD	BR	BK	OR	RD	BR	BK
<b>Fault Locate</b>	<b>Pin 5</b>		<b>Pin 3</b>		<b>Pin 5</b>		<b>Pin 3</b>	
	SL		BK		SL		BK	
<b>Order Wire</b>	<b>Red Post</b>		<b>Green Post</b>		<b>Red Post</b>		<b>Green Post</b>	
	BL		YEL		BL		YEL	

**Figure 4. Splicing Diagram for 7-slot Inside Mount AC 2307**

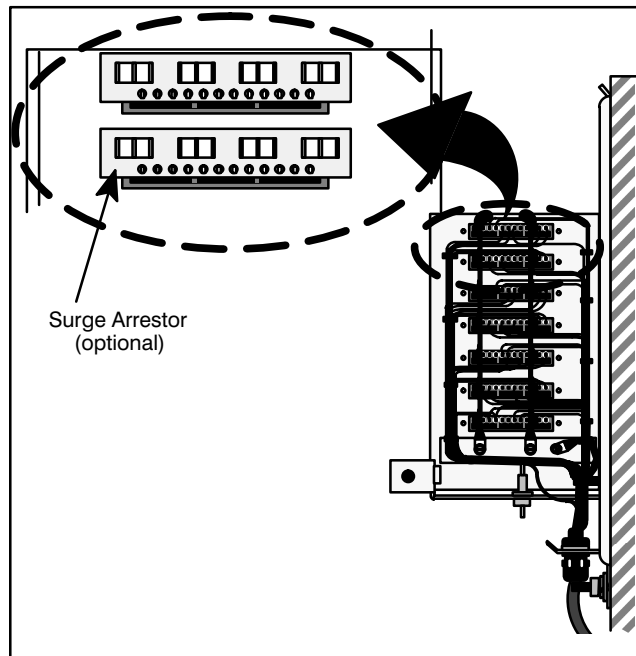

**Figure 5. Optional CiSA-4 Surge Arrester Assembly Installed Over Pins**

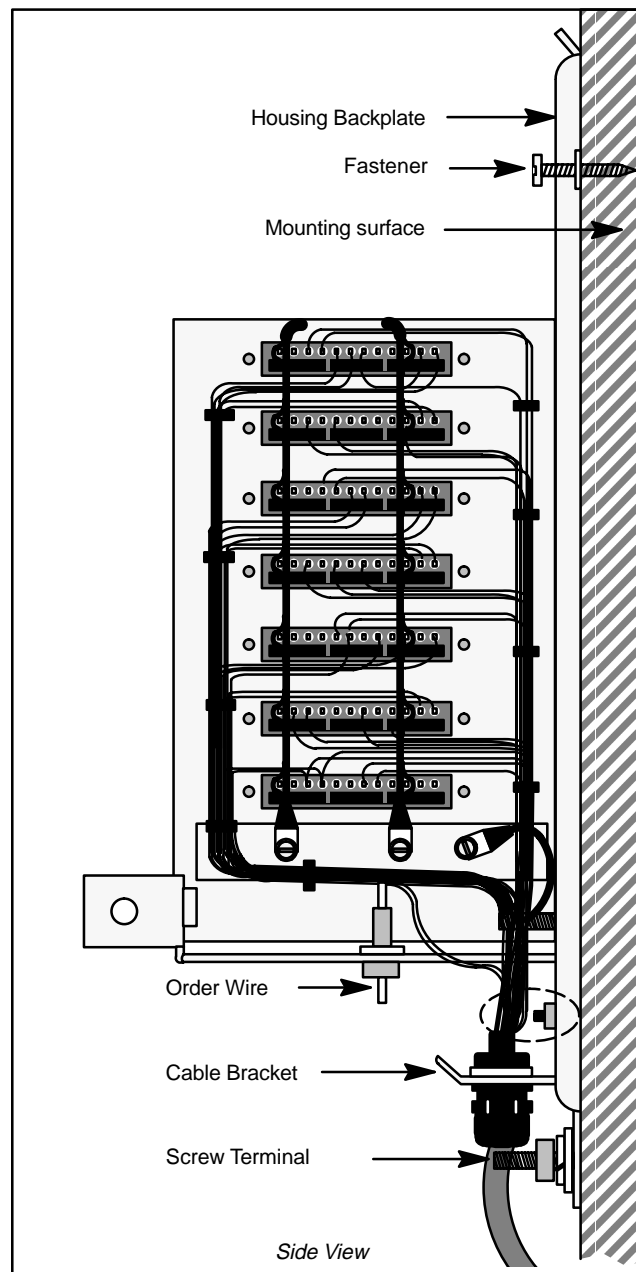

Figure 6. Rotated Module Housing Exposing Module Connector Pins And Wiring

## 6. TECHNICAL ASSISTANCE

### 6.1 Technical Assistance — U.S.

If technical assistance is required, contact Charles Industries' Technical Services Center at:

847-806-8500

847-806-8556 (FAX)

800-607-8500

techserv@charlesindustries.com (e-mail)

### 6.2 Technical Assistance — Canada

Canadian customers contact:

905-821-7673 (Main Office)  
905-821-3280 (FAX)

## **7. WARRANTY & CUSTOMER SERVICE**

### **7.1 Warranty**

Charles Industries, Ltd. offers an industry-leading, 5-year warranty on products manufactured by Charles Industries. Contact your local Sales Representative at the address or telephone numbers below for warranty details. The warranty provisions are subject to change without notice. The terms and conditions applicable to any specific sale of product shall be defined in the resulting sales contract.

Charles Industries, Ltd.  
5600 Apollo Drive  
Rolling Meadows, Illinois 60008-4049

Telephone:                   847-806-6300 (Main Office)  
                                  847-806-6231 (FAX)

### **7.2 Field Repairs (In-Warranty Units)**

Field repairs involving the replacement of components within a unit are not recommended and may void the warranty and compatibility with any applicable regulatory or agency requirements. If a unit needs repair, contact Charles Industries, Ltd. for replacement or repair instructions, or follow the *Repair Service Procedure* below.

### **7.3 Advanced Replacement Service (In-Warranty Units)**

Charles Industries, Ltd. offers an "advanced replacement" service if a replacement unit is required as soon as possible. With this service, the unit will be shipped in the fastest manner consistent with the urgency of the situation. In most cases, there are no charges for in-warranty repairs, except for the transportation charges of the unit and for a testing and handling charge for units returned with no trouble found. Upon receipt of the advanced replacement unit, return the out-of-service unit in the carton in which the replacement was shipped, using the pre-addressed shipping label provided. Call your customer service representative at the telephone number above for more details.

### **7.4 Standard Repair and Replacement Service (Both In-Warranty and Out-Of-Warranty Units)**

Charles Industries, Ltd. offers a standard repair or exchange service for units either in- or out-of-warranty. With this service, units may be shipped to Charles Industries for either repair and quality testing or exchanged for a replacement unit, as determined by Charles Industries. Follow the *Repair Service Procedure* below to return units and to secure a repair or replacement. A handling charge applies for equipment returned with no trouble found. To obtain more details of this service and a schedule of prices, contact the CI Service Center at 217-932-5288 (FAX 217-932-2943).

#### *Repair Service Procedure*

1. Prepare, complete, and enclose a purchase order in the box with the equipment to be returned.
2. Include the following information:
  - Company name and address
  - Contact name and phone number
  - Inventory of equipment being shipped
  - Particulars as to the nature of the failure
  - Return shipping address
3. Ship the equipment, purchase order, and above-listed information, transportation prepaid, to the service center address shown below.



CI Service Center  
Route 40 East  
Casey, IL 62420–2054

4. Most repaired or replaced units will be returned within 30 or 45 days, depending on the product type and availability of repair parts. Repaired units are warranted for either 90 days from the date of repair or for the remaining unexpired portion of the original warranty, whichever is longer.

## 8. SPECIFICATIONS

See Table 1 for the physical characteristics of the AC 2307.

**Table 1. Physical Specifications**

<b>Feature</b>	<b>U.S.</b>	<b>Metric</b>
Height	11.27 inches	28.63 cm
Width	7.23 inches	18.36 cm
Depth	4.42 inches	11.23 cm
Weight (without cable stubs)	3.00 lbs.	1.36 kg
Cable Stub Length	5 feet* nominal	1.52 m
<b>Operating Environment</b>		
Temperature	0° to 50°C (32 to 122°F)	
Humidity	0–95% (no condensation)	

*Note: Other stub lengths are available.*

