

# DC Surge Suppressor

## INSTALLATION INSTRUCTIONS

Models 93-SS12

93-SS24

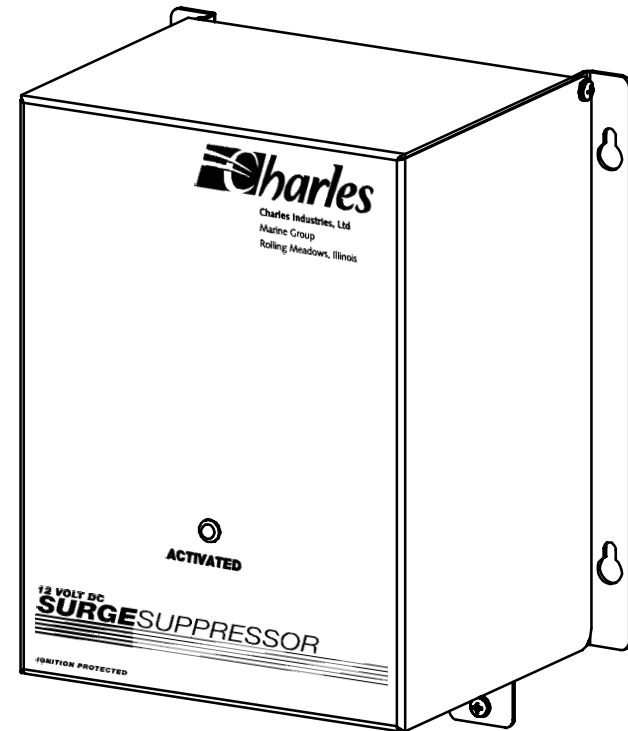
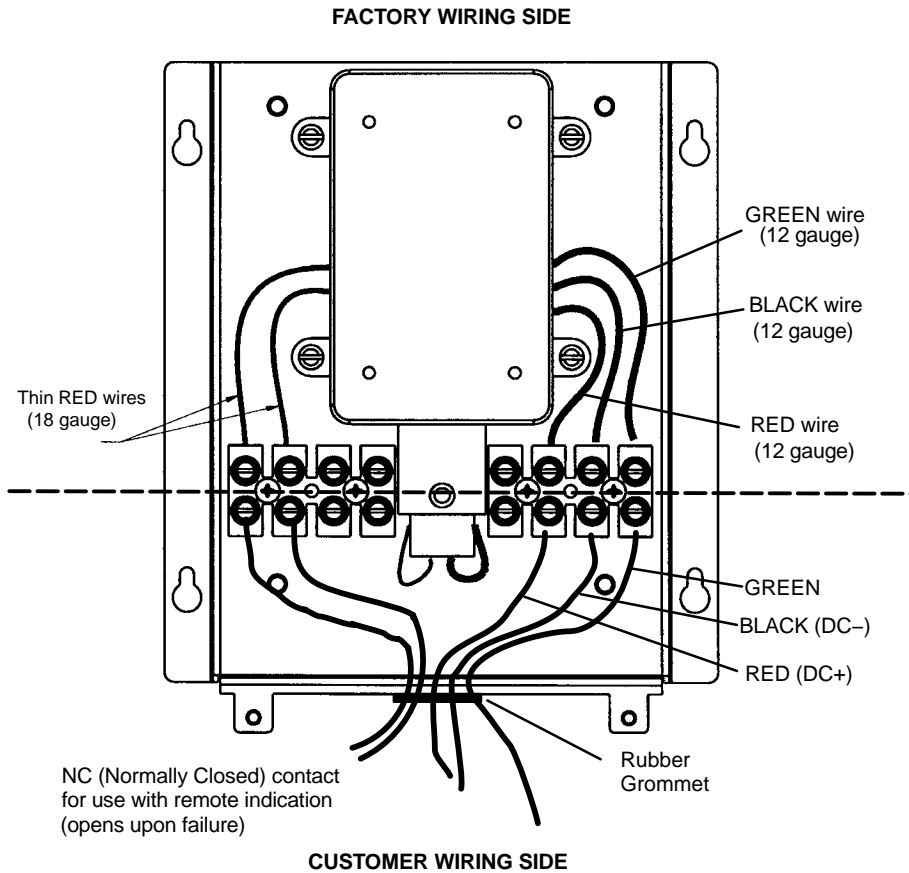

Figure 1.



**INTRODUCING... THE 12- & 24-VOLT DC SURGE SUPPRESSORS**

Thank you for purchasing the DC Surge Suppressor. Your surge suppressor is designed to provide protection from surges, spikes, or lightning through the battery banks.

**MOUNTING THE SURGE SUPPRESSOR**

The surge suppressor may be mounted on any surface as close as possible to the wiring. Choose a location that allows the most direct connection to the phase conductors and neutral-ground busses. This unit is intended to be mounted inside the boat, in an area protected from excessive moisture and strong sunlight.

**Choosing Mounting Hardware**

As with any marine equipment, secure mounting is of utmost importance. The bolts or screws used to secure the unit must be #8 or #10, backed with a flat washer, and kept vibration-free with a lock washer. Take the mounting surface into consideration when choosing the length of the bolts or screws used. All hardware should be corrosion-resistant.

Step	Action
1.	Hold the suppressor vertically flush on the mounting surface.
2.	Mark the mounting holes and remove the unit.
3.	Drill the mounting holes.
4.	Insert one side of the mounting hardware half-way into the drilled mounting holes.
5.	Align the mounting slots on the unit with the secured hardware and slide the unit's mounting flange under the washers.
6.	Insert the mounting hardware for the other side.
7.	Secure all mounting hardware.

**WIRING THE SUPPRESSOR**

Cut all wires as short as possible and strip wires about 1/4 inch before making connections. Avoid unnecessary loops and bends in the wire.

**WARNING**

**DANGEROUS POWER LEVELS MAY EXIST ON DC LINES! Prior to wiring, disconnect power to the boat and connections or fuses to the batteries.**

Step	Action
1.	Using a Phillips screwdriver, remove the 2 screws at the bottom of the housing and open the cover.
2.	Remove the rubber grommet. Cut it open, and run conductor and ground wires through it.
3.	Connect the conductor and ground wires to the screw terminals as shown in Figure 1.
4.	<b>If you are using a remote status indicator</b> , connect the remote status wires to the screw terminals as shown in Figure 1.
5.	Replace the grommet in its slot. Close and screw down the cover, and connect the power.

**LED STATUS INDICATORS**

See the following table for LED status.

Label/Color	Status	Indicates...
ACTIVATED/ Green	ON	Normal operation; surge suppressor active.
	OFF	Suppressor not powered. Check boat power. Unit failure. See <i>Warranty and Customer Service</i>

**WARRANTY & CUSTOMER SERVICE**

The CHARLES Marine & Industrial Group warrants the unit will be free from defects in materials and workmanship that cause mechanical failure for two (2) years, as set forth in the Limited Warranty. Notice of any alleged defect in material or workmanship must be provided within thirty (30) days of discovering the problem, and within the warranty period. Follow the procedure outlined below to obtain warranty service.

**Service Center and Repair Correspondence**

*Note: Do not attempt to service the unit. Contact the Service Center.*

To contact the Service Center via telephone directly:

800-830-6523 (Toll Free)

217-932-2317 (Voice)

217-932-2473 (FAX)

Call to obtain a Returned Materials Authorization (RMA) number prior to returning any unit to Charles Industries.

Return the unit for repairs to the Service & Repair Center address below:

Charles Industries, Ltd.

Marine & Industrial Group

503 NE 15th Street

Casey, IL 62420-2054

USA

Correspondence can be sent to Corporate Headquarters via the address below:

*Note: Do not return the unit to this address.*

Charles Industries, Ltd.

Marine & Industrial Group

5600 Apollo Drive

Rolling Meadows, IL 60008-4049

847-806-6300

www.charlesindustries.com