3.6 KVA IsoG2™
SHORELINE ISOLATION TRANSFORMER

**INSTALLATION INSTRUCTIONS
& OWNER'S MANUAL
Model 93-ISOG26-A**

Contents

INTRODUCING... THE 3.6 KVA IsoG2™	3
Manual Purpose	3
APPLICATION	3
IMPORTANT SAFETY INSTRUCTIONS	3
Warnings	3
Installation Precaution	4
Environmental Precaution	4
Application Precaution	4
Damaged Unit Precaution	4
Disassembly Precaution	4
INSTALLING THE IsoG2™	5
Ratings and Connections	5
Choosing an Electrical Wiring Method	5
Wired as an Isolation Transformer	5
Choosing Mounting Location	8
Choosing Mounting Hardware	8
Mounting the IsoG2	8
Horizontal Mount	8
Vertical Mount	8
Choosing the Appropriate Wire Type and Gauge	9
Choosing Electrical Wiring Hardware	9
Overcurrent Protection	9
Making IsoG2 Connections	9
Securing Covers	11
Applying Power	11
OPERATING THE IsoG2™	11
Safety First	11
Proper Operation	11
MAINTAINING THE IsoG2™	11
TROUBLESHOOTING	12
WARRANTY & CUSTOMER SERVICE	12
Warranty	12
Service	12
Service Center and Repair Correspondence	12
SPECIFICATIONS	12

INTRODUCING... THE 3.6 KVA IsoG2™

Thank you for purchasing the IsoG2™! Your IsoG2 completely isolates input power from output power providing an improved degree of safety and reducing galvanic current corrosion due to the direct connection to AC shore power.

Manual Purpose

With your personal safety in mind, this manual lists important safety precautions first, then covers installation, operation, maintenance, troubleshooting, warranty, and customer service information.

APPLICATION

The 3.6 KVA IsoG2 is a shoreline isolation transformer intended for boats with 30 amp/120 volt service. Properly installed, it will electrically isolate AC shore power from the boat's AC power system, reducing galvanic current corrosion due to the AC shore power connection.

The boat's electrical system and grounding conductor are not actually connected to the shoreside system when you use the 3.6 KVA IsoG2 as an isolation transformer. Power is transferred from the shoreside electrical system to the boat's electrical system by magnetic coupling. This means there is no direct electrical connection between the earth-grounded shore AC power and boat AC power systems. The shore grounding conductor is connected to a shield that is wound between the primary (shore) and secondary (boat) transformer windings. This shield assures isolation on the boat by providing a protective layer between primary and secondary windings within the transformer. In the unlikely event of a breakdown within the transformer, the shield can withstand the fault current of a properly sized shore supply circuit breaker long enough for the breaker to trip. In addition, by grounding the specified connection on the transformer's secondary side to the boat a "neutral" ground is established for the vessel's electrical system. When using the transformer, shoreline polarity is no longer a consideration and a shoreline polarity device is not necessary.

IMPORTANT SAFETY INSTRUCTIONS

SAVE THESE INSTRUCTIONS. This manual contains important safety and operating instructions for the IsoG2. Read the entire manual before usage. Also read all instructions and cautions for and on the IsoG2.

Warnings

WARNING — HIGH VOLTAGE

To avoid serious injury or death from high voltage electrical shock disconnect AC shore power before opening panel.

WARNING — FIRE HAZARD

Primary overcurrent protection and conductor sizing must be in accordance with manufacturer's installation instructions.

WARNING — SHOCK HAZARD

On board and in-water shock hazard. Transformer must be connected in accordance with manufacturer's installation instructions.

WARNING — FIRE HAZARD

Do not store equipment on or next to transformer. This unit is designed to operate hot and must have free air flow to prevent over heating or charring of adjacent material.

WARNING — ELECTRICAL SHOCK AND FIRE HAZARD

Cord grip connectors must be used to prevent wires from chafing on the metal case and causing an electrical short. See installation instructions for suitable connector types or call Charles Marine Products to order a connector kit.

Installation Precaution

Boat wiring is a complex task that can cause shock, corrosion and other hazards if not done properly by trained, experienced personnel. For more information on this subject contact the **American Boat and Yacht Council (ABYC)** or see the standards and regulations below:

**American Boat and Yacht Council
E-11 “Alternating Current (AC) Electrical Systems
on Boats”**

3069 Solomon’s Island Road
Edgewater, MD 21037
Telephone: 410.956.1050
FAX: 410.456.2737

**NFPA Standard 302.
“Pleasure and Commercial Motor Craft”**

National Fire Protection Association
1 Batterymarch Park
P.O. Box 9101
Quincy, MA 02269-9401
Telephone: 800.344.3555

Rules and Regulations for Recreational Boats

Excerpts from the United States Code (USC) and the Code of Federal Regulations (CFR) (U.S. Coast Guard Regulations) are available from the **American Boat and Yacht Council** listed above.

Note: Installation of the IsoG2 must be made in accordance with all applicable standards and regulations.

Environmental Precaution

The IsoG2 is intended for installation inside an engine room or elsewhere inside the boat. Make sure that the location will not subject the unit to rain, snow, excessive moisture, or excessive heat.

NOTICE

This device is ignition protected in accordance with U.S. Coast Guard regulations under 33 CFR 183.410.

Application Precaution

These units are intended for hard-wired, permanent, on-board applications. Use of attachments not recommended or sold by Charles Marine Products may result in risk of fire, electrical shock or personal injury.

Damaged Unit Precaution

Do not operate the IsoG2 if it has received a sharp blow, been dropped, immersed in water or otherwise damaged. See the section in this manual on *Warranty & Customer Service* for repair information.

Disassembly Precaution

Do not disassemble the IsoG2. See the sections in this manual on *Maintaining the IsoG2, Troubleshooting the IsoG2* and *Warranty & Customer Service*.

INSTALLING THE IsoG2™

Ratings and Connections

The 3.6KVA IsoG2 is designed for 120V input, 60Hz. Figure 1 contains information regarding connections.

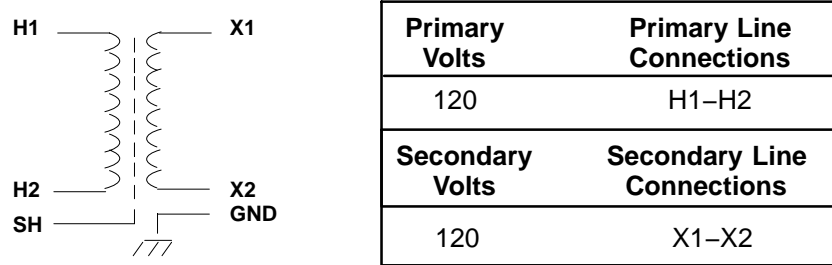

Figure 1. Schematic and Connections

Choosing an Electrical Wiring Method

There are two wiring methods that can be used to install the IsoG2 as an isolation transformer in accordance with *ABYC E-11 Alternating Current (AC) Electrical Systems on Boats*.

Note: Figure 2 and Figure 3 are reprinted with permission from the American Boat and Yacht Council (ABYC). To obtain the complete standard referenced or any other standards contact:

*American Boat and Yacht Council: 3069 Solomon's Island Road
Edgewater, MD 21037
Telephone: 410.956.1050
FAX: 410.456.2737*

Wired as an Isolation Transformer

The only difference between the two methods below is that in Method 2, a Ground Fault Protector (GFP) must be used instead of just a circuit breaker, and the shore grounding conductor is not wired past the inlet of the boat. Method 1 is most commonly used.

Note: This diagram does not illustrate a complete system. Refer to the appropriate ABYC text.

Isolation Transformer System with Single-Phase 120-Volt Input with Grounded Secondary. Shield Grounded on Shore. Metal Case Grounded on the Boat. The green grounding wire from the shore inlet is connected to the isolation transformer shield. The green grounding wire is connected to the shell of the power inlet which is insulated from the hull of the boat.

The ungrounded and grounded shore current-carrying conductors are connected from the power inlet to the primary winding of the isolation transformer through an overcurrent protection device which simultaneously opens both current-carrying shore conductors. Fuses shall not be used in lieu of the simultaneous trip devices.

120-Volt branch circuit breakers are permitted to use single-pole breakers in the ungrounded current-carrying conductors.

The secondary of the isolation transformer is grounded (polarized) on the boat.

The boat grounding system (green) conductor is connected from the metal case of the isolation transformer to all noncurrent-carrying parts of the boat's AC electrical system including the engine negative terminal or its bus without interposing switches or overcurrent protection devices.

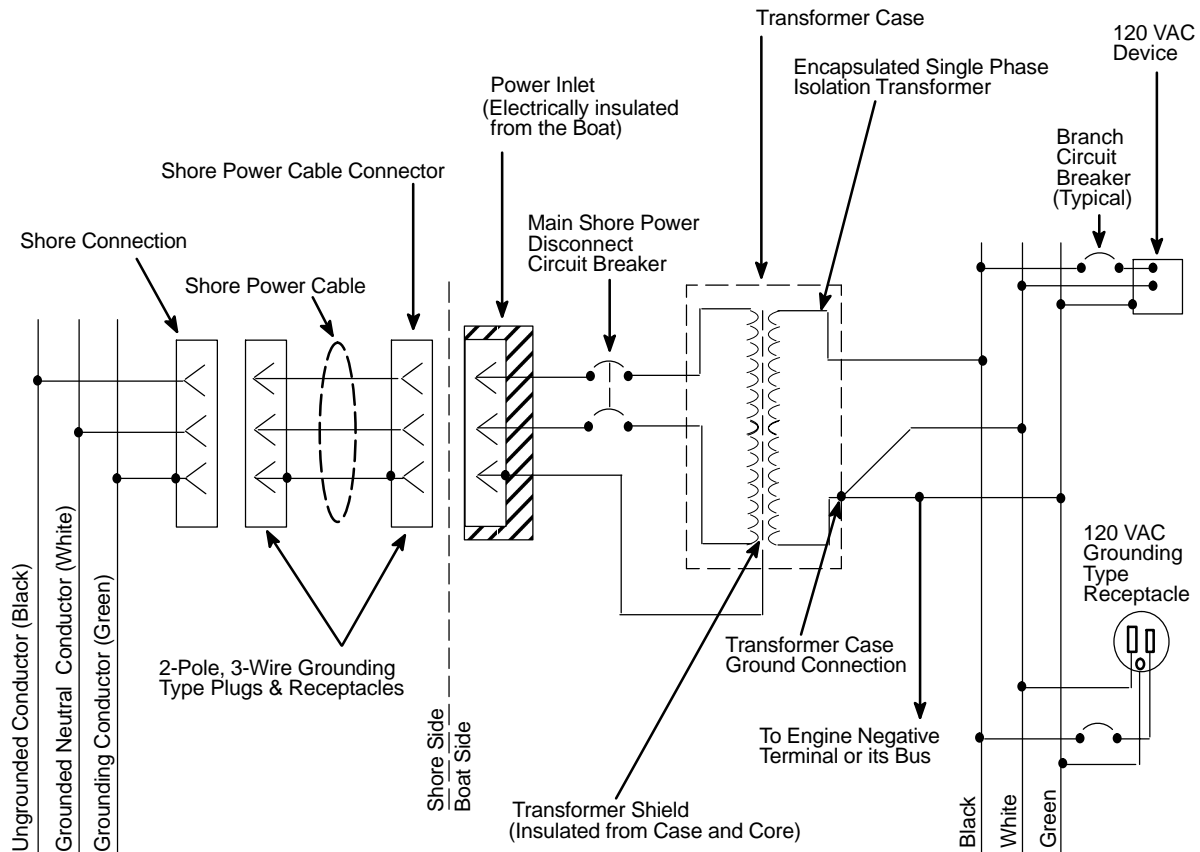

Figure 2. Electrical Diagram – Method 1 (see Figure 4 for Wiring Connections)

Note: This diagram does not illustrate a complete system. Refer to the appropriate ABYC text.

Isolation Transformer System with Single-Phase 120-Volt Input with Ground Fault Protection and Grounded Secondary. Shield and Metal Case Grounded on the Boat. The green grounding wire from the shore inlet is not connected to the isolation transformer shield or metal case. The green grounding wire is connected to the shell of the power inlet which is insulated from the hull of the boat.

The ungrounded and grounded shore current-carrying conductors are connected from the power inlet to the primary winding of the isolation transformer through a ground fault protection device which simultaneously opens both current-carrying shore conductors. Fuses shall not be used in lieu of the simultaneous trip devices.

120-Volt branch circuit breakers are permitted to use single-pole breakers in the ungrounded current-carrying conductors.

The secondary of the isolation transformer is grounded (polarized) on the boat.

The boat grounding system (green) conductor is connected from the shield and metal case of the isolation transformer to all noncurrent-carrying parts of the boat's AC electrical system including the engine negative terminal or its bus without interposing switches or overcurrent protection devices.

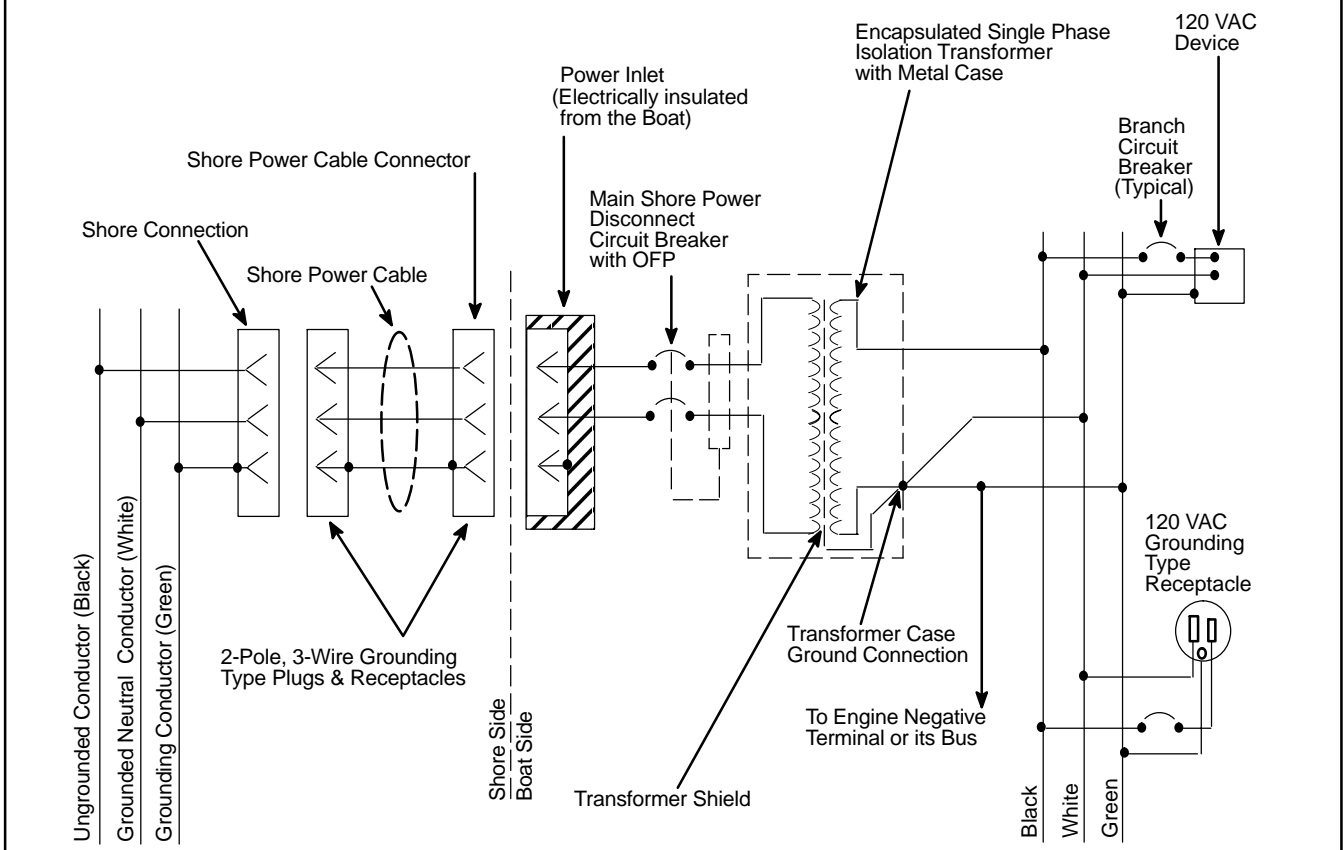

Figure 3. Electrical Diagram – Method 2 (see Figure 5 for Wiring Connections)

Choosing Mounting Location

After selecting a wiring method, the mounting location must be chosen. Like any piece of transformer operated equipment, the IsoG2 will produce a noticeable “hum” when it is energized, although not nearly as loud as non-encapsulated transformers. Consideration should be given to not mounting the IsoG2 in or immediately adjacent to areas where you will prefer it quiet, such as sleeping quarters. Locations to avoid are under bunks or on the opposite side of an uninsulated bulkhead immediately adjacent to the head of a bunk. The IsoG2 should be mounted either vertically on a bulkhead with the access panel at the bottom or horizontally on the deck in a protected area away from rain or spray. When mounted vertically the bottom must be at least 24 inches above the deck or other equipment to avoid damage from splash and to ensure adequate access to wiring connections. The unit must be mounted in a secure location capable of supporting the full weight of approximately 60 pounds. Proper ventilation around the case is important. Allow at least six inches on all four sides of the unit for air circulation and cooling. During normal operation the case of the IsoG2 may reach high temperatures. To avoid burns locate the IsoG2 in an area where persons will not come in contact with the unit.

WARNING – FIRE HAZARD

Do not store equipment on or next to transformer. This unit is designed to operate hot and must have free air flow to prevent overheating or charring of adjacent materials.

Choosing Mounting Hardware

As with any marine equipment, secure mounting is of utmost importance. You will need to provide four bolts or screws to secure the unit. They must be 1/4-inch in diameter. The screws or bolts you choose should be backed with a flat washer and kept vibration-free with a split-ring lock washer. If using bolts, they must be secured on both sides of the bulkhead and also backed with a washer or washer plate. If using screws, they should be at least 1 inch long. All hardware must be corrosion-resistant stainless steel or cadmium-plated steel.

Mounting the IsoG2

The IsoG2 may be mounted horizontally on a deck or vertically on a bulkhead.

CAUTION

Use appropriate equipment to hoist and rig unit. Care should be taken to ensure safety of individuals.

WARNING – ELECTRICAL SHOCK HAZARD

Use care when drilling to avoid contact with any wires or live components.

Horizontal Mount

Step	Action
1.	Carefully lower and position the IsoG2 on the deck in the exact location the unit will be installed. <i>Note: The wiring enclosure should be visible and accessible.</i>
2.	Remove the IsoG2 and drill four marked holes with the proper-sized drill bit.
3.	Realign the IsoG2’s mounting holes with the drilled holes and fasten the unit to the deck with the appropriate mounting hardware.
4.	Firmly secure all mounting hardware.

Vertical Mount

Step	Action
1.	Carefully lower and position the IsoG2 on the bulkhead in the exact location the unit will be installed <i>Note: The wiring compartment should be at the bottom to ensure proper cooling of the unit.</i>
2.	Remove the IsoG2 and drill four marked holes with the proper-sized drill bit
3.	Realign the IsoG2’s mounting holes with the drilled holes and fasten the unit to the bulkhead with the appropriate mounting hardware
4.	Firmly secure all mounting hardware.

Choosing the Appropriate Wire Type and Gauge

All input and output conductors should be at least 10 AWG, stranded, 600 volt rating, UL type AWM, UL 1426 or equivalent, or a UL listed marine shore power cable. See ABYC standard E-11 for more details on conductor types and sizing (gauge).

Note: Use UL Recognized ring or captive spade terminals for making all connections to the terminal block regardless of the wiring method chosen.

Choosing Electrical Wiring Hardware

The usual application for the IsoG2 is as an isolation transformer. In this application, there is no fault current path for the wiring from the shore power inlet to the IsoG2 input connections. For this reason, the wiring should only be done with a jacketed cable (.030 inches jacket thickness minimum) such as UL type 1426 boat cable or by using a UL listed marine cable set wire (type SO or equivalent). This wiring should be installed in the boat in a protected area and routed to avoid contact with sharp edges or hot surfaces.

WARNING – ELECTRICAL SHOCK HAZARD AND FIRE HAZARD

Cord grip connectors must be used to prevent wires from chafing on the metal case and causing an electrical short. See installation instructions for suitable connector types or call Charles Marine Products to order a connector kit.

The IsoG2 is intended for hard-wiring in a permanent location. Cord grip connectors with water sealing bushings and strain relief are required to secure wires or cables going into or out of the IsoG2.

Charles Marine Products recommends the cord grip connector kit listed in Table 1.

Table 1. Recommended Cord Grip Connector and Accessories

Description	Part Number	Cord Type	Manufacturer	Catalog Number	Sealing Washer	Locknut
Cord Range .660-.780	97-001127-A	6/4 Boat Cable or 6/3 Cordset	Thomas & Betts	2675	5263	142

Various other cord grip connectors may be suitable for use with the IsoG2. Contact Charles Marine Products customer service for information.

Overcurrent Protection

Overcurrent protection must be provided at the time of installation by a circuit breaker on the primary (shore) supply circuit. A two-pole shore power main circuit breaker is required for the shore power line going into the IsoG2. This should be rated at 30 amps, 120 volts, 3000 ampere interrupting capacity (AIC) and be of the long-time delay type.

A ground fault protector (GFP) is necessary if a shore grounding conductor is not used. This should be rated at 20 milli-amperes or less and if combined with the primary (shoreline) two-pole circuit breaker, should be rated at 30 amps, 120 volts, 3000 AIC and be of the long-time delay type.

Making IsoG2 Connections

WARNING – HIGH VOLTAGE

To avoid serious injury or death from high voltage electrical shock disconnect AC shore power before opening panel.

The wiring installation will depend on the method chosen in the section titled *Choosing an Electrical Wiring Method*. Follow the procedure below to make the appropriate connections.

Step	Action
1.	Remove the access cover
2.	Install the cord grip connectors using the sealing gaskets and locknuts
3.	Undo the chucks from the cord grip connectors

4.	Slide the cord grip connectors down and over the cables from the primary (shore power) circuit breaker and to the secondary (boat) circuits
5.	Insert the cables through the cord grip connectors and cut to length
6.	Strip back the insulation
7.	Use UL Recognized ring or captive spade terminals for making all connections
8.	Connect all wiring as shown in Figure 4 or Figure 5 based on the chosen wiring method
9.	Tighten all nut/bolt combinations
10.	Tighten the cord grip connectors
11.	Reinstall the access cover.

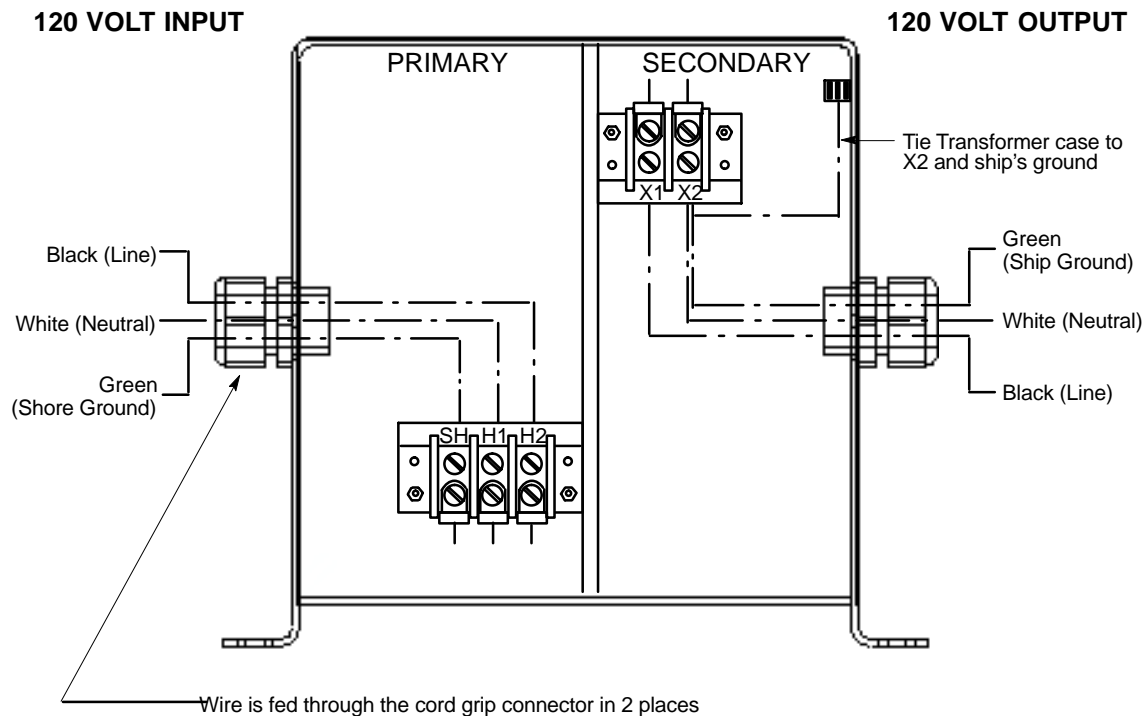

Figure 4. Terminal Placement – Method 1 (See Figure 2 for Electrical Diagram)

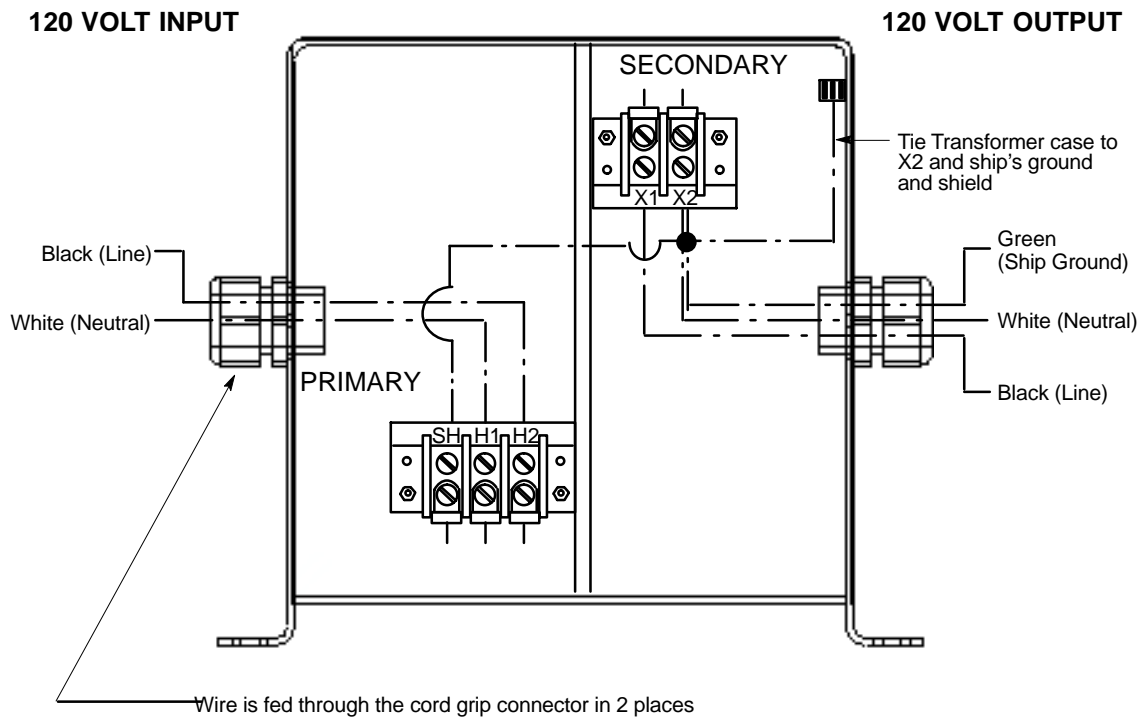

Figure 5. Terminal Placement – Method 2 (See Figure 3 for Electrical Diagram)

Securing Covers

After all connections and terminations have been made, the access cover should be re-installed using all hardware supplied.

Applying Power

Power should only be applied after all connections and terminations have been made and the access cover is secure. Plug in the shore power and turn on the appropriate circuit breakers to apply power. Refer to the section on *Proper Operation*.

OPERATING THE IsoG2™

Safety First

Follow all precautions in the *IMPORTANT SAFETY INSTRUCTIONS* section in this manual. Pay close attention to the DANGER, WARNING and CAUTION boxes both within this manual and labeled on the unit.

Proper Operation

When properly installed and connected, the IsoG2 will provide isolation between shore and boat power while maintaining a one to one turns ratio (shore voltage equals boat voltage).

MAINTAINING THE IsoG2™

WARNING – HIGH VOLTAGE

To avoid serious injury or death from high voltage electrical shock, disconnect the AC shore power before attempting any maintenance or cleaning.

No adjustment or maintenance is required for the IsoG2 other than periodic cleaning of the outside cabinet with a dry cloth and inspecting all connections for tightness and corrosion by a qualified service person.

TROUBLESHOOTING

If there is a problem with the IsoG2, first check that all connections are accurate and secure, and retest. If all connections are good, contact Charles Marine Products for technical assistance.

WARRANTY AND CUSTOMER SERVICE

Warranty

The CHARLES Marine & Industrial Group warrants the unit will be free from defects in materials and workmanship that cause mechanical failure for one (1) year, as set forth in the Limited Warranty. Notice of any alleged defect in material or workmanship must be provided within thirty (30) days of discovering the problem, and within the warranty period. Follow the procedure outlined below to obtain warranty service.

Service

Note: Do not attempt to service the unit. Contact the Service Center.

Service Center and Repair Correspondence

To contact the Service Center via telephone directly:

800-830-6523 (Toll Free)

217-932-2317 (Voice)

217-932-2473 (FAX)

Call to obtain a Returned Materials Authorization (RMA) number prior to returning any unit to Charles Industries.

Return the unit for repairs to the Service & Repair Center address below:

Charles Industries, Ltd.
Marine & Industrial Group
503 NE 15th Street
Casey, IL 62420-2054
USA

Correspondence can be sent to Corporate Headquarters via the address below:

Note: Do not return the unit to this address.

Charles Industries, Ltd.
Marine & Industrial Group
5600 Apollo Drive
Rolling Meadows, IL 60008-4049
USA
847-806-6300
www.charlesindustries.com

SPECIFICATIONS

The specifications for the IsoG2 are listed in Table 2.

Table 2. IsoG2 Specifications

Feature	Specification
Input Voltage	120 VAC
Input Current	30 Amps
Output Voltage	120 VAC
Output Current	30 Amps
KVA Continuous	3.6 KVA
Operating Frequency	60 Hertz
° F/°C Rise Insulation System 220A	248° F/120° C
Insulation Class	H
% Impedance	3.4
Operating Temperature	32° F to 122° F/0° C to 50° C
Approximate Weight	60 pounds/27 kilograms
Height	8.25 inches/21.0 centimeters
Width	11.25 inches/28.6 centimeters
Width (excluding the mounting flange)	8.25 inches/21.0 centimeters
Depth	9.25 inches/23.6 centimeters

