

Charles Fiber Sealed Drop Closure

FSDC-H Series

General Description and Installation

1. GENERAL INTRODUCTION	1
1.1 Document Purpose.....	1
1.2 Product Purpose.....	1
1.3 Product Mounting and Location.....	1
2. PRODUCT DESCRIPTION	1
3. SAFETY PRECAUTIONS	2
4. INSTALLATION	3
4.1 Route Express Cable Loop into Closure.....	3
4.2 Route and Splice Fiber Inside Closure.....	5
4.3 Closing the FSDC.....	7
4.4 Connecting Hardened Drops.....	8
4.5 Mounting the Closure.....	9
5. TECHNICAL ASSISTANCE AND REPAIR SERVICE	11
6. MODEL NUMBER INFORMATION	11

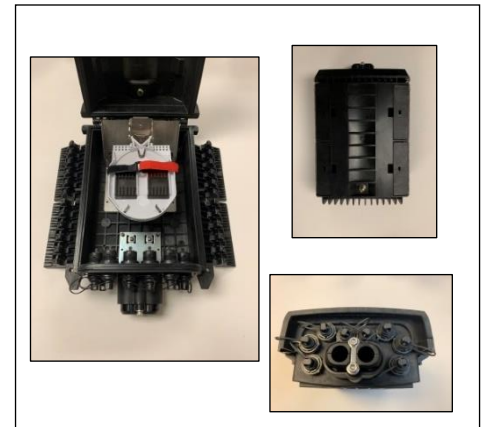

Figure 1 FSDC-H

1. GENERAL INTRODUCTION

1.1 Document Purpose

This document provides installation instructions for the Charles Fiber Sealed Drop Closure for hardened connectorized assemblies (FSDC-H). A typical FSDC-H is shown in Figure 1.

-NOTE-

Hereafter the Charles Fiber Sealed Drop Closure Series will be referred to as the "FSDC-H" or "closure."

1.2 Product Purpose

The FSDC-H is a sealed splice closure (IP68 rated) used in fiber splicing applications where a single feed fiber must be split into multiple drop connections.

1.3 Product Mounting and Location

The FSDC-H can be aerial strand mounted, pole mounted, or wall mounted. Mounting brackets are sold separately. The FSDC-H is a sealed unit that can also be used in a hand-hole or in a pedestal.

2. PRODUCT DESCRIPTION

The FSDC-H is a closure that allows splicing operations between feed and drop fibers. Some models include splicing trays, and with others the trays are purchased separately (Table 1). The tray can be equipped with an optical tap or a fiber splitter, which allows a single feed signal to be split into multiple drop signals.

The FSDC-H is designed for quick plug-and-play subscriber additions. The units have eight hardened Amphenol-H connectors to SC/APC adapters on the front face. These connectors accept OptiTap[®] and OptiTap compatible hardened connector assemblies.

The FSDC-H dimensions are shown in Figure 2. The FSDC-H ships with a number of tools and accessories, shown in Figure 3.

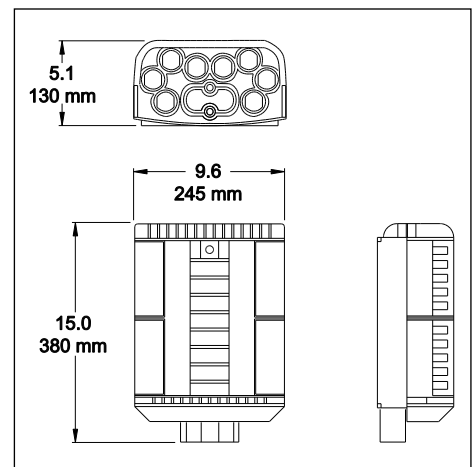

Figure 2 FSDC-H Dimensions

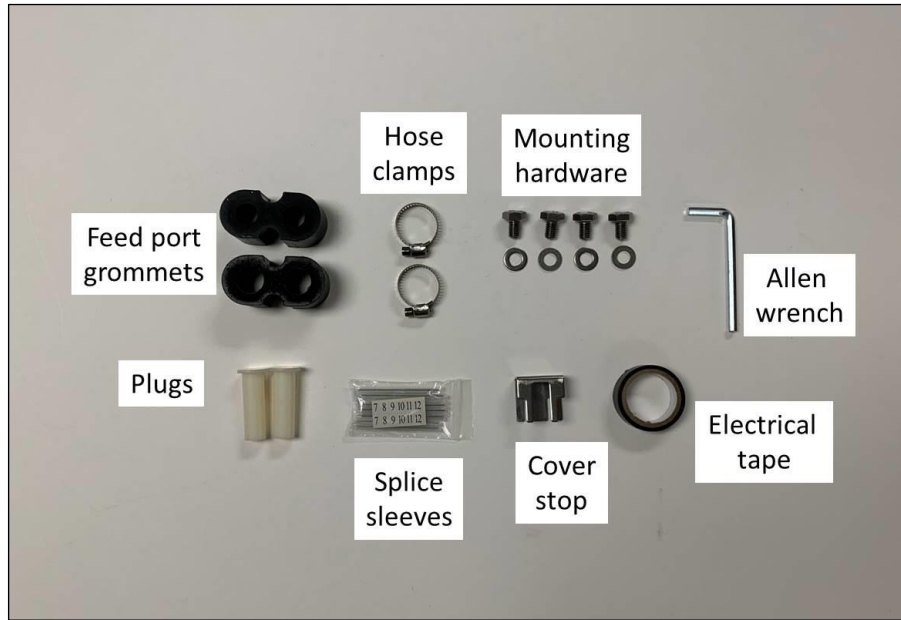

Figure 3 Tools and Accessories

3. SAFETY PRECAUTIONS



— WARNING —

Risk of serious eye damage! Never look into the end of a fiber optic line or use a magnifier in the presence of laser light or radiation. Exercise caution when installing, testing or maintaining live circuits. If eyes are exposed to laser light or radiation occurs, immediately seek treatment by a medical professional.



— WARNING —

Cable and fiber cleaning solvents may contain hazardous or harmful materials. Maintain good housekeeping practices and refer to the MSDS when working with cleaning solvents or similar products.

Shards and cleaved glass fibers are very sharp and can easily pierce the skin. Use tweezers to pick up cut glass fibers and place them in a specifically designated container. Do not consume any food products near the cable installation site.

Corrugated metal or armor in feed cables is very sharp when cut or exposed. Exercise extreme caution to prevent personal injury. Use protective work gloves when handling armored cable.



— CAUTION —

Perform all bonding and grounding prior to making any electrical and communications connections.

Be careful not to damage any buried cables or service wires while digging either to expose cables or to prepare a hole or trench, or while driving stakes. Buffer tubes and fibers are sensitive to excessive bending, pulling, and crushing forces. To avoid kinking of buffer tubes and fiber damage or breakage, exercise great care when working with fiber, and do not exceed or violate minimum bend radius requirements for fibers, buffer tubes, and cables.

4. INSTALLATION

Gather the following equipment to perform the FSDC-H installation.

- Philips and flathead screwdrivers
- 5 mm (or 3/16") Allen wrench
- Measuring tape
- Cable marking tool
- Assorted cable ties
- Accessories kit (provided with the FSDC-H)
- Knife or snips (to cut grommets)
- Buffer tube stripper tool (score/cut buffer tubes)
- Fiber optic stripper tool
- Fiber splicing tools and equipment
- Safety glasses and work gloves

4.1 Route Express Cable Loop into Closure

Step Number	Instruction	
1	<p>Use the included Allen wrench or any 5mm or 3/16 Allen wrench to loosen the two security screws near the bottom corners of the FSDC-H. Use a flathead screwdriver to pry open the four hinged latches that hold the FSDC-H closed.</p> <p>Note: The accessory bag includes a closure cover stop, which can be placed in the door hinge to hold the door securely open.</p>	
2	<p>Locate the express port (oval port) on the bottom of the FSDC. Use a 5 mm (or 3/16") Allen wrench to remove the sealing components.</p> <p>Note: The express port can accommodate cable with OD from 10 to 17.5 mm (0.394 to 0.689 inches).</p> <p>Select the proper size rubber gasket from the accessory kit based on the fiber cable diameter. Use the smaller rubber gasket for cables 10 to 12mm outer diameter and the larger rubber gasket for cables 12.5 to 17.5mm.</p>	<div style="text-align: center; margin-top: 10px;"> <p>Express Port Sealing Components</p> </div>
3	<p>Slit the rubber middle gasket apart on the outsides.</p> <p>Separate the pieces of the plastic inner gasket.</p> <p>Set these gaskets aside for later use.</p>	

<p>4</p>	<p>Remove and set aside the screws from the plastic outer gasket.</p> <p>Remove and set aside the metal compression plate that seals the express loop plug in the port.</p> <p>Disassemble and set aside the plastic outer gasket and set the components aside.</p>	
<p>5</p>	<p>Locate the attachment plate in the FSDC-H closure.</p> <p>There are two brackets for securing a strength member and two slots for attaching a hose clamp.</p>	
<p>6</p>	<p>Obtain a cable and remove the sheath from a 6.5 to 7.0 foot (max. 7.0 ft.) section. Cut the strength member to a 2.5 to 3.0" length on both sides of the unsheathed section.</p> <p>Discard sheathing and scrap strength member according to local practice.</p> <p>Push and feed a 6.5 to 7.0 foot (max. 7.0 ft.) length of unsheathed cable into the express loop-through hole.</p>	
<p>7</p>	<p>Guide the strength members on each side of the cable loop under the clamps, using a Philips screwdriver to tighten the clamps in place.</p> <p>Use a 6 mm hose clamp on each cable to secure in place (clamps included in the accessory bag).</p>	
<p>8</p>	<p>Take the previously removed plastic inner gasket and connect the pieces around the sheathed cables. Push this grommet inward into the express loop port.</p> <p>Fit the rubber middle gasket around the cables. Push this gasket inward into the express loop port.</p>	
<p>9</p>	<p>Reassemble the previously removed plastic outer gasket around the cables.</p> <p>Put the previously removed metal compression plate back in place and retrieve the express port screws. Use the 5 mm (or 3/16") Allen wrench to secure the express port sealing components together in the express loop port.</p>	

4.2 Route and Splice Fiber Inside Closure

The FSDC-H can accommodate a number of fiber architectures including splitters, optical taps, or fanout/pigtails.

Charles offers splitter trays and optical tap trays. Splitters are available in 1x2, 1x4, or 1x8 configurations and come in 4" x 6" Charles splice trays. Alternatively, if preferred, the user may install a loose PLC splitter into a Charles splice tray. Select splitters with SC/APC connector output. Charles optical tap trays are only available in the longer 4" x 9" splice tray. If using the 4" x 9" splice tray, it must be installed in the top position on the hinged bracket.

When a splitter is installed in the FSDC, route a single buffer tube into the tray. Select a single fiber from this buffer tube to splice to the splitter or tap input (white) fiber. Generally, this input fiber enters the tray on the left side. Use a connectorized splitter to connect the output legs of the splitter or the drop legs of the tap by plugging the connector into the SC adapter side of the hardened adapters inside the closure.

These closures can also be used with direct connection fanout or pigtail kits. The fanout or pigtail kits are not included and must be ordered separately.

<p>1</p>	<p>The FSDC-H can accept either:</p> <ul style="list-style-type: none"> • One long (4"x9") splice tray in the top position and one short (4"x6") splice tray in the bottom position OR • Two short (4"x6") splice trays. <p>Attach trays to the hinge bracket. If using a long tray (second image), then it must be attached at the top position on the hinge.</p>	
<p>2</p>	<p>Route buffer tube in the basket underneath the trays. Buffer tubes must pass under the hinge bracket to avoid kinking. Tie down as needed using cable ties to ensure that no buffer tubes will get pinched in the door hinge when the FSDC-H is closed.</p>	
<p>3</p>	<p>Mark the point where the buffer tube will enter and exit the tray using a permanent marker. Strip the buffer tube sheathing between these two points to expose the fibers. Secure the buffer tube at its entry and exit points using customer supplied felt and cable ties. Ensure that the cable ties are positioned over the ends of the buffer tube sheathing, not over bare fibers.</p>	

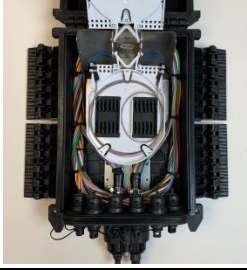
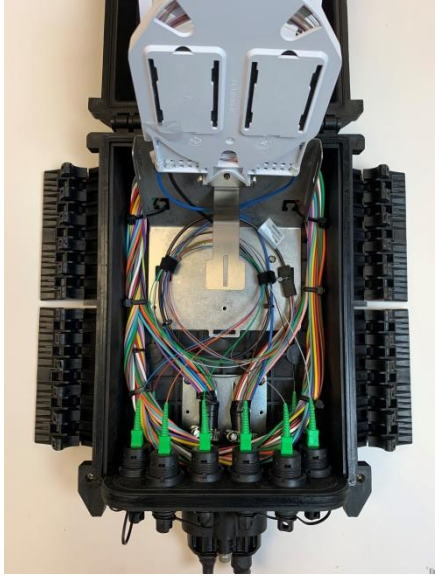
<p>4</p>	<p>Coil and route fibers inside the tray.</p>	
<p>5</p>	<p>Locate the connectorized fanouts that come with the FSDC. Plug the connectors into the ports on the inside of the FSDC-H and coil the fanout fibers in the basket beneath the trays. Use cable ties and Velcro strips to groom, contain, and secure the fibers as needed. Route fanout fibers into the tray. Perform splicing operations between the feed fiber and the fanout in the tray.</p>	

4.3 Closing the FSDC

When securing the four hinged latches on the cover, it is important to use care to avoid pinching the installer's fingers or skin.



USE CAUTION WHEN CLOSING THE HINGED LATCHES.

1. To close the latch, place the palm of one hand on the outside of the latch, ensuring that the palm is entirely clear of the inside of the latch. Place the other hand on the opposite side of the unit to stabilize the unit. Ensure that the hand is entirely clear of the interior side (Figure 4).
2. Push the latch toward the center of the FSDC-H until the latch snaps into place (Figure 5).
3. When all latches are closed, use an Allen wrench to tighten the security screws in the lower right and left corners of the FSDC. This tightens the latches to ensure a proper seal (Figure 6).

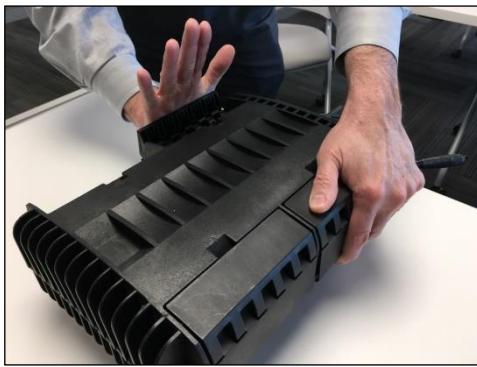

Figure 4 Closing the Hinged Latch



Figure 5 Latch After Closing

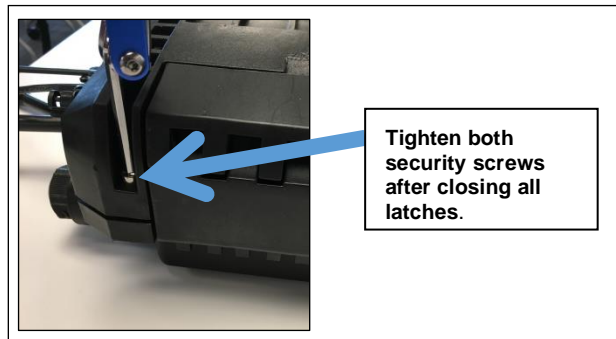

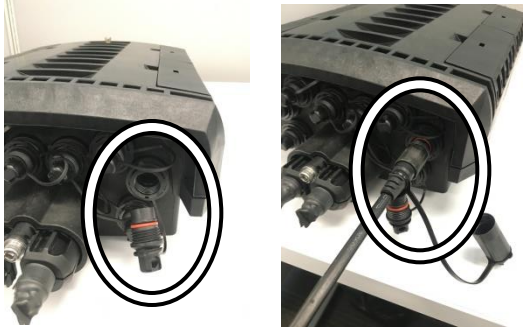



Figure 6 Tighten Screws

4.4 Connecting Hardened Drops

Step	Instruction	
1	<p>The FSDC-H can accommodate up to eight hardened OptiTap®, Amphenol H-connector, or other OptiTap compatible connector assemblies.</p> <p>Locate these eight connectors on the cable entry side of the unit.</p>	
2	<p>Unscrew the adapter cover, insert the hardened connector, and screw it on finger tight.</p>	
3	<p>After connecting, screw together the adapter cover to the connector cover to keep the covers clean.</p>	

4.5 Mounting the Closure

The FSDC-H has four threaded inserts on the back for attaching mounting hardware for either aerial strand, wall, or pole mounting (Figure 7). Hardware for attaching mounting brackets is included in the Accessory kit. See Table 1 for a listing of all mounting kits.

4.5.1 Aerial Mounting

The FSDC-H can be mounted on an aerial strand using the mounting kit 97-FSDCAMKT, which includes two mounting brackets.

1. Attach the mounting brackets using the included mounting bolts on the back of the FSDC-H (Figure 8).
2. Loosen the screws on the brackets so that the clamps can be opened and hung over the strand.
3. Tighten the clamps around the strand to suspend the FSDC-H (Figure 9). The clamps can accommodate strands of 1/4" to 3/8" diameter.

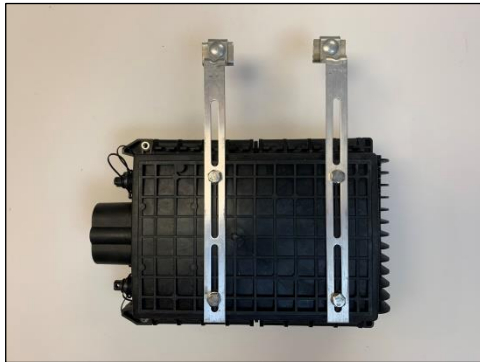

Figure 8 FSDC-H with Strand Mounting Brackets



Figure 9
FSDC-H Aerial Strand Mounting

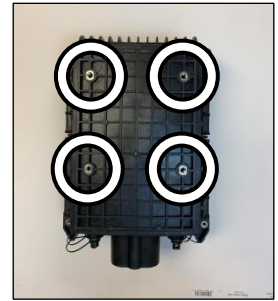

Figure 7
Mounting Inserts for
Bracket Hardware

4.5.2 Pole Mounting with Straps

To mount the FSDC-H on a pole with straps, order the pole mounting kit 97-FSDCPLKTA, which includes two mounting brackets and two mounting straps.

1. Attach the pole mounting brackets using the included mounting bolts on the back of the FSDC-H (Figure 10).
2. Open and route the two mounting bands through the brackets and around the pole.
3. Close and tighten the straps (Figure 11).



Figure 10 Pole Mounting Brackets



Figure 11 Pole Mounted FSDC

4.5.3 Pole Mounting with Lag Bolts

To mount the FSDC-H on a pole with lag bolts, order the pole mounting kit 97-FSDCPLKTB, which includes two mounting brackets.

1. Attach the pole mounting brackets using the included mounting bolts on the back of the FSDC (Figure 12).
2. Position the FSDC-H where it will be mounted and mark the lag bolt positions on the pole for drilling.
3. Drill holes for lag bolts.
4. Use customer supplied hardware to secure the FSDC-H to the pole.

4.5.4 Wall Mounting

The FSDC-H can be wall mounted using the pole mounting bracket kits. To mount horizontally, use kit 97-FSDCPLKTA (Figure 13). To mount vertically, use kit 97-FSDCPLKTB (Figure 14).

The installer must supply corrosion resistant expansion screws or anchors appropriate for the wall type (e.g., concrete, brick, wood).

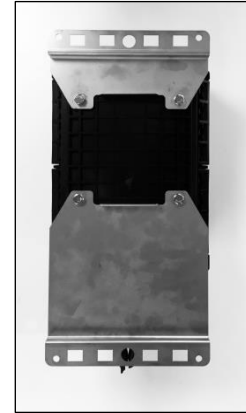

Figure 12
Brackets for Pole Mounting

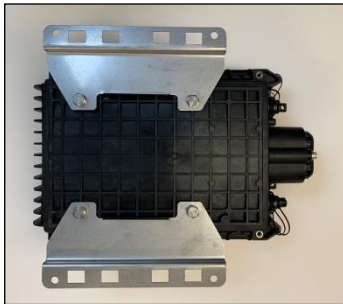

Figure 13
Brackets for Horizontal Mounting



Figure 14
Brackets for Vertical Mounting

5. TECHNICAL ASSISTANCE AND REPAIR SERVICE

For questions on product repair or if technical assistance is required, contact Charles Technical Support.

847-806-8500

techserv@charlesindustries.com (email)

<http://www.charlesindustries.com/techserv.htm>

6. MODEL NUMBER INFORMATION

Model	Description
FSDCBT08HSCV	Fiber Sealed Drop Closure, 8 hardened H-connector (OptiTap compatible) to SC/APC adapters, air pressure valve (no trays included)
FSDCBS08HSCV	Fiber Sealed Drop Closure, 8 hardened H-connector (OptiTap compatible) to SC/APC adapters, one 4"x 6" 24 splice tray, air pressure valve
FSDC2S08HSCV	Fiber Sealed Drop Closure, 8 hardened OptiTap compatible to SC/APC adapters, two 4"x 6" 24 splice trays, air pressure valve
Optional Equipment	
97-FSDCAMKT	Aerial strand mount brackets
97-FSDCPLKTA	Pole mount kit with pole bands
97-FSDCPLKTB	Pole mount kit for lag bolts
97-FSDCLTRAY	FSDC-H L 12-fiber splice tray and cover kit
97-FIBR24HTRAY	4" x 9" inch Charles 12/24 fiber splice tray kit
97-SMHTRAY	4" x 6" inch Charles 12/24 fiber splice tray kit
97-SCA08LF3M	8 fiber fanout kit: SC APC loose tube 22" breakout, single-mode bend insensitive fiber, 900µm color-coded buffer, 3 m
PS-SABFM03-9A8	8 fiber pigtail kit, SM bend-insensitive fiber, simplex, 900 µm color-coded buffer, 3 m
CFST-S11020A	1 x 2 PLC splitter tray with 900 µm input fiber and SC/APC 900 µm 22" output pigtails in 4"x6" hinged tray
CFST-S11040A	1 x 4 PLC splitter tray with 900 µm input fiber and SC/APC 900 µm 22" output pigtails in 4"x6" hinged tray
CFST-S11080A	1 x 8 PLC splitter tray with 900 µm input fiber and SC/APC 900 µm 22" output pigtails in 4"x6" hinged tray

Table 1 Model Numbers