

Universal Backhaul Remote Terminal

The Ideal Remote Terminal Solution for Copper/Fiber Backhaul

Charles Industries' Universal Backhaul Remote Terminal (UB-RT) brings a new level of compactness to a full-featured Optical Remote Terminal. Its small size and light weight allows technicians to install these terminals in virtually any location quickly and easily.

Designed to house a variety of manufacturers' electronic equipment, the UB-RT is pre-wired to meet your power, protection and physical interface requirements. Many customizable options give you the flexibility to meet your every backhaul application.



*UB-RT DC Power Version
(shown with optional fiber management
and heat exchanger)*



*UB-RT AC Power Version
(shown with optional fiber management
and battery backup)*

Features

- Fully integrated pre-wired remote outdoor terminal for deployment of customer specific electronics
- Three sizes:
 - 34"x26"x9" for up to 4RU electronics
 - 42"x26"x13" for up to 4RU electronics and battery backup
 - 34"x24"x20" for up to 12RU electronics
- Configurations for mixed services (DS1, DS3, Ethernet, etc.)
- Supports wall or H-Frame mounting
- Low profile and light weight, allows for easy installation
- Solar shield and optional AC & DC heat exchangers for better heat management
- Optional battery backup provides up to 8 hours reserve power
- Pre-wired protector blocks
- Padlockable 3-point door latch
- Advanced hybrid T1 lightning protectors (gas tube plus solid state semiconductor)
- Pre-stubbed power cable

Configurable Options

- Pre-wired cable harnesses for various electronics
- Surge protection
- Fiber splice trays
- Protector block interface type (screw, punchdown, etc.)
- AC, DC or AC with battery backup power
- Heat Exchanger

Applications

- Backhaul
 - Wireless
 - Microwave Radio
 - Ethernet First Mile (EFM) and xDSL
- Enclosure consolidation
- Remote equipment deployments
- Adjunct to preexisting, space-exhausted cabinet installations

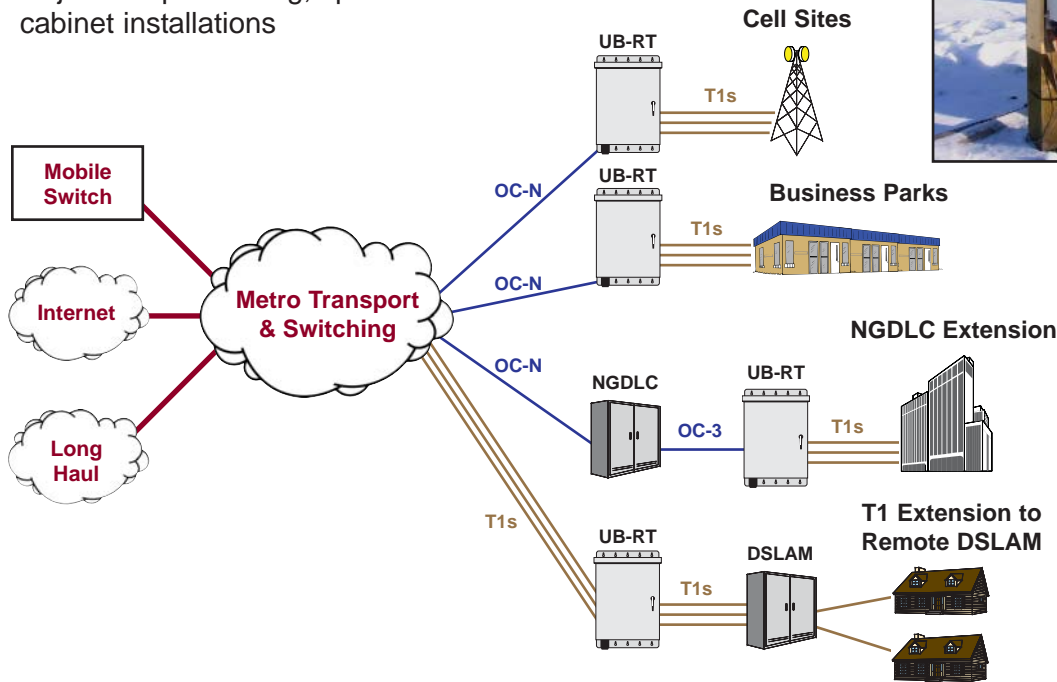

Supportable Features by Cabinet Size

| | UB-RT 33.3" x 25.6" x 9" | UB-RT 42" x 25.6" x 12.6" | UB-RT 33.4" x 23.6" x 19.7" |
|---------------------------------|-----------------------------|------------------------------|--------------------------------|
| DC Power | ✓ | ✓ | ✓ |
| AC Power | ✓ | ✓ | ✓ |
| AC Power with Battery Backup | | ✓ | ✓ |
| Heat Exchanger | ✓ | ✓ | ✓ |
| Solar Shield | ✓ | ✓ | ✓ |
| Swing Mount Door | ✓ | ✓ | |
| Room for up to 4RU Electronics | ✓ | ✓ | |
| Room for up to 12RU Electronics | | | ✓ |
| Fiber Management | ✓ | ✓ | ✓ |



CUSTOMER SATISFACTION
CONTINUOUS IMPROVEMENT

NETWORK EDGE INNOVATIONS™

With Charles, You Can Depend On:

- Field-proven and unequalled 24-hour technical support
- Individualized application consultation
- Training courses available

Visit our website at <http://www.charlesindustries.com>

Charles Industries, Ltd.
Telecommunications Group
5600 Apollo Drive
Rolling Meadows, IL 60008

Voice: (847) 806-6300
FAX: (847) 806-6231
E-mail: mktsterv@charlesindustries.com



 is a registered trademarks of Charles Industries, Ltd.

D-AAT112-E08