

# ***CiAC A239A Sealed T1 Mini-Repeater***

---

***The A239A Sealed T1 Mini-Repeater is environmentally sealed and designed for universal use for either outside plant or customer premises environments.***

Easy to mount and connect to the network, the A239A T1 Mini-Repeater allows for faster response to service requests. The A239A T1 Mini-Repeater also features Automatic Line Build-Out (ALBO), which accommodates a wide range of receive signals (0.0 to 35dB loss).

Ideal for T1 spans to one or a small number of locations, such as a small business or school, in situations where a full apparatus case would be under-utilized and cost-prohibitive.

## ***Features***

---

- Dual regenerators for use on 1.544 Mbps two-way T1 spans
- Hardened circuits for low level surge protection
- Green LED power indicator
- Thru or Loop powered
- Fully compatible with AMI or B8ZS line coding
- High immunity to induced AC
- Transmit (XMT) and Receive (RCV) color-coded conductors
- Four foot conductor stubs; filled, shielded and bonded
- 14 AWG insulated ground lead
- 350 VDC gas tube protection (optional)
- Weather, ultraviolet (UV) and chemical resistant housing and encapsulant
- Top and bottom mounting tabs

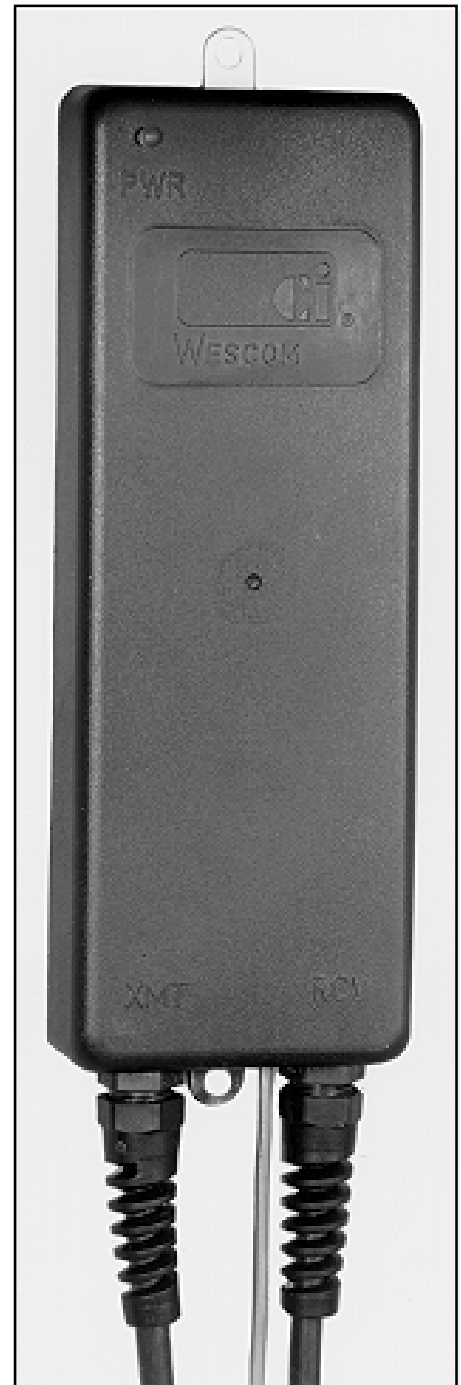

# CIAC 239A Sealed T1 Mini Repeater

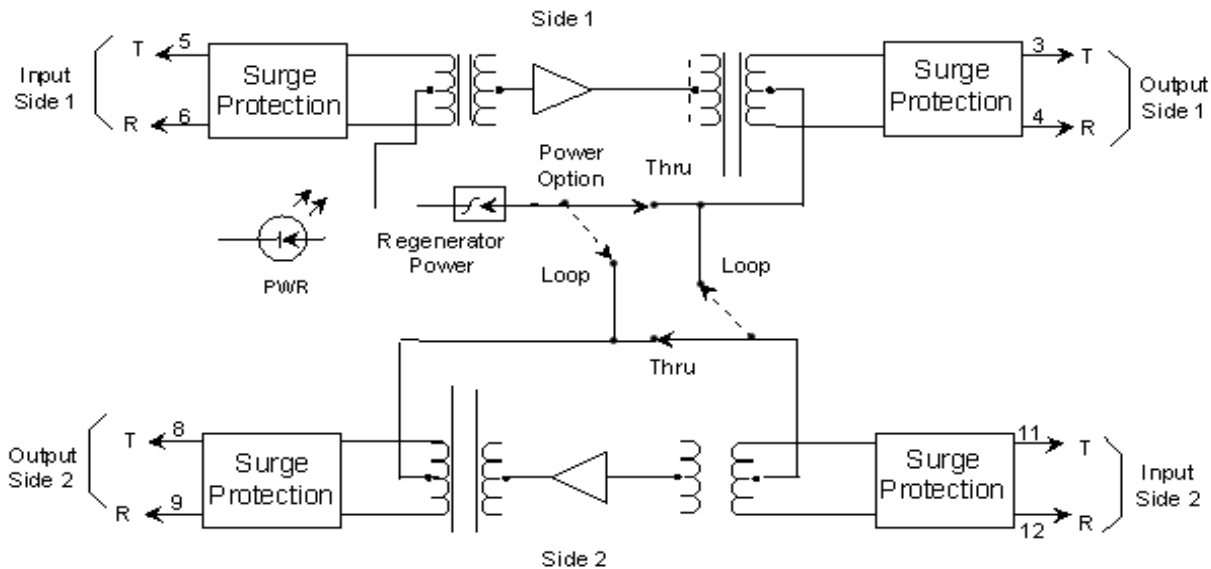

## Specifications

Length	9 in (case only), 11 7/16 in (with strain reliefs)
Width	3 5/16 in
Depth	1 1/4 in
Weight	2 lbs, 6 oz
Temperature	-40° to +170° F
Humidity	100 %
Stub Length	4 ft standard (other in 2 ft increments optional)

## Ordering Information

93-A239AXLP-A	Loop powered, surge protection
93-A239AXTP-A	Thru powered, surge protection
93-A239AXLX-A	Loop powered, no surge protection
93-A239AXTX-A	Thru powered, no surge protection
93-A239AZLP-A	Loop powered, surge protection, 35 ft. cable
93-A239AZTP-A	Thru powered, surge protection, 35 ft. cable

### **With Charles Industries, You Can Depend On:**

- Field-proven and unequaled technical support
- 24-hour Technical Support
- Training courses available

Visit our website at <http://www.charlesindustries.com>



Charles Industries, Ltd.  
Telecommunications Group  
5600 Apollo Drive  
Rolling Meadows, IL 60008

Telephone: (847) 806-6300  
FAX: (847) 806-6231  
E-Mail: [mktserv@charlesindustries.com](mailto:mktserv@charlesindustries.com)  
Website: [www.charlesindustries.com](http://www.charlesindustries.com)

 is a trademark of Charles Industries, Ltd. D-DSL006-A99